

NATIONAL REPORT ON

**THE STRESS TESTS
FOR NUCLEAR POWER PLANTS
IN SLOVAKIA**

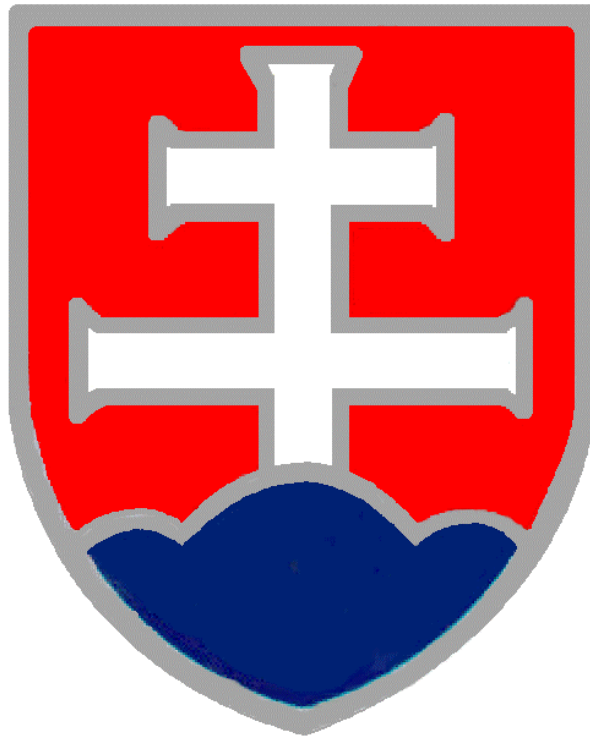

NUCLEAR REGULATORY AUTHORITY

OF THE SLOVAK REPUBLIC

30 DECEMBER 2011

Contents

EXECUTIVE SUMMARY	8
0 Introduction	22
0.1 OBJECTIVES OF THE REPORT	22
0.2 SPECIFICATION AND SCOPE OF STRESS TESTS	22
0.3 METHODOLOGY AND ORGANIZATION OF STRESS TESTS BY THE UTILITY	23
0.4 RELEVANCE OF LESSONS LEARNED FROM FUKUSHIMA ACCIDENT	24
0.5 PROCESS OF SAFETY REVIEW AND UPGRADING OF NUCLEAR UNITS IN SLOVAKIA	25
0.6 STRUCTURE OF THE REPORT	26
1 General data about the sites and nuclear power plants.....	28
1.1 BRIEF DESCRIPTION OF THE SITE CHARACTERISTICS AND UNITS	28
1.1.1 Main characteristics of the units.....	30
1.1.2 Description of the systems for conduction of main safety functions	33
1.2 SIGNIFICANT DIFFERENCES BETWEEN UNITS	67
1.3 USE OF PSA AS PART OF THE SAFETY ASSESSMENT.....	68
2 Earthquakes.....	71
2.1 DESIGN BASIS.....	71
2.1.1 Earthquake against which the plants are designed.....	71
2.1.2 Provisions to protect the plants against the design basis earthquake.....	76
2.1.3 Compliance of the plants with its current licensing basis	81
2.2 EVALUATION OF SAFETY MARGINS	81
2.2.1 Range of earthquake leading to severe fuel damage.....	81
2.2.2 Range of earthquake leading to loss of containment integrity.....	82
2.2.3 Earthquake exceeding the design basis earthquake for the plants and consequent flooding exceeding design basis flood	82
2.2.4 Measures which can be envisaged to increase robustness of the plants against earthquakes.....	82

3	Flooding.....	83
3.1	DESIGN BASIS.....	83
3.1.1	Flooding against which the plants are designed	83
3.1.2	Provisions to protect the plants against the design basis flood.....	87
3.1.3	Plants compliance with its current licensing basis	91
3.2	EVALUATION OF SAFETY MARGINS	91
3.2.1	Estimation of safety margin against flooding.....	91
3.2.2	Measures which can be envisaged to increase robustness of the plants against flooding.....	92
4	Extreme weather conditions.....	93
4.1	DESIGN BASIS.....	93
4.1.1	Reassessment of weather conditions used as design basis	93
4.2	EVALUATION OF SAFETY MARGINS	96
4.2.1	Estimation of safety margin against extreme weather conditions	96
4.2.2	Measures, which can be envisaged to increase robustness of the plants against extreme weather conditions.....	98
5	Loss of electrical power and loss of ultimate heat sink	99
5.1	LOSS OF ELECTRICAL POWER.....	99
5.1.1	Loss of off-site power	100
5.1.2	Loss of off-site power and loss of the ordinary back-up AC power source.....	100
5.1.3	Loss of off-site power and loss of the ordinary back-up AC power sources, and loss of permanently installed diverse back-up AC power sources.....	101
5.1.4	Conclusion on the adequacy of protection against loss of electrical power.....	110
5.1.5	Measures which can be envisaged to increase robustness of the plants in case of loss of electrical power	110
5.2	LOSS OF THE DECAY HEAT REMOVAL CAPABILITY/ULTIMATE HEAT SINK.....	111
5.2.1	Design provisions to prevent the loss of the primary ultimate heat sink, such as alternative inlets for sea water or systems to protect main water inlet from blocking.	111
5.2.2	Loss of the primary ultimate heat sink (e.g. loss of access to cooling water from the river, lake or sea, or loss of the main cooling tower).....	112
5.2.3	Loss of the primary ultimate heat sink and the alternate heat sink	115
5.2.4	Conclusion on the adequacy of protection against loss of ultimate heat sink.....	124

5.2.5	Measures which can be envisaged to increase robustness of the plants in case of loss of ultimate heat sink	124
5.3	LOSS OF THE PRIMARY ULTIMATE HEAT SINK, COMBINED WITH STATION BLACK OUT (SEE STRESS TESTS SPECIFICATIONS)	125
5.3.1	Time of autonomy of the site before loss of normal cooling condition of the reactor core and spent fuel pool (e.g. start of water loss from the primary circuit)	125
5.3.2	External actions foreseen to prevent fuel degradation	125
5.3.3	Measures, which can be envisaged to increase robustness of the plants in case of loss of primary ultimate heat sink, combined with station black out.....	125
6	Severe accident management.....	126
6.1	ORGANIZATION AND ARRANGEMENTS OF THE LICENSEE TO MANAGE ACCIDENTS	126
6.1.1	Organization of the licensee to manage the accident.....	129
6.1.2	Possibility to use existing equipment.....	139
6.1.3	Evaluation of factors that may impede accident management and respective contingencies	142
6.1.4	Conclusion on the adequacy of organizational issues for accident management	146
6.1.5	Measures which can be envisaged to enhance accident management capabilities.....	146
6.2	ACCIDENT MANAGEMENT MEASURES IN PLACE AT THE VARIOUS STAGES OF A SCENARIO OF LOSS OF THE CORE COOLING FUNCTION	146
6.2.1	Before occurrence of fuel damage in the reactor pressure vessel/a number of pressure tubes (including last resorts to prevent fuel damage).....	146
6.2.2	After occurrence of fuel damage in the reactor pressure vessel/a number of pressure tubes	147
6.2.3	After failure of the reactor pressure vessel/a number of pressure tubes	147
6.3	MAINTAINING THE CONTAINMENT INTEGRITY AFTER OCCURRENCE OF SIGNIFICANT FUEL DAMAGE (UP TO CORE MELTDOWN) IN THE REACTOR CORE.....	147
6.3.1	Elimination of fuel damage / meltdown in high pressure	147
6.3.2	Management of hydrogen risks inside the containment	148
6.3.3	Prevention of overpressure of the containment.....	150
6.3.4	Prevention of re-criticality	151
6.3.5	Prevention of basemat melt through.....	152
6.3.6	Need for and supply of electrical AC and DC power and compressed air to equipment used for protecting containment integrity	154
6.3.7	Measuring and control instrumentation needed for protecting containment integrity.....	155

6.3.8	Capability for severe accident management in case of simultaneous core melt/fuel damage accidents at different units on the same site	156
6.3.9	Conclusion on the adequacy of severe accident management systems for protection of containment integrity	156
6.3.10	Measures which can be envisaged to enhance capability to maintain containment integrity after occurrence of severe fuel damage	156
6.4	ACCIDENT MANAGEMENT MEASURES TO RESTRICT THE RADIOACTIVE RELEASES	156
6.4.1	Radioactive releases after loss of containment integrity	156
6.4.2	Accident management after uncovering of the top of fuel in the fuel pool	157
7	General conclusion.....	159
7.1	KEY PROVISIONS ENHANCING ROBUSTNESS (ALREADY IMPLEMENTED)	159
7.2	SAFETY ISSUES.....	163
7.3	POTENTIAL SAFETY IMPROVEMENTS AND FURTHER WORK FORECASTED	166
Appendix 1	170
Appendix 2	179

EXECUTIVE SUMMARY

Currently there are 4 VVER 440/213 nuclear units in operation in Slovakia, 2 units in Jaslovské Bohunice and another 2 in Mochovce site. In Mochovce there are also another two VVER 440/213 units with significantly upgraded design under construction. Total installed power of operated VVER 213 units is 1,940 MWe. The owner and operator (the holder of the operating permit) of all operating and constructed nuclear units in Slovakia is a stock company Slovenske elektrarne a.s. (SE a.s.).

In view of the lessons learned from 11 March 2011 Fukushima accident the owner has committed himself to perform so called stress tests on all units in operation or under construction. The task was further specified and its scope outlined in the letter of the regulatory body and several subsequent meetings between the operator and the regulator. The results of the stress tests are summarized in this national report. The content and structure of the main body of the national report is in full compliance with the ENSREG specification. Some additional information is included in the introductory chapter and in appendices to the report.

The state regulatory authority performing the state supervision upon the nuclear safety of nuclear installations is the Nuclear Regulatory Authority of the Slovak Republic (UJD SR). The state supervision over nuclear safety is performed in accordance with the Atomic Act (No. 541/2004) and subsequent set of regulations, in particular Regulation No. 430/2011 on laying down details of the requirements for nuclear safety. The whole set of legislative basis has been updated quite recently (in the period 2004-2006), in line with the progress in the development of the IAEA Safety Requirements and established WENRA Reference Levels. The legislation reasonably covers also the issues relevant for the European stress tests. In addition, a new revision of the atomic act is under development. Lessons learned from the stress tests and their peer review is going to be evaluated and the legal framework will be amended if it is necessary.

Relevant Safety Analysis Reports updated in line with the regulatory requirements and accepted by the regulatory body are available for all plants. PSA studies Level 1 and 2 are also available, demonstrating compliance with internationally established safety objectives. The latest update of the SAR for EBO3,4 was performed in 2009, for EMO1,2 in 2010. For MO3,4 units the Preliminary SAR was issued in 2008, preparation of the Preoperational SAR is currently in progress. Similarly, the latest update of PSA Level 1 and 2 was done in 2010 for EBO3,4 and in 2011 for EMO1,2. It is expected that parts of safety documentation specific for rare extreme external hazards will be further updated and extended in accordance with lessons learned from the stress tests.

In accordance with the Slovak national legislation all plants in Slovakia are subject to Periodic Safety Reviews with 10 years periodicity. The latest periodic review in EBO3,4 was completed in 2008, in EMO1,2 in 2009. Based on the results of the review the UJD SR issued operational permit for subsequent 10 years of operation. The permits are associated with approval of safety upgrading programme of the plants aimed at closer compliance of the safety level with contemporary safety standards. The programmes include also implementation of comprehensive severe accident mitigation measures.

All operating units in Slovakia have been subject of a number of international missions performing independent review of their safety level. Since 1991 there were in total about 20 IAEA missions (site review, design review, OSART, IPSART missions), 6 WANO missions, 2 RISKAUDIT missions and 1 WENRA mission.

Based on WANO recommendations during the period from April to October 2011 the non-standard tests and inspections of equipment important for coping with extreme conditions exceeding the basic design

were successfully performed on the operating units. The tests included verification of the long-term run of diesel generators, the possibility for delivery of cooling water from the bubbler-condenser to the spent fuel pool, for feedwater supply to steam generators from a mobile source, for supplying of water from cooling towers to essential service water system, connection of a back-up power supply from the hydro power plant, and others.

For determination of safety margins in nuclear units a systematic approach called Configuration Matrix Method was developed. The approach is based on verification of performance of the fundamental safety functions for occurrence of events during operation at power as well as during shutdown modes, taking into account both fuel in the reactor as well as in the spent fuel pools. The approach identifies all feasible configurations of plant systems, both safety and operational, capable of maintaining safety functions with consideration of all possible connections available according to the design as well as those that can be set-up by personnel under given conditions in available period of time. The approach verifies presence of all conditions for functioning of the systems (i.e. power supply, working medium, instrumentation, environmental conditions, accessibility by operators, availability of procedures) and assesses how eventually these systems will be disabled in their turn with increasing load induced by the external hazards. The evaluation includes consideration of the human factor, logistic and administrative provisions for staff response in case of events initiated by unlikely extreme external conditions. All relevant information was arranged in a special database containing approximately 2,500 structures, systems and components, which will remain available for future plant safety assessments. The Configuration Matrix Method was subsequently adopted by the IAEA as one of the approaches for IAEA independent reviews.

In the text below, the main results for the different areas of the assessment performed within the stress tests are summarized.

Earthquakes

There are no tectonic structures located on the territory of the Slovakia and adjacent territories that could cause extremely strong earthquakes comparable to catastrophic earthquake in Japan. Nevertheless, the seismicity is an issue which was seriously considered in design, operation and safety upgrading of the plants and covered by the stress tests. The seismic monitoring system has been implemented and is currently in use around the nuclear sites for early identification of any seismic activity potentially affecting the NPPs.

The assessment of the seismic level of the sites was developed in accordance with IAEA recommendations. It is reflecting the current state of the art and was accepted by several international missions. In subsequent safety upgrading steps, capability of all nuclear units to maintain fundamental safety functions have been strongly increased since the original design. For EBO3,4 the initial design basis with the peak ground acceleration (PGA) 0.025 g has been increased through PGA=0.25 g (upgrading performed in 1995) up to the current value PGA=0.344 g, with corresponding upgrading completed in 2008. Similarly, in Mochovce the initial site value PGA=0.06 g was increased (based on the IAEA recommendation) to 0.1 g, which was used for the plant construction. Recently using the state of the art method the site seismic level has been raised to 0.143 g. Subsequently the regulatory body has set up the value PGA=0.15 g as a design basis for construction of MO3,4 and for safety upgrading of EMO1,2 units. Since the upgrading was largely based on conservative approach considering mainly elastic behaviour of the structures, there is a margin even above the increased PGA values. Taking into account properties of materials used for individual safety system components, with increasing loads first the occurrence of plastic deformation should take place and only after exceeding the structural limit values the component damage will occur. However, such assessment is beyond the current regulatory requirements and international standards, and the margin was

not quantified yet. More refined analyses are in progress in order to define the extra margin embedded in the original conservative design assumptions. The preliminary estimates indicate that safety margins are well beyond the design values. These margins are expected to be quantified by further evaluations.

In spite of the fact that robustness of the plant against earthquakes has been significantly increased recently and it is considered adequate in accordance with the current requirements, there are additional safety upgrading measures envisaged including in particular quantification of margins of key SSCs for earthquakes beyond the design basis earthquake and development of a seismic PSA.

Flooding

Effects of surface water sources, failure of dams, underground water and extreme meteorological conditions as potential sources of flooding were thoroughly considered. Internal flooding due to rupture of pipelines following the earthquakes was considered in the assessment, too. Due to the inland location of the sites, their distance from the sources of water and the site topography and plant layout conditions, flooding of the site due to the sources of surface water from rivers or lakes can be screened out, similarly as from the ground water. Analysis of potential failures of dams on the rivers Vah and Hron has shown that the induced flooding wave can temporarily disable pumping stations which provide raw water to the plants. These events are conservatively addressed in the stress test report as long-term losses of the ultimate heat sink.

The only meaningful sources of the site flooding are extreme meteorological conditions (strong rain, snow, combination of rain and snow melting). Recently (2011) updated study of extreme meteorological conditions for the Mochovce site was used for the assessment. Flooding of the site due to extreme precipitation is very unlikely; only if extreme precipitation is conservatively combined with blockage of the sewer system and with neglecting any recovery staff actions, up to 10 cm site water level was conservatively estimated for the return period of 10,000 years.

Electrical components/systems are the most vulnerable to flooding, depending on their location/elevation in the relevant civil structures. Proper sealing of the buildings and sufficient elevation of the entrance doors provide an adequate protection against flooding. Detailed verification has demonstrated that in both Mochovce plants large margins (more than 2-times) are already available. In Bohunice, adequate temporary fixing has been implemented and the final permanent protection is in its pre-design stage. In addition, for the situations without any fixing time for flooding safety important components/systems was estimated demonstrating that the time margin to flooding of essential power supply is more than 72 hours. It is important to state that flooding due to precipitation does not occur suddenly and it is not associated with damaging hydrodynamic wave, therefore time margins exist and damaging impact is much less significant.

The measures for further improvements of the current situation include updating the procedures for prevention of the blockage of inlets to the sewer system, development of an updated meteorological study also for the Bohunice site, completion of the ongoing implementation of preventive measures against water entering into the buildings and providing additional fire brigade pumps for removal of water from the flooded area. In addition it is required that the comprehensive assessment of the extreme meteorological conditions will be performed and corresponding parts of the SARs will be updated in order to take into account new meteorological data, ongoing plant upgrading measures and state of the art methodology.

Extreme meteorological conditions (other than extreme precipitation)

Assessment performed within the stress tests included meteorological events and their combinations, such as extreme temperatures and humidity, extreme drought, ice and snow impact, extreme direct and rotating wind. Feasibility of logistics needed for the emergency preparedness was also evaluated.

Due to location of Slovakia in the mild meteorological region of Europe, extreme conditions were not considered as a major issue in the past, resulting in some cases in limited design information regarding resistance of plant systems, structures and components. Subsequently the evaluations of the effects of extreme meteorological conditions in the stress test report are mostly qualitative (in particular in EBO3,4), based on operating experience and on engineering judgment. Nevertheless, the performed assessment and operational experience has proved that the resistance of the plant against meteorological extremes is acceptable. Extreme drought does not represent serious safety issue since it is a slowly evolving process and the site water inventory is sufficient for more than 10 days of residual heat removal. In addition the upgrading measures implemented with the primary aim to increase seismic resistance contribute also to improved resistance against the wind. Since development of extreme meteorological conditions (except very strong wind) to severe loads on the plant requires certain time, the evaluations also show sufficient time margins for adoption of countermeasures in extreme conditions.

As already stated a new meteorological study has been developed for the Mochovce site and will be completed soon also for Bohunice. These new site data as well as ongoing plant upgrading measures and state of the art methodology will be taken into account in updating of the corresponding parts of the SARs also regarding extreme weather conditions (i.e. extreme wind, temperatures and humidity, snow amount, freeze and icing, and their combinations). This should include the detailed assessment of impact of extreme meteorological conditions on the vulnerability of high voltage line at the Bohunice and Mochovce sites. Among the prepared operational measures there are changes in plant operating procedures and preventive arrangements including increased frequency for plant walk-down to diesel generator stations during period of low temperatures, snowing and icing, and preventive measures at ambient temperatures below design values to maintain the functionality of the required equipment.

Loss of electrical power and loss of ultimate heat sink

Regarding the risk of loss of power supply it may be taken into account that in both sites there are 8 different options (with different vulnerability to external hazards) for providing power supply to plant home consumers (in addition to their redundancies); 5 of these options are independent on the electricity distribution grid. These various options can be activated either automatically or by plant staff within few tens of seconds up to two hours. There are back-up power sources capable to provide power supply for unlimited period of time. The same possibility is offered by connecting the NPPs to the preselected hydro plants. Internal power sources in the plant not dependent on the external grid include 3x100 % redundancy emergency DG with fuel reserves for 9-10 days. A decision on installation of an additional diverse DG dedicated to management of severe accidents has been made as a result of the conducted PSRs already before the Fukushima accident and implementation is currently in progress. In addition mobile DGs for recharging the batteries in case of a long-term SBO and loss of all other AC power sources are being procured. Capacity of batteries was demonstrated to be sufficient for 8-11 hours and further margins exist in optimization of their use and possibility of their recharging from a DG currently being purchased.

Time margins to irreversible losses vary according the operating regimes and success of individual measures. Large number of combinations were analysed and addressed in the stress test report; only some

of them are presented below. It was confirmed that there are inherent safety features of VVER 440/V213 contributing to significant time margins in case of loss of electric power and loss of ultimate heat sink, which include the large thermal inertia due to low power and comparably large amount of water both in primary and secondary system, as well as large volume of water inside the containment stored in the pressure suppression system potentially available for cooling of fuel.

Time margins in case of SBO occurring at full power, using only coolant inventory available in primary and secondary circuit is about 32 hours, using a mobile emergency source would extend the margin to more than 10 days, without any off-site assistance. For shutdown regimes this time interval is extended at least to 2.7 days, and with use of demineralised water emergency tanks up to 13 days. For loss of heat removal from the spent fuel pool, time margins without any operator actions are more than 30 hours for the most conservative case with complete off-loading of the core into the pool, or more than 150 hours for more realistic situations (for partial core unload). These margins can be further extended by about 4-14 hours using coolant from the bubbler condenser trays. Staff interventions by means of the fire trucks would resolve the issue for the unlimited period of time. Containment integrity in case of a complete loss of heat removal will be maintained (without staff actions) for at least 3-5 days.

For NPPs in Slovakia the external atmosphere serves as the primary ultimate heat sink, steam dumping to the atmosphere is an alternate mode of heat removal. Although this UHS in principle cannot be lost, the transport of heat to the UHS can be disabled. Such situations were subject to assessment within the stress tests. If normal plant cooling through the secondary circuit and cooling towers is not available, remaining options include direct release of steam from steam generators to atmosphere through the steam by-pass stations, or by primary circuit feed and bleed, or by heat removal through the essential service water system, the last one being qualified also for emergency conditions. Since failure of all essential service water systems could have serious consequences regarding heat removal from the core, from the spent fuel pool and from the containment, this case was analysed in detail in the stress tests as the most conservative one. If the loss of essential service water is not caused by the station black-out discussed above, loss of raw water supply should be considered. However, large water inventory of cooling water in each unit is sufficient for heat removal for about 8 to 16 days and on-site inventory for about a month. The case of a combined station black-out and loss of ultimate heat sink in case of VVER 440/V213 design is in fact covered by the station black-out only, since the station black-out is always connected with the loss of ultimate heat sink.

As described above, the evaluation of safety margins at station black-out proved the ability to ensure protection of safety barriers during considerably long time, thus providing sufficient time for accident management actions for recovery of the plant power supply. Despite the robustness of the current plant design, the following improvements are still being considered:

- To increase resistance and reliability of AC emergency power supply for beyond design basis accidents by installation of new 6 kV emergency DG for severe accidents,
- To provide 0.4 kV DG for each unit for charging batteries and supplying selected unit consumers during SBO including modifications of the pumps of borated coolant system enabling their use during SBO,
- To provide technical solution and cable pre-preparation in order to facilitate mechanical interconnection of batteries between systems,
- To provide lowering the need for emergency illumination in order to extend life time of batteries (subdivision into sections with the possibility for switching off unnecessary consumers, use of energy saving bulbs),

- To provide monitoring system of capacity of batteries (for EBO 3,4),
- To provide mobile measuring instruments able to use stable measuring sensors without power supply,
- To provide vital power supply for containment drainage valves and hydroaccumulator isolation valves (for EMO),
- To consider possibility to control selected valves without vital power supply by means of small portable motor 3-phase generator 0.4 kV,
- To develop operating procedure for possible use of diesel generators installed in Levice switchyard for SBO event (for EMO),
- To assure long-term serviceability of communication means for MCR operators and shift service staff,

For enhanced resistance of the plant in the case of loss of UHS the following modifications are planned:

- To provide additional mobile high-pressure source of SG feedwater for each site, and to ensure logistics of supplies for the mobile source, with possible use for both EBO and EMO (the same nozzles),
- To establish the logistic system for provision of emergency feedwater to suction of mobile emergency pumps from external pure (potable water) water sources after exhaustion of demineralized water inventory,
- To modify connection of emergency mobile source of coolant to the emergency feedwater system suction and discharge with accessibility from the ground level (in EMO) in order to ensure availability of the source in cases of internal and external floods and fires,
- To construct a fixed line for maintaining the coolant inventory in SFP from a mobile source (fire pumps),
- To consider modifications providing for removal of steam from the SFP to the reactor hall and to the atmosphere in case of coolant boiling,
- To document behaviour of the reactor coolant pump seals at long-term failure of cooling (more than 24 hours) in the UHS loss regime.

Severe accident management

Development and implementation of the accident management programme including mitigation of severe accidents has been an on-going process in all nuclear units in Slovakia independently of the Fukushima accident. Symptom-based emergency operating procedures (EOPs) addressing design basis accidents and preventive part of severe accidents were fully implemented in EBO3,4 and EMO1,2 in 1999 (for events initiated during power operation) and in 2006 (for events initiated in the reactor under shutdown or in the spent fuel pool). Plant specific severe accident management guidelines (SAMG) were prepared for EBO3,4 and EMO1,2 during the period from 2002 to 2004. In 2004-2005, an overall study defining technical specification of modifications and extensions of the VVER 213 basic design needed for implementation of SAMG was prepared. The project of implementation of modifications to support the severe accident management on the basis of SAMG was proposed in compliance with all the requirements and recommendations in Slovak legislation in 2006 - 2007. The SAM implementation project was initiated in 2009 as the common EBO3,4 and EMO1,2 project with deadline in 2013 in EBO and the follow-up implementation in EMO1,2 (implementation accelerated after the Fukushima, with the new deadline 2015).

The measures being implemented include dedicated means for the primary circuit depressurization, hydrogen management using passive autocatalytic recombiners, containment underpressure protection, in-vessel corium retention by strengthening of the reactor cavity and providing for its flooding, dedicated large external tanks with the boric acid solution with dedicated power source and pump aimed at possible

spent fuel flooding, and serving as a supplementary source of coolant for the reactor cavity flooding and for washing out the fission products from the containment atmosphere, modifications enabling coolant make-up to the reactor cavity, spent fuel pool and external source tanks using mobile source connected to the external connection point on walls of the reactor building and auxiliary building, and associated I&C needed for severe accident management. The measures are being implemented for possible use of large amount of coolant from the water trays of the bubbler condenser as an additional source of coolant. Implementation of reliable in vessel molten corium retention prevents complicated ex-vessel phenomena associated with core-concrete interaction, direct containment heating, production of non-condensable gases leading to containment overpressurization, etc.; all these phenomena are associated with large uncertainties.

Large part of the required plant modifications has been already implemented (e.g. installation of autocatalytic recombiners, measures for flooding of the reactor cavity). The long term heat removal from the containment is in the current scope of the SAM project ensured by recovery of service ability of the design basis equipment – the containment spray system.

SAM project being currently implemented in both EBO3,4 and EMO1,2 is based on originally defined scope with assumptions for occurrence of a severe accident on only one of two units. In view of the lessons learned the project completion will be followed by evaluation of a possible extension to management of a severe accident on both units at the same time. Further SAMG improvement and preparation of additional supporting documents for decision making by SAMG and main control room teams will be adopted based on results of validation at the project completion.

Regulatory approach

The available legislation provides for sufficient power and flexibility for the regulatory body to address situations like occurred following the Fukushima accident. In particular, the Atomic Act among other requires to reassess the safety level of nuclear facilities and to take adequate countermeasures after obtaining new significant information about the associated risks. The obligation to perform the relevant assessment and implement the countermeasures is put on the licence holder.

As already explained the regulatory body gradually updates the relevant Slovak nuclear safety legislation in accordance with the progress harmonized under the WENRA framework and IAEA Safety Requirements. The plants are being upgraded towards closer compliance with the new requirements within the Periodic Safety Review processes.

After Fukushima, several meetings have been held between the operator and the regulatory body in order to provide for common understanding of the issues. The regulatory body supports commitments of the operating organization to comprehensive assessment of plant vulnerabilities and margins against external natural hazards as well as implementation of additional measures for further safety enhancement of the plants.

The regulatory body is convinced that the process should not be finished by implementation of several individual actions and requires that new challenges as well as required upgrading will be comprehensively evaluated and reflected in the updated Safety Analysis Reports. This requirement applies in particular to the need of updating the Safety Analysis Reports in the area of site characteristics relevant for external and internal hazards as well as plant vulnerabilities and resistance against such hazards. It is specifically required that the comprehensive assessment of the extreme meteorological conditions will be performed and corresponding parts of the SARs will be updated in order to take into account new meteorological data, on-going plant upgrading measures and state of the art methodology.

In addition to existing studies taking into account limited time frameworks the regulatory body will ask for further systematic and comprehensive assessment of plant resistance to the station blackout and loss of ultimate heat sink taking into account the measures for increasing robustness of the plants. Similarly, adequacy of already available analyses for the progression of severe accidents should be assessed. All the assessment should be followed by the evaluation of adequacy of hardware, procedural and organizational provisions for addressing such situations and corrections implemented, as necessary. In particular, occurrence of severe accidents in parallel at several reactors (up to all of them) in the given site under conditions of severely damaged area infrastructure should be considered. It is recommended to harmonize the approaches with the operators of similar reactor types, taking into account all relevant lessons learned from the stress tests. Completion of such works is preliminary expected in about 3 years. The final scope and schedule should benefit and preferably be harmonized within Europe with the use of the peer review of the stress tests.

ACRONYMS

AC	Alternating Current
ACRS	Secondary RHR Reduction Station
AFWP	Auxiliary Feedwater Pump
ALS	Automatic Load Sequencer
AM	Accident Management
ASS	Automatic Standby Start
BC	Bubbler Condenser
BCT	Bubbler Condenser Trays
BDBA	Beyond Design Basis Accident
CDF	Core Damage Frequency
CDFM	Conservative Deterministic Failure Margin
CP	Civil Protection
CPS	Central Pumping Station
CSKAE	Czechoslovak Nuclear Safety Authority
CSS	Containment Spray System
CW	Circulating Water
CWT	Chemical Water Treatment
ČSN	Czechoslovak Technical Standard
DBA	Design Basis Accident
DC	Direct Current
DDF	Depth Duration Frequency
DG	Diesel Generator
DGS	Diesel Generator Station
DW	Demineralized Water
EBO	Bohunice Power Plant
EBO3,4	Bohunice Nuclear Power Plant units 3&4
EC	Emergency Commission
ECC	Emergency Control Centre
ECCS	Emergency Core Cooling System
ECR	Emergency Control Room
EFWP	Emergency Feedwater Pump

EFWS	Emergency Feedwater System
EHV	Extreme High Voltage
EMO	Mochovce Nuclear Power Plant
EMO1,2	Mochovce Nuclear Power Plant Units 1&2
EOP	Emergency Operating Procedures
EPP	Emergency Planning and Preparedness
EPS	Emergency Power Supply
ERO	Emergency Response Organization
ESCW	Essential Service Cooling Water
ESCWP	Essential Service Cooling Water Pump
ESTE	SW prognostic and classification tool for radiological consequences
EU	European Union
EUR	European Utility Requirements
F&B	Feed and Bleed
F&RC	Fire and Rescue Corps
FAIV	Fast Acting Isolation Valve
FDCT	Forced Draft Cooling Towers
FW	Feed Water
FWT	Feedwater Tank
GFU SAV	Geophysical Institute of the Slovak Academy of Science
GIP	Professional Survey Inspection Method for HCLPF Definition
HA	Hydroaccumulator
ha	Hectare, area unit = 10E+4 m ²
HC	Home Consumption
HCLPF	High Confidence Low Probability Failure (Limit for seismic resistance of structure, system and component in existing conditions)
HF	Human Factor
HP	High-Pressure
HPME	High Pressure Melt Ejection
HPP	Hydroelectric Power Plant
HVAC	Heating, Ventilation and Air Conditioning
I&C	Instrumentation and Control System

IAEA	International Atomic Energy Agency
IC	Information Centre
IEP	Internal Emergency Plan
IMS	Integrated Management System
IVR	In-Vessel Retention
KI	Potassium Iodide
L&C	Limits and Conditions
LERF	Large Early Releases Frequency
LOCA	Loss of Coolant Accident
LP	Low-Pressure
LRKO	Laboratory of Radiological Environmental Monitoring
MC	Main Condenser or Monitoring Centre
MCR	Main Control Room
MPB	Main Production Building
MS	Monitoring Centre
MSH	Main Steam Header
MSK64	Macro Seismic Intensity Scale
MV SR	Ministry of Interior of the SR
NEA	Nuclear Energy Agency
NPP	Nuclear Power Plant
NRC	Nuclear Regulatory Commission
OECD	Organisation for Economic Cooperation and Development
PAMS	Post-Accident Monitoring System
PAR	Passive Autocatalytic Recombiner
PCO	Primary Circuit Operator
PFB	Plant Fire Brigade
PGA	Peak Ground Acceleration
PORV	Power Operated Relief Valve
PP	Physical Protection
PP CC	Physical Protection Control Centre
PPE	Personal Protective Equipment
PPE	Personnel Protective Equipment

PPLC	Personnel Protection and Logistic Centre
PRZ	Pressurizer
PRZ RV	Pressurizer Relief Valve
PRZ SV	Pressurizer Safety Valve
PS	Pumping Station
PSA	Probabilistic Safety Assessment
PSHA	Probabilistic Seismic Hazard Assessment
RB	Reactor Building
RCP	Reactor Coolant Pump
RCS	Reactor Coolant System
RHR	Residual Heat Removal
RLE	Review Level Earthquake
RMTS	Radiation Monitoring Technological System
RPCS	Reactor Protection and Control System
RPV	Reactor Pressure Vessel
RUS	Reactor Unit Supervisor
RVC	Relief Valve to Condenser (Steam By-pass Station to Condenser)
SA CRG	Severe Accident Control Room Guideline
SAM	Severe Accident Management
SAMG	Severe Accident Management Guidelines
SBO	Station Black-out
SC	Secondary Circuit
SCO	Secondary Circuit Operator
SCW	Service Cooling Water
SDSA	Steam Dump Station to Atmosphere
SDSC	Steam Dump Station to Main Condenser
SE, a.s.	Slovenske Elektrarne, Inc.
SFP	Spent Fuel Pool
SG	Steam Generator
SG FW	SG Feedwater Tank
SG SV	Steam Generator Safety Valve
SHMU	Slovak Hydro-Meteorological Institute

SL2	Seismic Level 2 (IAEA)
SLB	Steam Line Break
SLOP	Centre of Logistical Support
SMA	Seismic Margin Assessment
SMS	Seismic Monitoring System
SPSA	Probabilistic Safety Assessment for Shutdown Reactor
SR	Slovak Republic
SS	Shift Supervisor
SSC	Systems, Structures and Components
SSE	Safe Shutdown Earthquake
SSEL	List of Equipment for Safe Unit Shutdown after Seismic Event
STN	Slovak Technical Standard
TC	Technological Condenser
TDS	Teledosimetry System
TG	Turbine Generator
TSC	Technical Support Centre
TSC	Technical Support Centre
UHS	Ultimate heat Sink
UJD SR	Nuclear Regulatory Authority of the SR
UPS	Uninterruptible Power Supply
US NRC	U.S. National Regulatory Commission
UVZ SR	Public Health Authority of the SR
VARVYR	Warning and Notification
VHV	Very High Voltage
WANO	World Association of Nuclear Operators
WENRA	Western European Nuclear Regulators' Association
WOG	Westinghouse Owner Group
ZHRS	Back-up Emergency Control Centre
ZHRS	Back-up Emergency Control Centre

0 Introduction

0.1 Objectives of the report

Slovakia is a country with more than 50 years of experience with construction and operation of nuclear power plants (NPPs). Currently there are 4 VVER 440/213 in operation in Slovakia, 2 units in Jaslovské Bohunice and another 2 in Mochovce site. In Mochovce there are also another two VVER 440/213 units with significantly upgraded design under construction. Installed power of operated VVER 213 units is 1,940 MWe. Three nuclear units in Jaslovské Bohunice are currently under decommissioning - the first Czecho-Slovak gas-cooled and heavy water moderated unit A1 and two older type VVER 440/V230 units.

The owner and operator (the holder of the operating permit) of all operating and constructed nuclear units in Slovakia is a stock company Slovenske elektrarne, a.s. (SE, a.s.). The state regulatory authority performing the state supervision upon the nuclear safety of nuclear installations is the Nuclear Regulatory Authority of the Slovak Republic (UJD SR).

In view of the lessons learned from 11 March 2011 Fukushima accident the owner has committed himself to perform so called stress tests on all units in operation or under construction. The task was further specified and its scope outlined in the letter of the UJD SR of 15 June 2011 and several subsequent meetings between the operator and the regulatory body.

This report describes the methodology used and results obtained of the stress tests for 6 VVER units belonging to 3 plants in Slovakia: Bohunice V-2 (further on called EBO3,4) and Mochovce 1&2 (EMO1,2), which are in operation and Mochovce 3&4 (MO3,4) under construction. The report has been prepared by the UJD SR in close cooperation with SE, a.s. based on detailed reports prepared by SE, a.s. This is a summary national report derived from 3 detailed comprehensive reports for each of the plants developed by the licensee.

0.2 Specification and scope of stress tests

On 15 March 2011 the European Commission held an extraordinary high level meeting where energy ministers, regulators, experts and nuclear industry representatives agreed on the introduction of targeted safety and risk assessments (so-called "stress tests") for NPPs in the EU Member States. Following this commitment the Council of the European Union declared on its 25 March meeting that *"the safety of all EU nuclear plants should be reviewed, on the basis of a comprehensive and transparent risk assessment ("stress tests")*. On 21 April WENRA task force issued a preliminary version of its "stress tests" specifications and asked stakeholders for comments. These specifications were brought to the European Nuclear Safety Regulators Group (ENSREG) meeting on 12 May 2011 and then presented and further discussed at the European level. ENSREG Task Force in several subsequent steps has developed the document "Post-Fukushima "stress tests" of European nuclear power plants – Contents and Format of National Reports". Its final version has been approved by ENSREG on 11 October 2011.

In accordance with the specification, stress test is a targeted reassessment of the safety margins associated with extreme natural events challenging safety functions and leading to a severe accident. The assessment is deterministic in its nature and is aimed at verification of implementation of defence in depth in NPPs. The objective of the stress tests was to determine which level of severity of an external hazard the NPP can withstand without severe damage of the nuclear fuel or without significant releases of radioactive materials into the environment. Existing studies did not have this as an objective, since normally the plant

structures, systems and components were designed to cope with the predetermined level of loads (design basis) caused by external hazards. It also means that NPPs are assessed regarding the margins they have to cope in connection with the hazards which were not initially considered in their design.

In accordance with ENSREG specification the assessment in Slovakia was focused on extreme natural events potentially causing extended loss of power supply and/or loss of ultimate heat sink, possibly occurring on several units at the same time. Particular attention was devoted to earthquakes, flooding, and extreme meteorological conditions, which can eventually result in loss of fundamental safety functions both for fuel in the reactor as well as in the spent fuel pool: reactor shutdown and its maintaining in subcritical conditions, residual heat removal and maintaining radioactive materials within the physical barriers. The assessment is complemented by an estimate of limiting parameters and time margins to irrecoverable degradation processes (cliff-edge effects).

The assessment has 3 components:

Assessment of the adequacy of selection of extreme natural events, capability of the plants to cope with such events and determination of the range of events (determination of margins) potentially leading to severe conditions. Extreme natural events relevant for nuclear sites in Slovakia and covered by this report include:

- Earthquakes,
- Flooding from various sources of water (surface water, underground water, dam failures, internal flooding due to an earthquake, bad weather conditions),
- Other extreme meteorological conditions (extreme temperatures, humidity, drought, ice, snow, wind),
- Combination of extreme natural events.
- Assessment of consequences and measures for prevention of loss of safety functions from any initiating event conceivable at the plant site in case of loss of electric power, including station black out (SBO), loss of ultimate heat sink, or combination of both.
- Assessment of severe accident management issues (design and operational provisions available to eliminate challenges to containment integrity after severe fuel damage).

One of the principal objectives of the assessment is to identify ways for the increase robustness of the plant under conditions of extreme natural events.

0.3 Methodology and organization of stress tests by the utility

On 30 March 2011, a project team was established in SE, a.s. The activities were governed and coordinated by the steering committee headed by the DG of SE, a.s. For individual plants the tests were performed in coordinated way (using the same methodology) by 3 different groups of plant engineering staff, involving in total about 30 people. Information for the stress tests was collected from existing design and safety documentation (including Safety Analysis Reports (SARs), Emergency Operating Procedures (EOPs), Severe Accident Management Guidelines (SAMGs), Probabilistic Safety Assessment (PSA) Level 1 and 2) and relevant supporting documentation, additional special analyses, inspections, non-standard tests, engineering judgment and to large extent also plant walk-down.

For determination of safety margins a systematic approach called Configuration Matrix Method was developed and used based on verification of performance of the fundamental safety functions (both related to fuel in the reactor as well as in the spent fuel pools). The approach identifies all feasible

configurations of plant systems capable of maintaining safety functions, considering all possible connections enabled to be configured by NPP basic design and that can be set by personnel in critical conditions caused by extreme external event. The approach verifies presence of all conditions for functioning of these systems (power supply, working medium, instrumentation, environmental conditions, accessibility by operators, availability of procedures) and assesses how eventually these systems can be disabled in their turn with increasing load induced due to external hazards. The evaluation also includes consideration of the human factor, logistic and administrative provision of response in case of events initiated by unlikely extreme external conditions. All relevant information was arranged in a database containing approximately 2,500 structures, systems and components, which will be also used for future plant safety assessments. As basic results of the assessments various configurations of plant systems and available time margins for recovery are identified depending on severity of the external hazard. In MO3,4 units under construction the method of stress tests was partially modified since due to status of the plant construction it was difficult to collect all data necessary for filling in the database and therefore a derived, reduced scope assessment called Success Path Method. The Configuration Matrix Method and Success Path Methods were subsequently adopted by the IAEA as a basis for its independent reviews; the methods are described in the IAEA document "A Methodology for Evaluation of Nuclear Power Plant Protection against the Impact of Extreme Events, SAS/NSNI/IK/WD-2/Rev1, November 2011".

0.4 Relevance of lessons learned from Fukushima accident

Prior to the stress tests the Fukushima accident has been studied in detail. It came out from the study that there are both similarities and differences in the site conditions of Fukushima and sites in Slovakia, as well as in the designs of Fukushima units and VVER 440/V213 units. These items should be taken into account when utilizing lessons learned from the Fukushima accident. Specifically the information about Fukushima Unit 1 with reactor thermal power (1380 MWt) similar to VVER 440 was taken as a basis for the comparison. Some of the observations are summarized below:

Fukushima as well as Slovak sites have increased level of seismicity. However, seismicity level of Fukushima site is significantly higher, corresponding to 10° MSK 64 (with maximum horizontal acceleration ~0.5 g), while for Bohunice it is 9° MSK 64 (with 0.344 g) and for Mochovce it is 8° MSK 64 (with 0.143 g). Nevertheless the seismicity is the relevant issue for Slovak sites which need to be addressed more in detail.

Combination of an earthquake and flooding due to tsunami (main damaging factor in Fukushima) is irrelevant for sites in Slovakia and can be practically eliminated from further considerations. The only meaningful source of external flooding is extreme precipitation. However, differently from tsunami the flooding due to precipitation does not occur suddenly and it is not associated with damaging hydrodynamic wave, therefore time margins exist and damaging impact is much less significant. Nevertheless the flooding caused by extreme meteorological conditions was seriously considered within the stress tests.

In case of station black-out the heat removal from the primary circuit can be ensured in the Fukushima 1 design by natural circulation of steam and water through 2 isolation condensers (normally separated from the reactor by isolation valves) containing altogether 212 t of water available for evaporation. In case of VVER 440/V213 residual heat is removed by natural circulation through permanently connected 6 steam generators containing about 330 t of water.

Both designs have significant amount of zirconium alloys in the reactor core due to use of zirconium not only in fuel cladding, but also in fuel assembly shroud tubes. In VVER 440 there are about 19 t of zirconium which in a hypothetical case of complete oxidation can lead to generation of ~ 800 kg of hydrogen. For

Fukushima 1 the estimate gives about 40 t of zirconium, i.e. there is about twice as much of potential hydrogen produced in Fukushima, but also receiving containment volume is much larger in case of VVER 440/V213. Nevertheless the hydrogen is the issue to be addressed also for VVER 440/V213.

Both designs have quite large volume of water beneath of the reactor core (compared to other PWR designs), which facilitates potential quenching of core debris in the lower plenum, in particular in case of early recovery of reactor coolant system injection in case of a beyond design basis accident. Reactor vessel design of VVER 440 is however less vulnerable to vessel penetration by molten corium due to the fact that that differently from BWR there are no instrumentation and control rod nozzles in the reactor vessel bottom.

Layout of the reactor coolant system and amount of coolant in the system lead in case of station black-out for Fukushima design to early and complete core uncover, while for VVER 440/V213 even with over-conservatively neglecting any operator actions the time margin to core uncover is approximately 10 hours and with simple operator actions using just water inventory in the primary and secondary circuit more than 30 hours.

Both designs have a containment of the pressure suppression type, using water for condensing of steam. However, containment capacity is quite different. In case of Fukushima the containment free volume is about 6,000 m³, and volume of water in condensation chamber 1,750 m³. VVER 440/V213 has much larger containment free volume ~52,000 m³ (therefore less vulnerable for overpressurization) with volume of water in shelf condensation trays ~1,300 m³.

Implementation of severe accident mitigation features were under consideration in Fukushima, but without actions for implementation of relevant measures. Such features are fully covered by the design of MO3,4 under construction, and their implementation is on-going since 2009 in all operation units, with completion scheduled in EBO3,4 and EMO1,2 in 2013 and 2015, respectively.

0.5 Process of safety review and upgrading of nuclear units in Slovakia

The VVER 440 units were originally designed according to the Russian norms and standards, but all main plant components except fuel were fabricated in former Czechoslovakia. Since beginning of operation of the first EBO unit in 1984 all VVER 440 units were subject of systematic safety assessment and upgrading in accordance with new regulations and international standards. The basic document for the safety improvement programme for Bohunice and Mochovce units was the well-known IAEA document "Safety Issues and their Ranking for NPP VVER 440/213" and subsequent safety assessments performed since 1991 by various international missions. Hundreds of hardware and software measures were implemented to resolve the identified deficiencies. In Mochovce all measures were implemented before EMO1,2 commissioning in 1998. In Bohunice implementation was covered by the major investment project "Programme of modernization and safety upgrading of EBO3,4 units" executed from 2002 to 2008.

Relevant SARs updated as appropriate and accepted by the regulatory body are available for all plants. PSA studies Level 1 and 2 are also available, demonstrating compliance with internationally established safety objectives. The latest update of the SAR for EBO3,4 was performed in 2009, for EMO1,2 in 2010. For MO3,4 the Preliminary SAR was issued in 2008, preparation of the Preoperational SAR is currently in progress. Similarly, the latest update of PSA Level 1 and 2 was done in 2010 for EBO3,4 and in 2011 for EMO1,2.

In accordance with the Slovak national legislation all plants in Slovakia are subject to Periodic Safety Reviews (PSRs) with 10 years periodicity. The latest review in EBO was completed in 2008, in EMO in 2009.

Based on the results of the review the UJD SR issued operational permit for subsequent 10 years of operation. The permit is associated with approval of safety upgrading programme of the plants aimed at closer compliance of the safety level with contemporary safety standards. The recently approved programmes include implementation of comprehensive severe accident mitigation measures.

All operating units in Slovakia have been subject of a number of international missions performing independent review of their safety level. Since 1991 in total there were about 20 IAEA missions (site review, design review, OSART,IPSART missions), 6 WANO missions, 2 RISKAUDIT missions and 1 WENRA mission held in Bohunice 3&4 units and Mochovce 1&2 units. Four IAEA missions were specifically devoted to the issue of seismic input and seismic upgrading of the plants.

Based on WANO recommendations, after the Fukushima accident from April to October 2011 the non-standard tests and inspections of equipment important for coping with extreme weather conditions exceeding the basic design were successfully performed on operating units. The tests included long-term operation of diesel generators, delivery of cooling water from the bubbler-condenser to the spent fuel pool, feedwater supply to steam generators from a mobile source, pumping of water from cooling towers to essential service water system, connection of power supply to the hydroplane, and others.

0.6 Structure of the report

The content of the report is in compliance with ENSREG specification as follows.

Chapter 1 contains general information about the plant, focusing on description of all relevant systems providing or supporting the main safety functions and on possibilities to use them under conditions of extreme natural event. Scope and main results of the probabilistic safety assessment are also briefly summarized.

Chapters 2 to 4 are devoted to description of extreme natural hazards specific for nuclear sites in Slovakia. Earthquakes, flooding and extreme meteorological conditions are covered. The description includes characterization of events against which the plants are designed, provisions to protect the plants against such events, and assessment of the range of external events which could lead either to fuel damage or to loss of containment integrity. Potentials to increase robustness of the plant are identified. Chapter 2 covers the earthquakes, chapter 3 flooding, and chapter 4 extreme weather conditions.

Chapter 5 deals with limiting events potentially resulting from the extreme natural events, in particular with loss of electric power and loss of ultimate heat sink, and combination of them. The chapter focuses on overview of consecutive measures available for prevention of severe fuel damage in the core or in the spent fuel pool, including description of all means and evaluation of time margins for recovery of situation in various circumstances.

Chapter 6 deals both with organizational as well as technical aspects of severe accident management. The first part of chapter 6 contains description of the emergency preparedness and response organization, logistic and organizational provision of response to emergency conditions caused by extreme external conditions. The second part of the chapter contains description of currently implemented severe accident management (SAM) implementation project on operated SE, a.s. units, as well as basic 'groups of VVER 213 project modifications and extensions enabling management of severe beyond-design basis events and minimization of severe accident consequences on NPP surrounding by improved containment protection. Considering the fact that this project has been under implementation since 2009 and many modifications have already been installed, the assessment refers to the final state of the upgrading.

Chapter 7 includes summary evaluation of the stress tests.

Appendix 1 briefly describes Slovak legislation relevant for the stress tests.

Appendix 2 provides technical justification of full compliance of the containment of VVER 440 units in Slovakia with relevant IAEA and WENRA safety requirements.

1 General data about the sites and nuclear power plants

1.1 Brief description of the site characteristics and units

Slovakia is an inland country situated in a mild climatic zone of the Central Europe. There are two nuclear sites in Slovakia: Jaslovske Bohunice with 2 operating units of V-2 NPP, and Mochovce site, with 2 operating units EMO1&2 and other 2 units MO 3&4 under construction forming together the Mochovce NPP (see location of the sites on the map, and view of the sites on two photographs below – see the Figure 1, Figure 2, Figure 3).

The license holder for all these units is the joint stock company Slovenske elektrarne, a.s., with headquarters in Mlynské Nivy 47, 821 09 Bratislava.

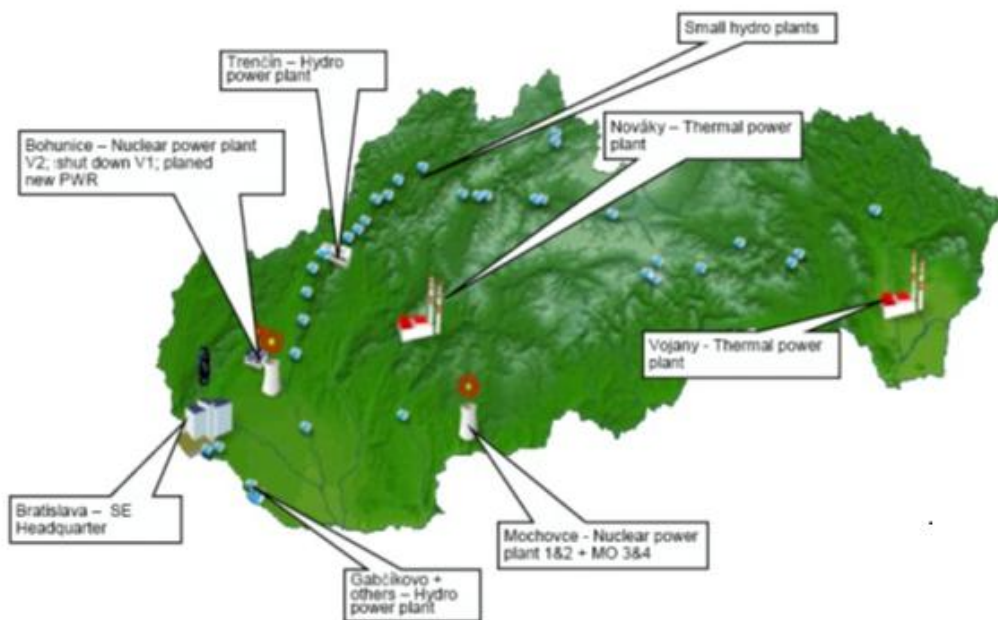

Figure 1: Location of main power plants in Slovakia

Jaslovske Bohunice site is located in West Slovakia; the nearest towns are Trnava, Hlohovec and Piestany. Cooling water for the site is provided from the river Vah, which is about 8 km east from the site with the difference in altitude is more than 20 m. On the river Vah, there is a water reservoir called Slnava with the water area of about 480 ha and the maximum volume of 12.3 million m³. From Slnava, the EBO3,4 units are supplied with service water through the pumping station in Pecenady. The service water off-take from the Slnava reservoir is made by four suckers to the pumping station Drahovce, from where water flows gravitationally by four pipes through a valve shaft to the suction sump of the Pecenady pumping station. From the pumping station, water is supplied by discharging pumps through two discharging lines to the EBO3,4 raw water chemical treatment station.



Figure 2: General view of Bohunice site



Figure 3: General view of Mochovce site

EMO1,2 NPP is situated about 27 km far from the Nitra regional city, 7 km from town Tlmace, 12 km from Levice, and 14 km from Zlate Moravce. The Slovak Republic capital – Bratislava – is about 90 km in south-west direction from EMO1,2 NPP. The reference level of the plant ± 0.000 m is set in the altitude of 242.300 m. For Mochovce NPP cooling water is provided from the river Hron. In Hron near Velke Kozmalovce village there is an artificial water reservoir with the total volume of 2.6 million m³. The water reservoir level is at the altitude of 175.0 m above sea level at the maximum level and 171.5 m at the minimum level. EMO1,2 NPP is supplied by service water from this reservoir. Water is pumped from pumping station Velke Kozmalovce by about 5 km long pipe to the water reservoirs 2x6000 m³ and from there gravitationally flows to EMO1,2 NPP.

The sites are connected to the distribution grid by redundant lines. In both cases, there are 2 independent lines from the 400 kV distribution grid and 2 independent lines to stand-by unit transformers either from 110 kV and 220 kV switchyards. Similarly, in both cases there is a possibility to connect plants to a diverse power sources from hydro stations (different for each of the sites).

1.1.1 Main characteristics of the units

All nuclear units in Slovakia are equipped with pressurized water reactors of Russian VVER 440/V213 design, with relatively small reactor thermal power between 1375 and 1471 MW. The reactor coolant system is located in a large pressure suppression type containment. The units have six loops, isolation valves on each loop and horizontal steam generators with large coolant volume on secondary side of the steam generators. The reactor core is composed of 349 hexagonal fuel assemblies with 126 fuel rod positions each. 37 control rod assemblies have fuel followers underneath their neutron absorbing parts so that efficiency of scram is increased by removal of the part of fuel from the core together with the insertion of the control rods. All units use two steam turbines. Electricity is generated in main synchronous generators on a common shaft with turbine and excitation generator. Power from each reactor unit is led to the power grid through two parallel lines, always from the main generator through respective unit transformer with accessories. Both branches are connected in an outlet substation to a single 400 kV line.

VVER-440's have been conceived as twin units, in mirror spatial arrangement. Most systems and equipment belong to one unit; part of equipment and systems is common for both units. Among the common part of systems and structures there are reactor hall, refuelling machine, spent fuel storage and transport, radioactive waste handling, receipt, storage and transport of fresh fuel, vent stack, access to controlled area, demineralised water treatment system, service water system, cooling water system, diesel generator building.

Basic data about all units covered by this report are in the table.

Plant	EBO3,4 NPP	EMO1,2 NPP	MO3,4 NPP
Site	Bohunice	Mochovce	Mochovce
Reactor type	VVER 440/V213	VVER 440/V213	VVER 440/V213
Reactor thermal power, MWt	1471	1471	1375
Gross electric power, MWe	505	470	470
Plant status	In operation	In operation	Under construction
Date of first criticality	1984-85	1998-99	2013-14
Latest update of Safety Analysis Report	2009	2010	2008
Latest update of PSA Level 1/Level 2	2010	2010-2011	2008, update in progress
Last Periodic Safety Review	2008	2009	-

The spent fuel pit separate for each of the units is located adjacent to the reactor vessel. Spent fuel is cooled in the spent fuel pit approximately 4 to 7 years in a compact storage grid in a pool filled with borated water. Fuel is stored in a compact storage grid in vertical position enabling cooling by circulation of boric acid solution with concentration corresponding to requirements derived from neutron-physical characteristics of fuel. The storage grid consists of hexagonal absorption tubes to which spent fuel assemblies or hermetic cases (for assemblies with damaged cladding) are inserted. There are two grids placed in the pool. The lower (operating) grid is fixed, the upper grid (reserve) is removable, and common for both twin units. Both the operating and the reserves grids consist of two layers. The basic grid has capacity of 319 spent fuel assemblies and 60 hermetic cases for untight fuel (i.e. about 1 fuel loading). In case of short-term storage of fuel assemblies transported out of the reactor during inspections and repairs of the reactor internals, a reserve storage grid is used. It is placed above the basic grid, and it can accommodate 296 fuel assemblies and 54 hermetic cases.

The pool, which is open during refuelling, is connected through a transport passage to the refuelling pool (the area above the open reactor). Outside of fuel manipulation periods, the top of the spent fuel pool is covered and it is isolated from the refuelling pool by a slide gate that blocks the transport passage. This gate forms part of the hermetic confinement boundary during operation.

Generic scheme of VVER 440/V213 systems is shown in Figure 4.

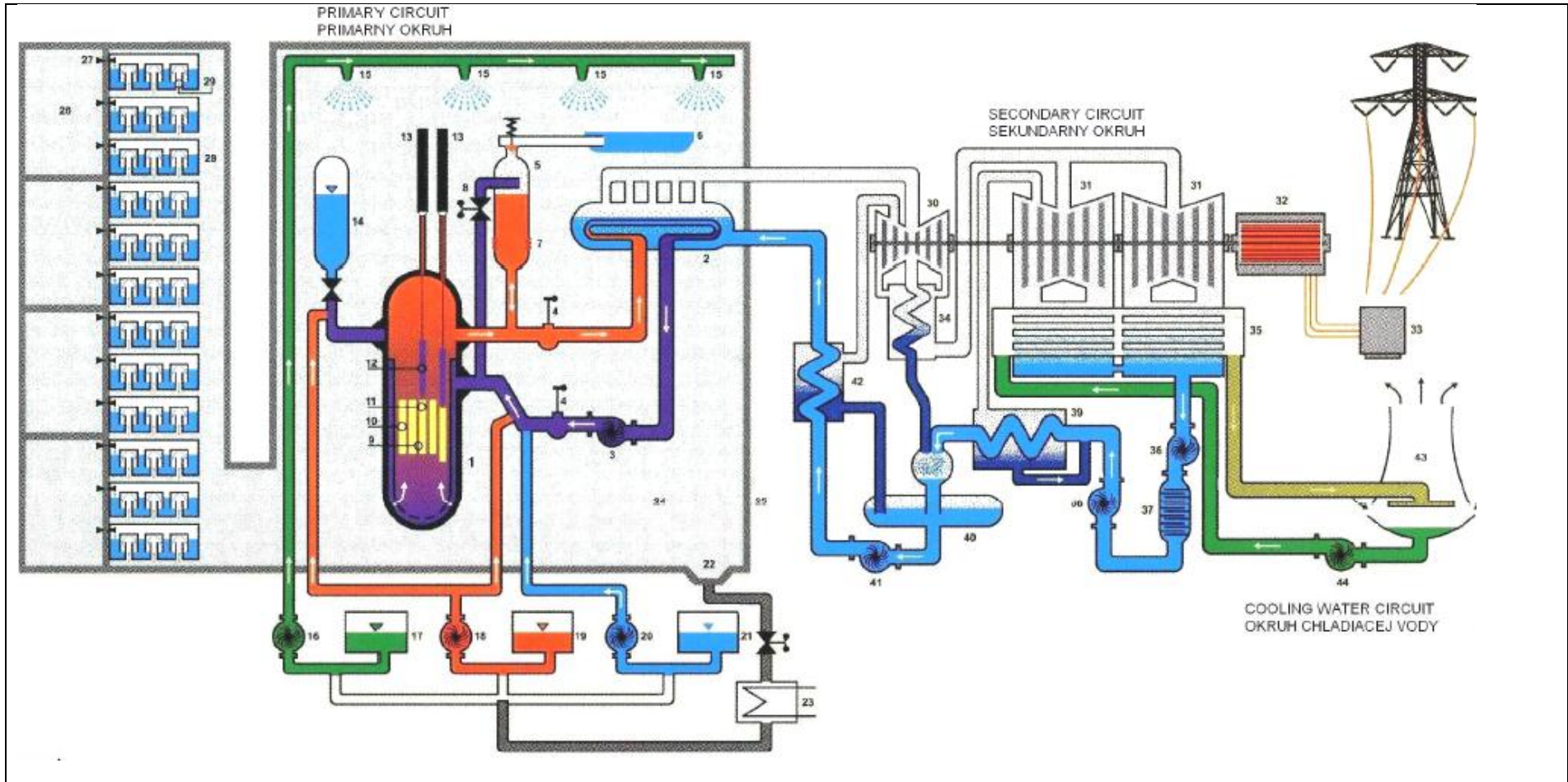

Figure 4: Generic scheme of VVER 440/V213

1 – Reactor, 2 – Steamgenerator, 3 – Main coolantpump, 4 – Main isolating valve, 5 – Pressurizer, 6 – Bubbler condenser, 7 – Pressurizer, 8 – PRZ injections, 9 – Reactorcore, 10 – Fuel assembly, 11 – Automatic control rod (ACR), fuel section, 12 – Automatic control rod (ACR), absorber section, 13 – ACR drives, 14 – Hydroaccumulators, 15 – Spray system, 16 – Spray pump, 17 – Spray system tank, 18 – Low pressure emergency pump, 19 – LP emergency system tank, 20 – HP emergency pump, 21 – HP emergency system tank, 22 – Containmentsuctionsump, 23 – Spray system cooler, 24 – Containment, 25 – Reinforcedconcretecontainmentwall, 26 – Bubbler condenser tower air trap, 27 – Check valve, 28 – Bubbler condenser tower, 29 – Bubbler condenser towerflumes, 30 – HP stage of steam turbine, 31 – LP stage of steam turbine, 32 – Electricalgenerator, 33 – Unit transformer, 34 – Steamseparator and reheater, 35 – Condenser, 36 – Condensatepump, 38 – Condensatepump (stage 1), 37 – Condensatetreatment, 38 – Condensatepump (stage 2), 39 – LP regeneration, 40 – Feedwater tank, 41 – Main electricfeedwaterpump, 42 – HP regeneration, 43 – Coolingtower of circulating water, 44 – Circulating water pumps

1.1.2 Description of the systems for conduction of main safety functions

In accordance with the Configuration Matrix Method, used for assessment of plant safety margins, all plant systems (not only safety systems, but also normal operation systems) should be considered in the configurations used for possible maintaining main safety functions. In accordance with ENSREG specification these systems are briefly described below. The systems are identical or at least similar in all units in Slovakia. The differences are summarized in section 1.4 and whenever necessary significant distinction will be made or commented in the text.

1.1.2.1 Reactivity control

Reactor

VVER-440 (type V213) reactor type assumes two independent reactivity control methods.

In proposed fuel cycles, total core reactivity inventory in cold non-poisoned condition at the beginning of the campaign beginning equals to 14.57-15.19 % compensate this reactivity inventory, and to control the reactor, there are two independent systems affecting reactivity based on various physical and technical principles:

- Reactivity control using the control rods (mechanic method)
- Reactivity control by boric acid concentration modification (liquid absorber) in RCS coolant

Mechanical reactivity control system

is used for compensation of fast reactivity changes during the campaign, reactor power regulation, reactor trip, gradual reactor shutdown and reactor maintaining in sub-critical conditions. The system is based on vertical movement of absorber with fuel followers in the reactor core. It consists of 37 control rods connected with drives installed in the upper reactor block via inserted rods. The control assemblies function by gravity and reliable reactor shutdown by their insertion can be assumed. The assemblies themselves are sufficient for maintaining subcriticality except cold shutdown state. Insertion of the control rods to the core causes extraction of the lower fuel part of the control rods out of the core and insertion of the upper absorption part to the core. Volume of fission material in the core decreases and absorber volume increases, thus attenuating the fission reaction (introduction of negative reactivity).

Reactivity control by boric acid concentration modification (liquid absorber) in RCS coolant

Times to reach desired shut-down condition are listed in the options bellow. Reaching of long term safe subcriticality with uniform distribution of boron in RCS is understood by this condition. However immediate reactor core subcriticality is reach sooner.

Safety systems:

High pressure emergency core cooling systems (HP ECCS)

HP ECCS is classified as the safety system. The system is capable of injecting boron concentrate from the storage tanks to the reactor core in all operational modes, thus increasing the boric acid concentration in the primary circuit to level needed for reaching the sub-critical state in the core. Use of these systems is

connected with heat removal from the core. Considering flow rate by HP ECCS pumps, required RCS boron concentration can be expected within 15 minutes when using the HP ECCS.

Operational systems:

Chemical and volume control system (CVCS)

Chemical and volume control system is classified as safety related operational system. The system is capable of injecting boron concentrate from the boron system storage tanks to the RCS in all operational modes, thus providing for increase and keeping of boric acid concentration in the primary circuit on level needed for reaching the sub-critical state in the core.

Considering required core sub-criticality margin in regimes 1, 2, 3 according to L&C it is possible to increase the boric acid concentration in the RCS only by make-up of required acid without any need to discharge excessive coolant from RCS. There is namely more than 25m³ of spare volume in the pressurizer after unit shutdown. Based on typical shutdown concentration course for the hot condition during campaign it is possible to define the minimal boric acid volume with concentration 39g/kg that has to be supplemented to RCS. Conservatively, about 15 m³ of injected boric acid is sufficient to ensure subcriticality even for the case of natural coolant circulation in the primary circuit. Therefore, this case does not require RCS discharge, which contributes significantly to strengthening of this configuration.

Regimes 4, 5, 6 should have shutdown concentration in the primary circuit (equalling even to shutdown concentration for refuelling) before transition to the regime, and therefore no additional boration is required.

H3BO3 inventory in boron system tanks is sufficient for provision of required core sub-criticality in any operational regime and in any campaign time point.

Specified configuration does not have seismic qualification except for the isolation valves and heat exchangers reactor coolant purification system (RCPS). Pumps of CVCS are seismically qualified only on the side of ESCW. After a seismic event exceeding PGA=0.03g - 0.05 g loss of this configuration should be assumed. In MO3,4 the system is seismically qualified.

When considering external floods, equipment belonging to boron system and CVCS oil system may be endangered by flooding lasting more than 2 days, as this equipment is located in the RB basement. Remaining equipment in considered configuration group would not be affected by external flood.

Impact of extreme temperatures, wind and rain on equipment is considered unlikely due to their installation inside the RB.

Boron system

The high pressure pumps of the boron system are classified as operational system. The system is capable of injecting boron concentrate from the storage tanks to the RCS in all operational modes, thus increasing the boric acid concentration in the primary circuit to level needed for reaching the sub-critical state in the core.

System configuration considered by the project uses routing through the RCPS and specified portions of the CVCS. The primary circuit can be supplemented with boric acid by high-pressure pumps belonging to the boron system. Required conditions in the primary circuit can be reached in about 2.5 hours. Resistance against extreme external events is similar as in the case of the CVCS.

Other systems:

As the units have to be evaluated also with regard to beyond-design basis events, provision of the safety function “Core sub-criticality” also considered the following power plant system configurations exceeding beyond their standard design use.

Chemical and volume control system

HP ECCS tanks can be used as an alternative source of boron concentrate for CVCS using specific dedicated pumps of ECCS. These pumps are used during normal operation to transport boron concentrate to purification systems.

Required conditions in the primary circuit can be reached from 20 minutes to 1 hour, depending on the injection flow. Resistance against extreme external events is similar as in the case of the CVCS.

Spent fuel pool (SFP)

Sub-criticality of the fuel assemblies in the SFP is provided in two independent ways:

- Geometry of the storage grid – fuel assemblies are placed in a triangular mesh with a pitch of 162 mm (in EBO3,4 225 mm) and hexagonal absorption tubes
- Minimal boric acid concentration of 12g/kg in the whole storage pool volume

In normal operational conditions, spent nuclear fuel (in operational Regime 7 also fuel temporarily unloaded from the core) is stored in the spent fuel pool racks and is cooled with boric acid water solution with concentration of 12g/kg. In EBO3,4, fuel is stored in non-compacted racks in the form of a triangular mesh with a pitch of 225 mm. In EMO3,4, fuel is stored in compacted grid with a pitch of 162 mm. According to the design rules sub-criticality in compacted and non-compacted SFP grids must be min. 0.05 ($K_{eff} < 0.95$) without boric acid presence in the coolant and with filling the grids with fresh nuclear fuel.

The requirement – $K_{eff} < 0.95$ – is fulfilled in normal operational conditions of SFP rack, at accident with complete failure of NPP power supply accompanied by coolant circulation interruption in SFP rack resulting in change of coolant density. The requirement on $K_{eff} < 0.98$ is fulfilled also for beyond-design basis accident accompanied by complete water discharge from SFP.

Analyses results prove that the sub-criticality of the spent fuel pool is ensured whenever the fuel is covered with H₃BO₃ solution for the whole range of boric acid concentration 0 – 12g/kg, or partially covered with H₃BO₃ solution with concentration at least 12g/kg for the whole range of coolant density. Fuel sub-criticality in SFP is always guaranteed when heat removal is provided.

1.1.2.2 Heat transport from reactor to UHS

The following systems are used for provision of the safety function “Heat removal from the core”:

- TG condensation system
- Secondary RHR system
- Steam generators with SG SV system or SG steam dump system to atmosphere (SDSA) and relevant supply systems
- Emergency core cooling systems (high-pressure, low-pressure).

The systems can be subdivided into the following groups with regard to their safety classification:

- Safety systems:
 - Steam generators with SG SV / SG SDSA and EFWP
 - Emergency core cooling systems (high-pressure, low-pressure) – Feed & bleed or RHR modes (see Figure 5)
- Operational systems:
 - TG condensation system
 - Secondary RHR system
- Others:
 - This group includes equipment configurations beyond the scope of their original design purpose. Thus this group can include configurations containing both the safety and operational systems, as well as interconnection of different safety trains.

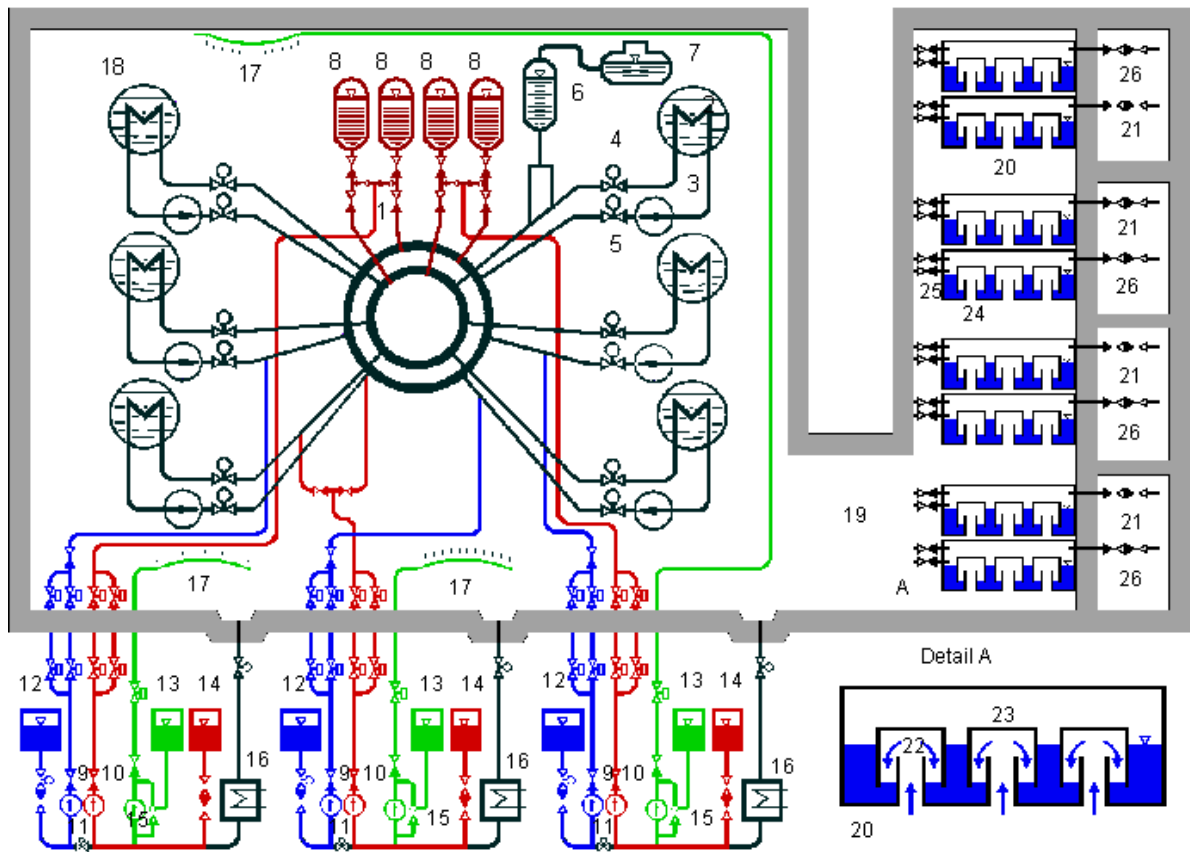

Figure 5: VVER 440 model V 213 ECCS

Safety Systems

Steam generators with SG SV or steam dump station to atmosphere (SDSA)

In case of heat removal via SDSA or SG SV the secondary circuit is not closed. Heat removal on RCS side is performed in natural or forced circulation. Heat transfer from RCS to SC takes place in SG subject to maintaining sufficient water level in SG. Water is supplemented by EFWP and steam can be removed from SG via the SDSA or SG SV. In case of steam removal via SG SDSA water can be supplemented to SG also by normal or auxiliary SG feeding systems. All cases represent secondary side Feed&Bleed strategy. In the following part only configurations with EFWP will be investigated. Configurations with AFWP are included under "other systems".

Resistance against extreme external events

- All EFWP equipment is installed in the lengthwise electrical building or in separated objects under the demineralised water storage tanks and have full seismic qualification i.e. PGA=0.1g in EMO 1,2, 0.15g in MO3,4 and 0.344 g in EBO3,4.
- External floods can endanger EFWP installed in EMO in separated objects under the demineralized water storage tanks on -3.7 m. In EBO3,4 EFWPs are installed on 30 cm foundations at 0.0 m level. Remaining equipment used for Feed & Bleed configurations in SC will not be affected by flooding due to its elevated installation in respective buildings.
- Analyses performed till now do not show impact of extreme temperatures and wind on ESCW circuit.
- Extremely low temperatures are not assumed to cause freezing of EFWP and storage tanks as the system can be heated by operation of pumps.

Emergency core cooling systems

High-pressure emergency core cooling system can be used for heat removal from the core in the primary Feed & Bleed regime. Cold coolant is injected to RCS by HP ECCS pumps. Hot coolant is removed from RCS via PRZ RV and later PRZ SV to the containment. After condensation of expanded RCS coolant in the containment using the containment spray system, the coolant is sucked by HP and LP ECCS pumps from the containment floor and supplied via the CSS cooler directly to suction of HP and LP ECCS pumps which transport it back to the primary circuit and to the spray system nozzles. Heat is removed in the CSS cooler. Cooling medium is ESCW system.

Resistance against extreme external events

All equipment is installed in RB and are seismically reinforced for PGA=0.1g (0.344g).

External floods can endanger HP ECCS pumps, as they are installed in RB basement on -6.5 m. Remaining equipment in considered configuration will not be affected by external flood.

Impact of extreme temperatures, wind and rain on equipment is considered unlikely due to their installation inside the RB.

Low-pressure emergency core cooling system can be used for heat removal in configuration of unit emergency cooling in case of seismic event – RHR configuration. Forced circulation in the primary circuit is provided by LP ECCS pump. After passing through the core, the coolant is supplied to the CSS cooler via the dedicated piping system, cooled and supplied to the LP ECCS pump which transports it back to the primary

circuit. The ultimate heat sink is ESCW system. Resistance against extreme external events is the same as for high-pressure system.

Operational systems:

TG condensation system

Design assumed system configuration uses routing via the power plant SC systems. On the primary circuit side, heat removal from the core is provided by natural or forced coolant circulation (in case of operating RCPs). Heat received by RCS coolant is removed from RCS in SG. Steam produced in SG is supplied via the steam piping to TG condenser. Condensing heat is removed by circulating cooling water (CW). Level in SG guaranteeing sufficient heat transfer from RCS to SC is maintained by condensate pumping from TG MC by TG condensation pumps to the feeding tanks and then by normal and auxiliary SG feeding pumps and pipelines to the steam generators. CW system transmits the heat to the ultimate heat sink - atmosphere via the CW towers. This configuration of equipment is not further considered as reliable due to its complexity and vulnerability.

Secondary RHR system

- The design considers three basic system configurations. They include so called steam regime, water regime and residual heat removal regime. Considering the fact that water regime (stage 2) and residual heat removal regime (stage 3) differ only by number of connected SGs, they will be further on considered as single regime and secondary RHR system will be considered operating either in the steam or water (water-water) stage. The ultimate heat sink in both regimes is ESCW system and heat removal from the core is done either in natural or forced circulation. Secondary RHR technological condenser is the heat exchanger ensuring the heat transfer to the ESCW system. Steam generators are used for heat removal from RCS to SC like in the previous case. The system uses steam pipelines in SC up to the MSH; from there the secondary coolant enters directly the secondary RHR system.
- **In the steam regime**, steam is extracted from SG via MSH and secondary RHR reduction station to the technological condenser, where condensation heat is removed by ESCW system. Condensate flows from the technological condenser to the FWT. Sufficient level in SG is provided by normal or auxiliary SG make-up system. Possible water loss from the system is supplemented from the demineralized water system 1.0 MPa.

Resistance against extreme external events

- All equipment listed above is located either in the lengthwise electrical building or in the turbine hall. After a seismic event exceeding $PGA=0.03g$ loss of this configuration should be assumed.
- The secondary RHR system is operational system. Its design did not consider physical separation of individual redundancies. The system redundancy is provided only with regard to its function. Redundancy at the level of secondary RHR pumps is 3x100%, secondary RHR reduction stations (ACRS) 2x100% and technological condensers (TC) 2x100%. Each technological condenser is cooled by different ESCW redundancy. In case of failure of any ESCW redundancy it is possible to use the reserve 3rd ESCW redundancy. Secondary RHR pumps are installed at one place at 0.0m in the turbine hall; similarly, the technological condensers are also installed at one place on +9.6m in the turbine hall. ACRSs are installed on one place in the lengthwise electrical building on +14.7m.
- External floods pose danger to EFWP installed on 0.0m in the turbine hall. However, considering the topology of this floor, formation of continuous water level can be expected at 0.0 m level only after complete flooding of the turbine hall basement. This situation is in principle possible, but its probability

is negligibly low. This issue is further discussed in chapter 3. Remaining equipment used for steam secondary RHR stage will not be affected by flooding due to its elevated position in respective buildings.

- Available analyses do not show any impact of extreme temperatures and wind on ESCW circuit. Impact of extremely low temperatures on equipment installed in the turbine hall is considered unlikely also considering the temperature of secondary coolant during the steam secondary RHR stage.
- **In the water-water regime**, the secondary RHR technological condenser is used as water / water heat exchanger. SGs and steam pipelines from SG via MSH and complete secondary RHR system are filled with water. Coolant circulation in the circuit is provided by secondary RHR system pumps. Eventual water losses in the system are supplemented from demineralized water storage tanks. In this configuration, minimally one FWT is used connected with the cooling circuit and fulfilling the pressurizer function.

Resistance against extreme external events

- All equipment involved in water-water regime is installed in the lengthwise electrical building, in separated DW storage tank buildings or in the turbine hall. After a seismic event exceeding $PGA=0.03g$ loss of this configuration should be assumed.
- External floods can endanger EFwPs and dosing pumps installed on 0.0m in the turbine hall, and demineralized water pumps 1 MPa installed in separated objects under the demineralized water storage tanks on -3.7 m. These separated objects are interconnected with the turbine hall via the piping channels. Considering the floor topology, flooding of demineralized water pumps can be expected only after flooding the turbine hall to level -3.7 m and EFwPs and dosing pumps after flooding to level 0.0m only after complete flooding of the turbine hall basement. This situation is principally possible, but its probability depends on the flooding duration in the power plant area. Water level in EBO3,4 area would have to maintain on +20 cm for long term (while return period of 10 cm level is 10,000 years). Remaining equipment used for steam secondary RHR stage will not be affected by flooding due to its elevated installation in respective buildings.
- Recent analyses do not show impact of extreme temperatures and wind on ESCW circuit. Impact of extremely low temperatures on equipment installed in the turbine hall is considered unlikely also considering the possibility of SC media temperature stabilization at around 100°C during the water secondary RHR stage.

Other systems

For beyond-design basis events, configurations composed of systems beyond their standard design use should also be considered.

Steam generators with SG SV or SG SDSA

Beyond-design basis events can consider SG make-up using a **mobile feed water emergency source**.

Beyond-design basis events can consider SG make-up using **EFwPs via the SG intermittent and continuous blowdown**. It is also possible to use hardware by mutual crossing of redundancies or using pumps from the neighbouring unit. Considering routing, equipment parameters and their vulnerability, the configurations are similar to the design use of EFWP system.

The **Feed&Bleed strategy** in SC can be also provided alternatively using **AFWP** and SG SDSA. Full operability of the feeding system can be assumed, unless a seismic IE occurred. In this case, AFwPs supply feedwater

from FWT and steam is removed from SG via SG SDSA to the atmosphere. If the demineralized water system 1MPa is available, it can be used to cover water loss in the feedwater tank.

In case of SBO event that is not combined /induced by seismic load, **SG filling by gravity** can be considered as feedwater source directly from the feeding tank not using any normal or auxiliary make-up pump. This is a passive method of SG feeding. Heat removal route is identical with normal SG feeding combined with steam removal from SG via SG SDSA. This strategy is covered by SBO event management in operating procedure PHP ECA-0.0.

Resistance against extreme external events

After a seismic event exceeding $PGA=0.03g$ loss of these configurations should be assumed.

External flooding can endanger the mobile feedwater emergency source connecting points in separated objects under the demineralized water storage tanks on -3.7 m. Separated objects under the demineralized water storage tanks are interconnected with the turbine hall basement via the piping channels. Considering the topology of the sub-base, continuous water level can be expected on -3.7 m only after complete flooding of the turbine hall basement.

From the point of external flooding, AFWPs and DW pumps 1MPa can be endangered. AFWPs are installed at 0.0m in the turbine hall. Demineralized water pumps 1MPa are installed in the demineralization line basement. However, considering the topology of the sub-base, continuous water level can be expected on 0.0 only after complete and long-term flooding of the turbine hall basement. For example, in EBO3,4 water level in NPP area would have to maintain on +20 cm for long term (return period of reaching 10 cm level is 10,000 years).

Remaining equipment will not be affected by flooding due to its elevated installation.

Extreme temperatures and wind can affect operability of the mobile feedwater emergency source. Extremely low temperatures are not assumed to cause freezing of EFWP and storage tanks as the system can be heated by obstruction of hydraulic work of pumps. However, the steam home consumption system is not seismically reinforced. Impact of extremely low temperatures on equipment installed in the turbine hall and electrical building is considered unlikely.

After a seismic event exceeding $PGA=0.03g$ loss of the configuration group with gravity make-up of SG from FWT should be assumed. Equipment is not affected by external flooding, as it is a passive system (also considering elevated installation of equipment).

Impact of extremely low temperatures on equipment installed in the turbine hall and electrical building is considered unlikely also considering coolant temperature during gravity filling and timing of its application at SBO.

Emergency core cooling systems

In the **Feed &Bleed regime using HP ECCS /LP ECCS** pumps enable transfer to HW configurations extending beyond individual safety system redundancies – similar to EFWP in the previous case. Configurations for this strategy can also be created by HW interconnections from various redundancies. Considering routing, equipment parameters and its vulnerability, the configurations are similar to design use of safety systems.

In the heat removal mode using **ECCS** at seismic event it is possible to transfer to configurations extending beyond individual safety system redundancies – similar to the previous case. Configurations for this strategy can also be created by alignment of HW belonging to different redundancies. Considering routing, equipment parameters and its vulnerability, the configurations are similar to design use of safety systems.

Low-pressure emergency core cooling system can be used for heat removal from the core in the Feed & Bleed regime. Cold coolant is supplemented to RCS by LP ECCS pumps. Hot coolant is removed from RCS via PRZ SV to the containment. After condensation of expanded RCS coolant in the containment using the spray system, the coolant is sucked by LP ECCS and CSS pumps from the containment floor and supplied via the CSS cooler directly to suction of LP ECCS and CSS pumps transporting it back to the primary circuit or to the containment system spray nozzles. Heat is removed in the CSS heat exchanger. ESCW is the cooling medium (ultimate heat sink). Like in the previous cases it is possible by alignment of HW belonging to different CSS redundancies, thus increasing robustness of this strategy.

Resistance against extreme external events

All equipment is installed in RBP and have seismic reinforcement for $PGA=0.1g$ (0.344g).

External floods can endanger LP ECCS pumps, as they are installed in RBP basement on -6.5 m. Remaining equipment in considered configuration group will not be affected by external flood.

Impact of extreme temperatures, wind and rain on equipment is considered unlikely due to their installation inside the RB.

Heat removal in the boiling regime at opened reactor

Coolant in the core is heated to the saturation temperature and then starts boiling. Heat is removed from the core due to steam production rising via the refuelling pool to the reactor hall. In this case of heat removal, coolant volume in RCS decreases and failure to provide for adequate make-up can result in core exposing and fuel damaging. Any low-pressure water source can be used for RCS make-up. The following pumps connected with the UPS EPS can be used for RCS make-up: pumps HP ECCS, LP ECCS, CVCS pumps and let-down pumps. Increasing of coolant density is addressed by periodic washing (the method is described in supporting document for TSC). Use of RCS gravity filling from the bubbler condenser channels is an alternative for SBO. This heat removal regime can be combined with heat removal via SDSA (SG SV) after complete filling of the refuelling pool. This will significantly reduce evaporation from the refuelling pool by 60 – 80%. Evaporation of primary coolant to the reactor hall causes radioactivity spreading to the reactor hall and adjacent rooms; thus, it is acceptable only at unavailability of any other heat removal possibility.

Alignment of ESCW redundancies

For specific beyond-design basis events alignment of hardware ESCW redundancies can be used thus utilizing also configurations not considered in the project. Thus the ESCW system robustness is significantly improved since any of ESCW system can be used as ultimate heat sink. Mutual interconnection of ESCW redundancies can be implemented on supply and discharge ESCW lines of secondary RHR system TC.

Possible time constraints for availability of individual heat removal lines and possible time extension of their use by using external measures (e.g. water consumption in the storage tanks and possible inventory make-up)

Operational systems:

Based on conservative manual calculations and comparison with available analyses, the following time limitations can be determined for assumed HW configurations:

Secondary RHR system – steam-water regime

Potential mission time

Regime	Usability	Time to reach the condition (hrs)	Explanation
3	yes	unlimited	Sufficient demineralized water inventory
4	yes	unlimited	Sufficient demineralized water inventory
5, 6	No	-	Low medium RCS temperature

Approximately 4 hours are required for the secondary RHR system start-up from the cold condition. Until then, residual power must be removed in alternative way. In line with use of these configurations, Feed & Bleed can be used in SC during this period, when AFWPs will supply water from FWT to SG and steam will be removed to SG SDSA. Water decrease in FWT is covered from the demineralized water system 1 MPa. During this regime, maximal assumed demineralized water consumption is 120 m3 (in case of unit trip by AO1 from the full power). Value 120 m3 is conservative also for lower power regimes, as the reactor residual power is lower for this case. Secondary RHR steam stage can be used only in case when RCS medium temperature exceeds 100 °C. Therefore, this configuration can be further considered usable only in regimes 1, 2, 3 and 4. Moreover, these configurations can be used in the above regimes in line with this report for unlimited time.

Secondary RHR system – water-water regime

Potential mission time

Regime	Usability	Time to reach the condition (hrs)	Explanation
3	No	-	High medium RCS temperature
4	yes	unlimited	Sufficient water inventory in SC
5, 6	yes	unlimited	Sufficient water inventory in SC

Water-water secondary RHR stage is smooth continuation of the steam stage. In order to operate the secondary RHR system in the water stage, the steam generators and their steam pipes, MSH and the complete system must be filled with water. SG filling requires approx. 144 m3 of water; steam pipes require approx. 160 m3 of water. Total consumption is approx. 300 m3. When considering – with regard to topology of the secondary RHR system – approx. 10% increase of this value (a conservative assumption) to flood the secondary RHR pumps, it is necessary to assume approx. 330 m3 total consumption. Both FWTs provide minimally 220 m3 at nominal levels. Demineralized water reserves for operational DV systems are at least 300 m3 per unit in EBO and EMO.

When considering transition to water-water stage at medium RCS temperature below 140°C, this transition is possible after approx. 12 hours from unit shutdown from nominal power (assumed secondary RHR trend 15°C/hr after the secondary RHR system starts after approx. 4 hours). In line with the previous paragraph, approx. 120 m3 of demineralized water are necessary during the first 4 hours to remove residual power and to stabilize medium RCS temperature on approx. 260 °C. Then, it is possible conservatively consider another 12 m3 of water for FWT cooling during secondary RHR. Approximately 330 m3 are required for filling the secondary RHR circuit. Thus, total consumption is less than 400 m3 of water. Water from two FWTs at nominal level and demineralized water from one storage tanks are fully sufficient for unit secondary RHR and continuous secondary RHR system operation in the water-water stage for residual power removal.

Unit secondary RHR to medium temperature of approx. 140°C can be shortened by 4 hours, if unit cooling is initiated with trend 15°C/hr during the secondary RHR system start-up in the steam regime. As the Feed & Bleed regime is considered in SC during the first 4 hours, it is necessary to determine water consumption for RCS secondary RHR during the first 4 hours. Based on RCS thermal capacity defined in experimental way during the hot tests at unit start-up, additional water consumption of RCS secondary RHR is approx. 5m3/hr at trend of 15°C/hr. This means total water consumption increase by approx. 20 m3. This increase does not mean any risk in the light of the above section. It should be also emphasized that FW consumption integral for unit secondary RHR to given temperature does not depend on secondary RHR trend. Thus, by increasing the trend, time and tens m3 of FW can be saved on residual heat removal till closing the SC cooling circuit.

In case of event occurred in regime lower than 3, water consumption will be appropriately lower. In case that initiating event occurs at the end of secondary RHR steam stage just before transferring to the water-water stage, water inventory in FWT is sufficient for filling the secondary RHR circuit. Unit secondary RHR system could thus work completely without the demineralized water system 1 MPa. Then, the system could be considered to be able to perform given safety function - secondary RHR - without limitation.

Safety systems:

Based on conservative simplified calculations and comparison with available analyses, the following time limitations can be determined for assumed HW configurations:

Steam generators with SG SV or SG SDSA

Potential mission time of configuration with EFWP:

Regime	Usability	Time to reach the condition (days)	Explanation
3	yes	>5(EMO), ~3 (EBO)	Demineralized water inventory in the tank
4	yes	>5 (EMO),~3 (EBO)	Demineralized water inventory in the tank
5, 6	No	-	Insufficient RCS temperature

Values given in the above table for are estimated for minimal water volume per reactor unit according to L&C: EMO 3 x 650 = 1,950 m3, EBO 920 m3.

However, these estimates are conservative. It is believed based on engineering judgement that for specific strategies (e.g. stabilization of core exit temperature and only core residual heat removal temperature) the mission time can be extended for another several days in cases of both plants.

Coolant make-up possibility

Demineralized water tanks can be supplemented from the fire fighting trucks via sockets. This enables mission time extension for configurations with EFWP in the context of stress tests to unlimited time.

Emergency core cooling systems

Feed &Bleed regime using high-pressure ECCS

Potential mission time

Regime	Usability	Time to reach the condition (hrs)	Explanation
3	yes	unlimited	Recirculation regime from the containment floor
4, 5	yes	unlimited	Recirculation regime from the containment floor
6	yes	unlimited	Recirculation regime from the containment floor

Success of the F&B strategy requires availability of one safety system redundancy –HP ECCS pump and relevant boric acid storage tank or sufficient coolant inventory on the SG box floor. This heat removal regime is described in the procedure FR-H.1 entered by the operator at red priority for the CSF “Heat removal from the core“. This strategy is an emergency possibility of heat removal from the core in case of lost heat removal in SC, e.g. due to loss of SG feeding. In case of transition to the recirculation phase, this configuration can be used for long-time, as it is closed cooling circuit. CSS cooler is used as a cooler. The top procedure for the CSF “Heat removal from the core” is SDFR-H.1 intended for events in regimes 4, 5 and 6. However, in fact the Feed &Bleed regime can be used at any time.

Unit emergency primary RHR system at seismic event

Potential mission time

Regime	Usability	Time to reach the condition (hrs)	Explanation
1,2, 3	no	-	Too high RCS pressure and temperature
4	yes (see explanation)	unlimited	Usable only, if pressure in RCS is less than 0.6 MPa and temperature in the cold leg is below 120°C
5, 6	yes	unlimited	Closed circulating circuit

Success of F&B strategy requires availability of one safety system redundancy – low-pressure pump and relevant CSS cooler. This heat removal regime is described in regulation SORNS SDFR-H.1 entered by the operator at red priority for the CSF “Heat removal from the core“. This strategy is an emergency possibility of heat removal from the core in case of lost heat removal in SC. This configuration can be operated for long time, as it is closed circulating circuit.

Other systems

Based on conservative calculations and comparison with available analyses, the following time limitations can be determined for assumed HW configurations:

Steam generators with SG SDSA in combination with AFWP (alternative Feed & Bleed in SC)

Potential mission time for EMO 1,2

Regime	Usability	Time to reach the condition (days)	Explanation
3	yes	10	Water inventory in DW, FW tanks and SG
4	yes	10	Water inventory in DW, FW tanks and SG
5, 6	No	-	Insufficient RCS temperature

Values given in the table are assumed for minimal limit demineralized water inventory for reactor unit 3 x 650 = 1,950 m³, two FWTs at nominal level (220 m³) conservatively decreased by 10% and considering the water inventory in SG for the first approx. 5 hours after shutdown. This assumption is also valid for shutdown from nominal power in regime 1. For lower regimes (2, 3, 4) further time reserve can be assumed up to 3 hours. No operability of these configurations is assumed for regimes 5 and 6, as it is necessary to work in the steam regime Feed & Bleed in SC to maximize the holding time. Water-water regime could occur only after approx. 10 days after reactor shutdown (considering EFWP hydraulic characteristic).

In case of unavailable demineralized water system 1 MPa, possible assumed mission time of this configuration set is approx. 25 hours considering water inventory in SGs for the first approx. 5.5 hours after shutdown.

Potential mission time for EBO 3,4

Regime	Usability	Time to reach the condition (hrs)	Explanation
1, 2, 3	yes	Approx. 34 hours	Water inventory in DW and FW tanks
4	yes	Approx. 34 hours	Water inventory in DW and FW tanks
5, 6	No	-	Insufficient RCS temperature

Values given in the table are assumed for demineralised water operational inventory in one tank for 1MPa pumps (approx. 300 m³) and two FWTs at nominal level (220t) conservatively decreased by 10%. This assumption is also applied for shutdown from nominal power in regime 1. For lower regimes (2, 3, 4) further time reserve can be assumed up to 3 hours. No operability of these configurations is assumed for regimes 5 and 6, as it is necessary to work in the steam regime Feed & Bleed in SC to maximize the holding time. Water-water regime could occur only after approx. 10 days after reactor shutdown (considering EFWP hydraulic characteristic).

In case of an accident on both units it is necessary to use the other DW tank for the other unit. Thus, typical operational configuration will have another – third DW tank available (another 150 m³ of water / unit). Thus, self-sufficiency of the Feed & Bleed strategy with EFWP can be extended by another approx. 70 hours / unit, while considering residual unit power for approx. 34 hours. Totally it can be expected that the F&B strategy with AFWP occurred at IE in EBO locality can ensure the safety function "Heat removal from the core" for approx. 50 hours for each unit without need for water make-up from external sources.

In case of unavailable demineralized water system 1 MPa, possible assumed mission time of this configuration set is approx. 5 hours considering water inventory in SGs for the first approx. 14 hours after shutdown.

Coolant make-up possibility

Demineralized water tanks can be supplemented from the fire fighting trucks via sockets. This enables mission time extension for configurations with AFWP in the context of stress tests to unlimited time.

Steam generators with SG SDSA in combination with EFWP (alternative Feed &Bleed in SC)

Beyond-design basis events can consider SG make-up using **EFWPs via the SG intermittent and continuous blowdown**. It is also possible to use HW by mutual crossing of redundancies. However, with regard to the holding time, these configurations are identical with configurations using EFWPs in the design configuration (strict division after redundancies). These configurations contribute to significant strengthening of the Feed &Bleed strategy in SC.

Steam generators with SG SDSA in combination with gravity feeding directly from FWT

In case of SBO event that is not combined /induced by unit seismic load, gravity SG filling can be considered as feedwater source directly from the feeding tank not using any normal or auxiliary make-up pump. This is a passive method of SG supply. Based on analyses, potential mission time of this configuration is 25 hours considering the water inventory in SG.

Emergency core cooling systems

In the **Feed &Bleed regime using HP ECCS** pumps enable transfer to HW configurations extending beyond individual safety systems redundancies – similar to EFWP in the previous case. Configurations for this strategy can also be created by HW crossing from various redundancies. However, with regard to the holding time, these configurations are identical with configurations using unit safety systems in the design configuration (strict division after redundancies). These configurations contribute to significant strengthening of the Feed &Bleed strategy in RCS when using HP ECCS pumps.

In the heat removal system using **ECCS at seismic event** it is possible to transfer to HW configurations extending beyond individual SG redundancies – similar to the previous case. Configurations for this strategy can also be created by HW crossing from various redundancies. However, with regard to the holding time, these configurations are identical with configurations using unit safety systems in the design configuration (strict division after redundancies). These configurations contribute to significant strengthening of the RHR strategy in RCS when using LP ECCS pumps.

Low-pressure emergency core cooling system can be used for heat removal from the core in the Feed & Bleed regime.

Potential mission time

Regime	Usability	Time to reach the condition (hrs)	Explanation
1, 2, 3	No	-	High pressure in RCS
4, 5	yes	unlimited	Pressure in RCS lower than 0.7 MPa, recirculation regime from the containment floor
6	yes	unlimited	Recirculation regime from the containment floor

Applicability of F&B strategy with LP ECCS depends strongly on conditions, when implementation of this configuration can be considered. Total heat accumulated in RCS is the dominant parameter, as it affects the RCS fast depressurization ability using the PRZ SV below the closing pressure of LP ECCS pumps. Besides the pump itself, these configurations require availability of relevant boric acid storage tank or coolant inventory on SG box floor. This heat removal regime is described in the EOP procedures FR-H.1 or SDFR-H.1 entered by the operator at red priority for the CSF “Heat removal from the core”. This strategy is an emergency possibility of heat removal from the core in case of lost heat removal in SC, e.g. due to loss of SG feeding, and no HP ECCS source available for RCS coolant make-up. In case of transition to the recirculation phase, this configuration can be used for long-time, as it is closed cooling circuit. CSS Cooler is used as the cooler.

Crossing of ESCW redundancies

Specific beyond-design basis events can use crossing of ESCW redundancies, thus using the ESCW redundancy not considered in the original design. Mutual interconnection of ESCW redundancies can be implemented on supply and discharge ESCW lines of secondary RHR system TC.

AC power sources and batteries that could provide the necessary power to each chain (e.g. for driving of pumps and valves, for controlling the systems operation)

Components of the above configurations are supplied namely from emergency power supply, i.e. they can be supplied from DG in case of failed normal or back-up power supply. SG SDSA and FCV on SG pipelines and on all systems on RCS side are also supplied from emergency power supply category I. These valves can be supplied from accumulators. With regard to redundancy, power supply is designed so as to provide redundant supply from one DG in case of operating redundant equipment / lines in given systems. In the database developed for the assessment, for each equipment all available power supply sources are identified. Thus, filtration for given event enables to identify loss of equipment due to failure of all power supply sources.

Need and method of cooling equipment that belong to a certain heat transfer chain; special emphasis should be given to verifying true diversity of alternative heat transfer chains (e.g. air cooling, cooling with water from separate sources, potential constraints for providing respective coolant)

Operational systems:

Secondary RHR system

Essential service cooling water system is the ultimate heat sink in both considered operational regimes. On RCS side, heat is removed from the core in the natural circulation regime (conservative assumption used for generation of configurations).

Steam and water secondary RHR regimes represent two physically diverse configurations, since each regime uses different pumps for coolant circulation in the cooling circuit (AFWPs or DP).

Loss of ESCW causes inoperability of the secondary RHR system, because it is the ultimate heat sink for this system. Also, AFWPs and DP will lose cooling of their glands. Pump electric drives are air cooled.

TC1 is cooled by ESCW system 1, TC2 is cooled by ESCW system 2. ESCW system 3 represents redundant back-up for cooling of each TC.

Atmosphere is the ultimate heat sink for ESCW system. Coolant of ESCW is cooled in ESCW cooling towers. Each system has own set of towers and pumps.

Safety Systems

Feed&Bleed in SC with EFWP

Atmosphere is the ultimate heat sink. Thus, heat removal from the core does not depend on special cooling circuit providing for heat transfer from RCS to the final sink.

ESCW loss causes inoperability of the system, if no power supply is available from BBB, BBC or BBD because of failure of DG providing for autonomous power supply of EFWPs.

EFPWs are air cooled. Their operation does not require any dedicated auxiliary systems.

F&B strategy on SC is a diverse heat removal strategy, as it represents the simplest and most robust heat removal via SC performed with minimal number of equipment.

Emergency core cooling systems (high-pressure, low-pressure)

The ultimate heat sink is ESCW system in all cases. The CSS cooler is used for heat removal in this case.

ESCW loss causes inoperability of these configurations because of the loss of their ultimate heat sink.

In case of failed spray cooler, heat from the core can be removed in the heat accumulation regime in several tens of hours. For accumulation it is possible to use the coolant from ECCS tanks and bubbler condenser trays of JMP system. Totally, more than 2,000m³ of coolant are available.

Heat removal strategy using the emergency systems represents another diverse heat removal mode, but only at the primary equipment level. In long term they depend on ESCW system as ultimate heat sink.

Other systems

Feed&Bleed in SC with AFWP

For these configurations conclusions made for similar configurations using EFWPs are valid. The only difference is in the need to cool AFWP glands with ESCW and use of different source of coolant. Capacity of this source is much lower than the possibilities of configurations using EFWP and its mission time cannot be extended in case of unavailability of demineralized water system 1 MPa.

Gravity feeding of SG from FWT

Atmosphere is the ultimate heat sink, since it is the Feed & Bleed system.

Applicability of this strategy is – like in the previous case – limited by water volume in the feedwater tank that usually does not exceed 250 m³ even for optimistic assessment.

However, because it is a passive system not using pumps, it can be considered as another diverse method for provision of the safety function “Heat removal from the core”.

SG make-up using mobile emergency feedwater source

Atmosphere is the ultimate heat sink. Since it is the feed&bleed mode, heat removal does not depend on another cooling circuit providing for heat transfer from RCS to the final sink.

Loss of ESCW does not cause system inoperability. High-pressure pump on special fire fighting truck does not depend on DG operation, as it is driven by own engine.

Mobile emergency feedwater source does not require any dedicated auxiliary systems.

Use of this strategy is not limited by water volume.

1.1.2.3 Heat transfer from SFP to the ultimate heat sink

There are two different regimes of storage of spent or irradiated fuel considered in SFP design:

Spent fuel from the previous campaigns stored under water in order to decrease activity and residual heat. Nominal level in the SFP in this regime is min. 14.45 m.

The most critical scenario for the event "heat removal loss from SFP" is loading of the whole core to the pool. In this case it is necessary to remove the complete residual heat of the off-loaded core as well as heat of assemblies from the previous campaigns. Off-loading of the complete core is performed not earlier than 10 days after reactor shutdown. The dwell time in this regime is approx. 25 days once in 4 years. In this regime, the assemblies are stored in two grids placed one above the other. In this regime the level in SFP is increased to 21m.

Residual heat is removed from spent fuel by forced cooling water circulation via coolers cooled by Essential Service Water System (ESCWS). ESCWS is the final heat sink (for both design and beyond-design events), loss of the last functional train represent a cliff-edge effect since from this moment it is necessary to remove generated heat from SFP coolant by heating-up, boiling and evaporation.

All existing heat transfer means/chains from SFP

Temperature in the SFP is maintained between 30°C and 40°C during normal operation by two independent trains of SFP cooling system. Each of trains has the capacity to remove residual heat from the previously stored fuel stored as well as maximum heat load from the off-loaded core. Additional third independent train of SFP cooling system has been implemented in EBO in the frame of modernisation project the main reasons were operational issues. There are detailed operating procedures and EOPs describing the way of dealing with unlikely simultaneous failure of all SFP cooling system trains.

Conditions in SFP are constantly monitored and evaluated by monitoring of Critical safety Functions (CSF) in the CSF status tree. Issues dealing with SFP emergency situations (failure of all cooling trains or loss of SFP

integrity and subsequent CSF violation) are described in procedure shut down EOPs for spent fuel pool. Recovery and maintenance of CSFs assumes use of systems otherwise performing functions in normal operating conditions, but which can be potentially used also for this purpose.

Besides the frontline SFP cooling systems several other configurations of equipment providing back-up heat removal function were identified during the stress tests. All specific system and component configurations are included in the configuration matrix database prepared for evaluation of impacts of external events on redundant provision of the safety functions.

Heat can be removed from SFP in the following ways:

- Using the frontline SFP cooling system (two trains)
- By heat accumulation in LP ECCS tanks (3 trains)
- SPF water make-up and steaming to the reactor hall (atmosphere).

Respective information on lay out, physical protection, time constraints of use, power sources, and cooling of equipment are explained in the plant specific technical reports from stress tests.

Operational systems:

Main SFP cooling system - all normal operational regimes

The system consists of two redundant trains each which are designed for residual heat removal from SFP up to 8.14 MW. Third train (EBO only) is capable to remove residual heat up to 1MW and can be used as a partial back-up under specific conditions.

Potential mission time

SFP regime	Usability	Time to reach the condition (hrs)	Explanation
All fuel is off loaded to SFP, level in SFP $\geq 21.0m$, power 4.87MW	yes	unlimited	One of the two main trains
Only spent fuel from previous campaigns in SFP, level in SFP $\geq 14.45m$, power 1.25MW	yes	unlimited	One of the two main trains
Only spent fuel from previous campaigns in SFP, level in SFP $\geq 14.45m$, power 1.25MW	Up to 1 MW – (for operational purposes mostly)	unlimited	Third train (EBO only)

Resistance against extreme external events

All equipment is installed in main reactor building and are seismically qualified up to $PGA=0.1g$ (0.344 g in EBO).

External floods cannot endanger the equipment, as it is installed in RBP on +6m.

Impact of extreme temperatures, wind and rain on equipment is considered unlikely due to their installation inside the main reactor building.

Performed analyses do not show impact of extreme temperatures and wind on ESCWS circuit.

Heat accumulation in LP ECCS tanks

SFP can be cooled by make-up from LP ECCS tanks (with subsequent drainage of heated coolant back into the ECCS system, heat removal is provided by accumulating the heat in the tanks which delays the onset of boiling in SFP. LP ECCS tanks have initial temperature up to 55°C. The margin for accumulation of heat from SFP is additional 35 °C. There are several configurations providing path from ECCS into the SFP.

Potential mission time

SFP regime	Usability	Time to reach the condition (hrs)	Explanation
All fuel is off loaded to SFP, level in SFP $\geq 21.0\text{m}$, power 4.87MW	yes	3	Can be used until LP ECCS tanks temperature up to 90°C.
Only spent fuel from previous campaigns in SFP, level in SFP $\geq 14.45\text{m}$, power 1.25MW	yes	6	Can be used until LP ECCS tanks temperature up to 90°C.

Resistance against extreme external events

Some equipment in the heat removal chain is without seismic qualification. After seismic event exceeding $\text{PGA}=0.03\text{g}$ (0,05g EBO) it is possible to expect loss of their operability.

External floods and extreme temperatures and weather cannot endanger the equipment, as it is installed in main reactor building.

Heat removal from SFP by steaming and heat removal to the reactor hall

After cooling failure, coolant in SFP is heated to the saturation temperature and boiling temperature is reached after 2.7h (regime with fuel in upper grid, power 4.87MW) to 10.7h (normal conditions, power 1.25MW). Heat is removed by steaming from the spent fuel pool to the reactor hall. In this configuration of heat removal, coolant volume in SFP decreases and failure to provide for adequate make-up can result in fuel uncover and subsequent damage. Any low-pressure water source can be used for SFP make-up. Evaporation of coolant from SFP results in radioactivity release to the reactor hall and adjacent rooms; thus, it is acceptable only in case of unavailability of any other heat removal possibilities.

Pumps of LP and HP ECCS systems and primary make-up/letdown systems which are powered from the 2nd category of essential power system can be used for SFP heat removal only in situations when the barrier between the refuelling pool and SFP is removed during regimes 6 or 7.

During the development of the configuration database other configurations have been identified, some of the configurations allow to inject the content of all LP and HP ECCS tanks to the SFP. All the pumps used in configurations have significantly higher flow rate than the most conservative assumption of evaporated coolant volume. SFP can be also supplied by the fire fighting pumps.

However, pumps of some of these configurations are normal operation systems and have non-classified power supplies. The same limitation holds for seismic resistance. Detailed layout and description of the configuration are in the plant specific stress test technical reports.

Gravity filling from the bubbler condenser trays is the most reliable SFP make-up configuration. Use of passive gravity filling from the bubbler condenser trays is useful especially for SBO. Number of trays that can be used depends on water level in SFP, because only channels located higher than actual water level in SFP can be drained to SFP.

Potential mission time

SFP regime	Usability	Time to reach the condition (days)	Explanation
All fuel is off loaded to SFP, level in SFP $\geq 21.0\text{m}$, power 4.87MW	yes	5	More information in chapter 5.
Only spent fuel from previous campaigns in SFP, level in SFP $\geq 14.45\text{m}$, power 1.25MW	yes	21	More information in chapter 5.

This mission time corresponds only for SFP make-up from the bubbler condenser channels due to very wide spectrum of possible configurations. Required SFP make-up per unit in regime of SFP heat removal by steaming ranges from 2 m³/hr (power 1.25 MW) to 8 m³/hr (power 5 MW). In case of extracted core (power 4.87MW), only the first seven channels can be used; in case that only fuel from previous campaigns in stored in SFP (power 1.25MW), the upper nine channels can be used.

Resistance against extreme external events

All equipment used for gravity SFP make-up is seismically qualified to PGA=0.1g (0.344g EBO). External floods cannot endanger equipment since all of it is located in the main reactor building. Impact of extreme temperatures, wind and rain on equipment is considered negligible due to the location of equipment in reactor building.

During the development of the configuration database detailed analyses of potential configuration for heat removal from SFP has been performed. The availability of these configurations depends on the availability of water resources in tanks. In case of complete availability of following resources (bubbler trays, LP and HP ECCS tanks, hydroaccumulators, clean condensate system storage tanks, make-up system deaerators, boric acid storage tanks) the approximate number of SFP autonomy is 14 days or 53 days depending on the content of the SFP. Additional margin can be provided by injection of water by fire brigade.

1.1.2.4 Heat transfer from the containment to the ultimate heat sink

V213 containment is a complex consisting of various systems enabling fulfilment of its safety functions (Figure 6). Technical justification of full compliance of the containment of VVER 440 units in Slovakia with relevant IAEA and WENRA safety requirements is summarized in Appendix 2 of this report.

The containment includes not only the civil part dimensioned for internal over-pressure, but also equipment ensuring its leak tightness. They consist of the following equipment:

- Hermetic liner (external, internal)
- Hermetic penetrations (electric, technological)
- Hermetic doors and manholes
- Covers

- Reactor cover (so called “kolpak”)
- Refuelling pool damper
- Drives of ionising chambers
- Fast-closing valves.

Containment design parameters are as follows:

- Maximal design pressure: 245 kPa
- Minimal design pressure: 80 kPa
- Max. temperature: 129°C
- Maximal humidity: 100% with water droplets
- Maximal ionizing radiation dose: 10^5 Gy / 10 years (this value relates to SG box)

The containment compartments are located inside the reactor building. The containment encompasses the following reactor building areas:

- Steam generators box
- Bubbler condenser tower with accident localisation pit and four gas towers
- HVAC centre
- Refuelling pool (kolpak + damper).

Main containment systems:

Depending on auxiliary functions fulfilled by individual systems, they can be divided into the following groups:

Containment isolation system – its task is to separate the containment from the surrounding environment by closing FAIV on pipes passing through the containment boundaries, thus preventing direct radioactivity release to the surrounding environment. It is activated by increased pressure in the containment.

Containment spray system – this system fulfils two main requirements: The first one is heat removal from the containment during an accident. Coolant sprayed in the containment absorbs heat from the containment and submits it to ESCW in CSS cooler in recirculation regime. At the same time by means of chemical additives contained in sprayed coolant, radioactive iodine and its compounds are chemically bound, thus contributing to minimization of radioactive leaks.

Containment HVAC systems – containment recirculation HVAC systems ensure air cooling in the containment during normal operation. This function is performed by HVAC systems for cooling of SG room and cooling of the reactor cavity and bubbler condenser tower. Coolers in these systems are cooled by the cooling water system and ESCW. Moreover, the SAM project modified parts of air duct system to enable the IVR strategy (details see chapter 6).

Passive pressure suppression system in the containment – this system restricts maximal pressure value in the containment at LOCA or SLB accident in the containment. This activity uses so called bubbler condenser trays of BC system used for condensation of expanding coolant, which has positive impact on maximal pressure course in the containment.

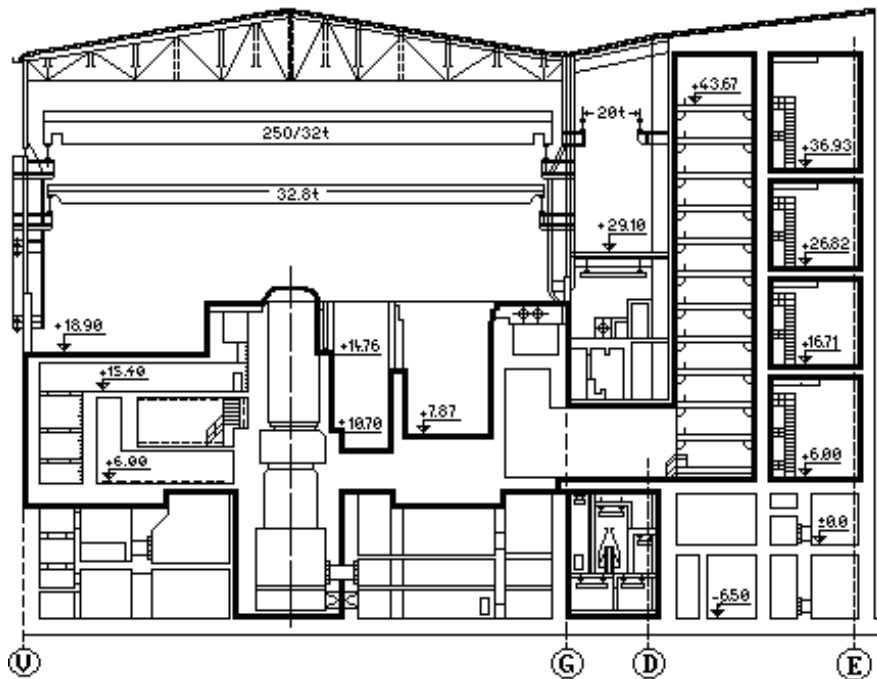

Note: Thick line – external containment boundary

Figure 6: Vertical cross-section of reactor building

Hydrogen management system - see chapter 6.

Bubler condenser system function:

The bubler condenser system installed in the bubler condenser tower is connected with other containment areas by connecting corridor. From there, steam-air mixture is supplied under the bubler condenser trays arranged in 12 levels above each other. Each level is equipped with 10 water trays working in parallel. Steam-air mixture is supplied to each channel by channels consisting of supporting girders, bottoms (welded to girders) and side sheets. Bubler condenser trays are filled with borated water with boric acid concentration 12g/kg. These water seals enable hydraulic sealing between atmosphere in the containment and spaces downstream behind the bubler condensers.

The space above the bubler condenser trays is connected with collecting chambers (air traps) via doubled check valves (dampers 500mm). There are four air traps and each of them is connected with three levels of bubler condenser trays. Two self-closing valves DN250 are installed on the side of the trays at each level; these valves prevent water purging from the channels at small and medium break LOCAs. They enable flowing only in the direction from the space above the channels to the bubler condenser shaft and close completely when the absolute pressure in the bubler condenser shaft is higher than 170 kPa.

Pressure suppression in the containment in case of BDBA and prevention of its increase above design values is passive ensured by the bubler condenser system. Therefore, there are no active systems necessary (e.g. containment spray system) to prevent containment over-pressurization.

During the 90-ies, a number of investigations, including analyses and experiments by utilities, as well as EU PHARE projects and related OECD NEA Expert Group activities, have been performed in order to fully

ascertain the capabilities of the bubbler-condenser. These investigations consisted among others of experiments intended to simulate large break LOCA conditions (as the most challenging ones for the structure) and provided adequate answers to the most important issues related to the condenser function. All the remaining questions were finally resolved in an experimental programme jointly organized by the Hungarian, Czech and Slovak utilities in 2001 and subsequently performed in the EREC facility in the Russian Federation, in close cooperation with the OECD NEA. The conclusions regarding experimental and analytical evidences were summarized in the report NEA/CSNI/R(2003)12 in April 2003.

All existing systems / chains used for heat removal from the containment to the atmosphere

The following systems provide for the safety function "Containment integrity" (this report deals only with heat removal from the containment):

Containment cooling HVAC systems

These systems are used for cooling of the SG room and reactor cavity. The systems are assumed to be used during normal operation only. ESCW system and cooled water system are the final recipients of heat removed from the containment. Heat removal takes place in coolers of these HVAC systems.

Containment spray system

System configuration considered by the design uses routing via the ECCS heat exchanger and RCS coolant recirculation from the containment floor. The ultimate heat recipient is ESCW system. This system is used for heat removal from the containment during DBA sequences connected with RCS or SC coolant leak in the containment.

Since in the stress tests evaluation should be done also for beyond-design basis events, provision of the safety function "Containment integrity" also considered the following configurations exceeding use of systems beyond their standard use.

Containment cooling HVAC systems

It is possible to use systems containment cooling HVAC systems for heat removal from the containment in case of BDBA subject to fulfilment of specific requirements and considering nature of the event. However, cooling capacity of these systems depends on actual operability of chiled water system and ESCW. HVAC system cooling capabilities should be experimentally verified for BDBA.

Containment spray system

In case of BDBA it is possible to consider use of CSS pumps - like in case of strategies using high pressure and low pressure ECCS pumps, in configurations reaching beyond usual safety system redundancies. Configurations for this strategy can in principle be also created by interconnections between various redundancies.

Respective information on layout, physical protection, time constraints of use, power sources, and cooling of equipment

Containment cooling HVAC systems

These systems can operate continuously as they are recirculation systems.

Resistance against extreme external events

All equipment is installed directly in the containment. Therefore, it is not endangered by extreme weather conditions.

Containment spray system

Containment spray system is - after suction transfer to the containment floor - a recirculation system; thus, it can be operated continuously.

Resistance against extreme external events

All equipment is installed in MPB and is seismically qualified .

When considering external floods, CSS pumps will be endangered with probability lower than 10^{-4} for flooding conditions lasting for more than 2 days. Remaining equipment in considered configuration group will not be affected by external flood.

Impact of extreme temperatures, wind and rain on equipment is considered unlikely due to their installation inside the RB.

1.1.2.5 Alternating power supply sources

Off-site power supply

Connections of the plant with external power grid: transmission line and potential earth cable routings with their connection points, physical protection, and design against internal and external hazards

Each reactor unit is equipped with 2 turbo generators. Generator power is supplied to the generator transformer 259 MVA (300 MVA in EBO 3,4), 15.75 kV via encapsulated conductors. After transforming to 400 kV it is supplied to 400 kV EHV substation arranged after the transformer. The substation accommodates 400 kV line transferring generated power to 400 kV EHV switchyard out of the power plant.

Power from both EMO1,2 NPP units is supplied to the 400 kV EHV switchyard Velky Dur (approx. 7 km away) by two lines. Power from EBO unit 3 is supplied via single line to EHV substation 400kV Bosaca at Nove Mesto n/ Vahom approx. 41 km away. Power from EBO unit 4 is supplied via single line to EHV / VHV substation 400/200/110kV Krizovany approx. 20 km away.

The wiring diagram enables – at operation of minimally one reactor unit - power supply of the back-up transformer of the other unit regardless of transition states in the system, thus supplying the complete home consumption of given unit.

Consumers in EMO1,2 can be supplied in the following way:

- One out of four working power plant generators, if the power plant supplies energy to the 400 kV grid via home consumption transformer, and also if its operation is regulated to home consumption operation;
- 2x from 400 kV distribution – through power outlet lines to the electric system when TGs are shut down (400 kV line from Velky Dur switchyard);
- 2 x from reserve unit transformers – from 110 kV back-up power supply after ASS (2x 110 kV from Velky Dur switchyard);

- Connection to Gabčíkovo hydro plant; however, this requires availability of the grid.
- from DG – emergency power supply;
- from accumulators – vital power supply

Consumers in EBO3,4 can be supplied in the following ways:

- One of four power plant generators, if the power plant supplies energy to the 400 kV power grid and also if its operation is regulated to home consumption;
- 2x from the 400 kV distribution – through power output lines to the station grid when TGs are shut down (400 kV line from Bosaca substation and 400 kV line from Krizovany substation);
- 2x stand-by unit transformers (from 110 kV Bosaca substation, from 220 kV Krizovany substation, if outlet to the 400 kV grid is disconnected);
- 1x from 110kV grid from hydro plant Madunice
- from DG – emergency power supply;
- from accumulators – vital power supply;
- from DG 2 x neighbouring NPP V1.

This report focuses on vital and emergency power supplies, since unavailability of the external power grid under extreme events is questionable. Number of consumers at the level of DG and accumulators is limited; it relates to the source capacity. These consumers are supplied from three independent emergency power supply systems. In case of accident, each system can assure nuclear safety of the unit in all regimes and under all operating circumstances of the unit, whereas availability of categories, concerning power and equipage, can assure safe residual heat removal (shutdown) of the unit with 300 % redundancy.

Connection of both NPPs to the Slovak 400 kV transmission system is shown in Figure 7.

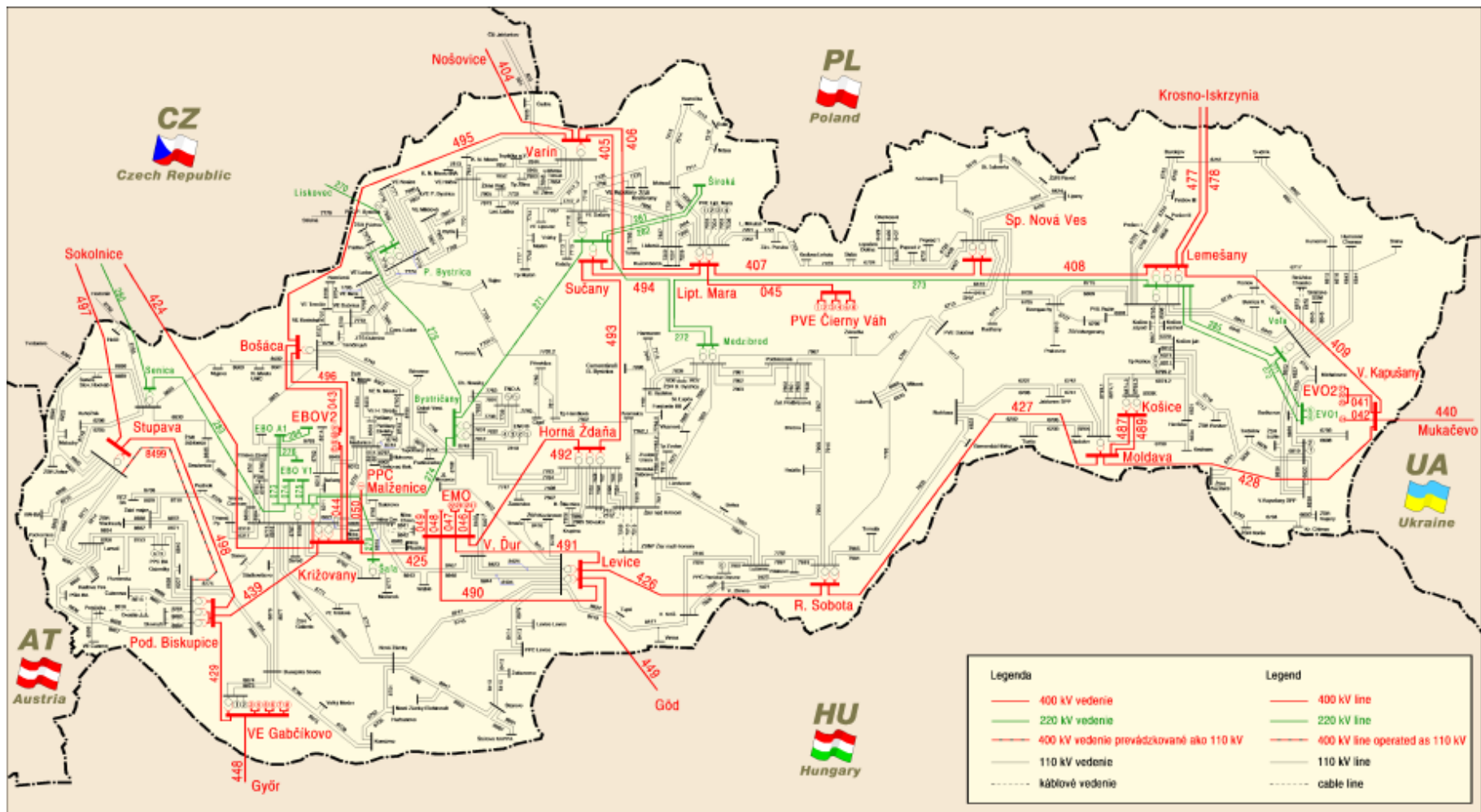

Figure 7: Connection of Slovak NPPs in the Slovak electric system <http://www.sepsas.sk/seps>

Power distribution inside the plant

Main cable routings and power distribution substations

Note: all abbreviations used in this chapter can be found in the Figure 8 and

Figure 9.

Home consumption power supply diagram starts with HC (home consumption) operating transformers 1BBT01(02) supplied from the power outlet. These transformers reduce the voltage from 15.75 kV to 6.3 kV suitable for supplying consumers in HC.

Each operating HC transformer supplies two 6 kV normal operational supply switchboards. Transformer 1BBT01 supplies switchboards 1BBA and 1BBB, transformer 1BBT02 supplies switchboards 1BBC and 1BBD. These switchboards supply HC consumers requiring 6 kV supply voltage due to their output. HC transformer is connected with the power outlet line before the unit transformer with help of encapsulated conductors 15.75 kV / 11 kA. Outlet to 6 kV normal operational power supply substations is provided by encapsulated conductors 6 kV / 2.5 kA.

Back-up sources can be used in addition to these HC operating sources. The back-up source for HC supply of reactor unit 1 EMO1,2 NPP is the back-up transformer 7BCT01 supplied via 110 kV line from Velky Dur switchyard. The back-up source for HC supply of reactor unit 2 EMO1,2 NPP is the back-up transformer 7BCT01 supplied via 110 kV line from Velky Dur switchyard. Both transformers can be used for home consumption supply of unit 1 or unit 2. Back-up busbars are made of encapsulated conductors 6 kV / 2.5 kA. The back-up source for HC supply of reactor unit 1 EBO3,4 is the back-up transformer TR AU01 supplied via 220 kV line the substation at A1 NPP. The other RB has designated back-up transformer TR AU02 supplied via 110 kV line from the substation next to V1 NPP. Both transformers can be used for HC supply of unit 1 or unit 2. Back-up bus bars are made of encapsulated conductors 6 kV / 2.5 kA.

Back-up HC transformers supply back-up 6 kV substations 0BBE and 0BBF and then through back-up 6 kV busbars ZBCA and 7BCB. Back-up busbars are equipped with reserve inlets to individual 6 kV normal operational power supply switchboards. Busbar 7BCA0 is equipped with reserve inlet to switchboards 1BBA, 1BBD, busbar 7BCB0 has reserve inlet to switchboards 1BBB and 1BBC.

6 kV HC switchboards of normal operational power supply 1BBA, 1BBB, 1BBC, 1BBD are connected with consumers requiring 6 kV voltage and with outlets to step-down transformers 6 / 0.4 kV (0.175 kV) marked BFT. These transformers supply 0.4 kV normal operational power supply switchboards 1BFA01, 1BFA02, 1BFB01, 1BFB02, 1BFF01, 1BFF02, 7BFC01, 7BFC01 (switchboards 7BFC are also supplied from unit 2) and 0.175 kV switchboards 1BFE01 and 1BFE02 supplying power parts of RPC system.

6 kV normal operational power supply switchboards are also connected with transformers supplying 0.4 kV consumers of common home consumption for both reactor units. These consumers include CPS, CWTP, make-up water treatment plant, auxiliary building, compressor station, operational building, and administrative building. These consumers can be supplied from both reactor units. Each consumer has inlet both from unit 1 and unit 2 and are operated as necessary.

HC diagram also contains emergency power supply sources and normal operational power supply sources. HC diagram contains three independent identical emergency power supply systems In nominal conditions, these systems are supplied from 6 kV normal operation power supply switchboards connected with 6 kV EPS switchboards in nominal conditions. Interconnection is between switchboards 1BBB-1BDK, 1BBC-1BDM, 1BBD-

1BDL. Each 6 kV EPS switchboard can be connected to emergency power supply – DG. Switchboards 1BDK, 1BDL, 1BDM supply 6 kV consumers of EPS and other electrical equipment of EPS and VPS.

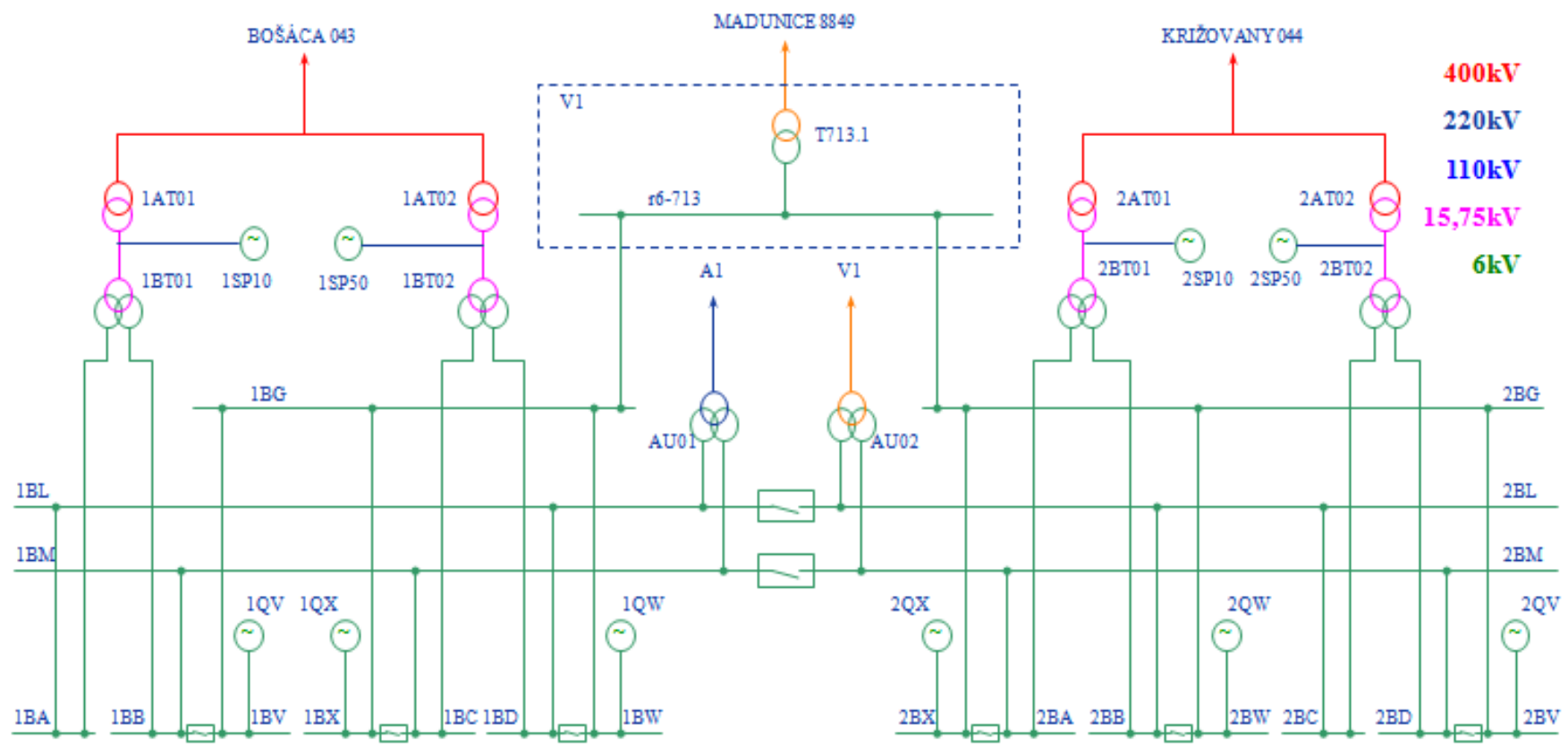

Figure 9: EBO3,4 power distribution diagram

Layout, location and physical protection against internal and external hazards

EMO1,2 NPP back-up supply transformers 7BCT01 and 7BCT02 are located at the external turbine hall wall and are mutually separated with fire wall (wall fire resistance is 120 minutes, steel structure fire resistance is 45 minutes).

HC transformers are located at the external turbine hall wall in line with unit transformers separated with fire wall. The transformer is placed on a chassis with concrete oil collection basin. Transformer location is equipped with stable fire-fighting equipment.

Interconnecting line between HC transformers and 6 kV normal operational power supply substations is provided by encapsulated conductors 2.5 kA/ 6 kV with supporting insulators and air insulation. These conductors can transfer higher outputs than cables.

6 kV switchboards use cabinet switchboards.

6 kV substations are installed in both electrical buildings at floor 0.0 m.

Electric equipment for EPS, besides DGs and forced draft cooling towers, installed in MPB, is located in electrical buildings on floors 0.00 and +9.6m.

0.4 kV distribution is supplied from 6 kV switchboards via transformer 6 / 0.4 kV. They are installed in 0.4 kV substations in proximity of switchboards. 6 kV side of transformers is connected from relevant kV switchboard cabinet with whole plastic cables.

0.4 kV switchboards of operational systems are installed in substations in MPB and in both electrical buildings on 0.0 m.

Relevant supply transformers are installed in the substation together with switchboards.

Measures and devices used for fire prevention and fire spreading prevention in the cable areas follows safety requirements and fire prevention measures defined in STN EN standards.

Main back-up power supply sources

On-site sources that serve as first back-up if offsite power is lost

In case of grid failure, important consumers are transferred to power supply from DG. Connection of any one of three 6 kV DGs with power 2.8MW is sufficient to ensure fulfilment of safety functions.

Three diesel generators 1XKZ1, 1XKZ2, 1XKZ3 serve as alternative home consumption power supply sources at grid failure and can be connected with 6 kV switchboards BMK, BML, BMM.

Basic regime of the DG operation is the “hot reserve” regime. In this regime, DG and its auxiliary systems are prepared for immediate automatic start-up and full loading by appliances of the EPS. DG readiness in this regime is controlled by MCR operators. Unpreparedness or failure of DG is signalled in MCR where a cumulative signal of failure or unpreparedness of DG is led.

The emergency power supply system ensures power supply of consumers necessarily required at transients and in emergency situations related to protection of individual NPP barriers.

The emergency power supply system has three independent trains. Each train consists of following equipment:

- Diesel generators - 1XKZ01 – 03 – serve as independent power sources at failure of operational and back-up home consumption power supply sources. During normal unit operation, DGs are maintained in the “hot

stand-by” condition, i.e. at temperatures close to operating one and they are started automatically, if needed. DG power is led to 6 kV system switchboards (1BDK, 1BDL, 1BDM).

- 6 kV switchboards of EPS - 1BDK, 1BDL, 1BDM – serve for supplying important consumers.
- 0.4 kV section switchboards of EPS - 1BMK01, 1BML01, 1BMM01 are intended for supplying system distribution switchboards and other consumers at 0.4 kV level, necessary for provision of nuclear safety in operating and emergency unit regimes.
- 0.23 kV system switchboards of EPS - 1BMK02, 1BML02, 1BMM02 supply controlled rectifiers of EPS.
- Transformers 6/0.4 kV and 6/0.23 kV.

EPS immediately relates to the reloading system, which after recovery of voltage in 6 kV sections, assures gradual connection of safety important consumers. In Mochovce NPP, the automatic load sequencer (ASL) is a part of ESFAS.

6 kV reactor unit home consumption substations consist of four sections; of them, three are divided to two parts by two serial connected section power switches – normal power supply substations (1BBA, 1BBB, 1BBC, 1BBD) and emergency power supply source of substations - 1BDK, 1BDL and 1BDM.

During normal operation, all four sections are supplied from operating inlets from step-down transformers (1BBT01, 1BBT02), or through 6 kV emergency power supply busbars (7BCA, 7BCB) from the back-up transformer 7BCT01. At loss of voltage of operating and stand-by sources, EPS substations are automatically disconnected from normal power supply substations, and DGs - 1XKZ01, 1XKZ02, 1XKZ03 are connected to them.

Redundancy, separation of redundant sources (by structures or distance) and their physical protection against internal and external hazards

DG is independent on operating and back-up home consumption power supply. DGs are installed separately in seismically resistant building split to six individual cells. Each cell contains a diesel engine, AC generator, 24 V DC supply, measuring, signalling and control instruments, HVAC, control room, electric substations and auxiliary DG systems.

Time constraints for availability of these sources and external measures to extend the time of use (e.g. fuel tank volume)

Minimal inventory of diesel fuel is 330m^3 / reactor unit according to L&C, whereas the fuel inventory per one DG cannot fall below 55m^3 . Fuel is uniformly distributed for three DGs. One DG has fuel inventory for 10 days. Fuel consumption at nominal diesel engine power 3.3 MW is 644 kg /hr.

External fuel system provides fuel inventory for continuous operation of 6 DGs (each 2.8 MW) for minimum 10 days and provides NPP emergency power supply together with DGS in case of NPP failure states. The fuel system, like DGS, observes the requirement of three independent power supply sources (trains) for the most important NPP consumers.

Long-term DG run with full load has confirmed that average diesel fuel consumption is about 500 litres/hr in EMO1,2 and EBO 3,4 (at three day run of DG test during the stress test conduction in EBO3,4). External fuel in the Bohunice site is available also in the neighbouring NPP V1 which is under decommissioning.

Diverse permanently installed on-site sources for back-up power supply

All diverse sources that can be used for the same task as the main back-up sources or for more limited dedicated purposes (e.g. for heat removal from the reactor when the primary circuit is intact, for operation of systems that protect the containment integrity after core meltdown)

EMO 1,2 NPP:

As an alternative source for EPS during beyond-design basis failures of the emergency power supply (SBO) in the Mochovce NPP, a diverse source independent from network industries (gas, pipeline fluids) – external autonomous source for emergency power supply – should be used. Its task is to ensure power supply to selected power consumers of safety systems in case of total or partial home consumption failure. Its use is assumed during long-term failures or inoperability of emergency power supply trains.

The nearest diverse electricity source is DG station 16 x 2 MWe installed in 400 kV switchyard in Levice. If needed and if lines to Velky Dur switchyard are available, DG can be quickly connected to EMO NPP.

As an alternative, hydropower plant (Gabcikovo) is considered in the design; however, this alternative requires the power grid system alignment.

In the frame of SAM project additional SAM DG will be installed to provide power for equipment needed for severe accident mitigation. The diesel will be 6 kV and 1,200 kW type. It will cover SAM, including SBO cases.

In addition to SAM DG, there will be another mobile diesel generator 0.4 kV for each unit (primarily dedicated to recharge batteries). In addition they can be connected to vital power supply switchboards if necessary.

One mobile rectifier is available for back up charging of EMO1,2 accumulators.

EBO 3,4 NPP:

One DG including relevant switchboards and consumers is being installed to be used at SAMs connected with failure of all back-up power supply sources.

SAM diesel generator will be connected with HC wiring diagram via BG switchboard. This diesel generator will be connectable with any redundancy.

The diesel will be 6 kV and 1,200 kW type. It will cover SAM, including SBO cases. Two stable rectifiers will be also installed with possible connection with two unit accumulators.

In addition to SAM DG, there will be another mobile diesel generator 0.4 kV for each unit primarily dedicated to recharge batteries. In addition it can be connected to vital power supply switchboards if necessary (connections are already installed).

One mobile rectifier is available for back up charging of EBO3,4 accumulators.

Respective information on location, physical protection and time constraints

SAM diesel generator will be enabled to be started manually from the main control rooms or from the emergency response centre in case of SA. DG power is dimensioned both for SAM, and SBO. After automatic start-up, voltage will be supplied to relevant 6 kV substations and 0.4 kV substations of both units. Remaining operations will be manual. Some of them will be remote, the other ones local.

Mobile DGs 0.4 kV will be also prepared for transport, if necessary. They will include also cabling for connection of dedicated switchboards and consumers, and diesel fuel inventory.

Mobile rectifier is prepared for transport and connection with any switchboard or 63 A socket on inlet side and with any direct voltage switchboard to charge up to 160 A to accumulator.

In Bohunice, 6kV DG in NPP V1 can be connected manually in cooperation between EBO3,4 and NPP V1 .

Other power sources that are planned and kept in preparedness for use as last resort means to prevent a serious accident damaging reactor or spent fuel pool

Potential dedicated connections to neighbouring unit or to nearby other power plants

Each safety section of 6 kV substations BKD, BDL, BDM can be mutually interconnected with essential power supply section of the neighbouring unit.

In Bohunice, selected emergency power supply consumers in both units can be supplied from one dedicated hydro generator (power 5MW) from approx. 10km distance of Madunice HPP. Power supply is designed for the condition of grid disintegration and failure of EBO3,4 DG. Hydro generator power is supplied to 110kV substation in NPP V1 via 110kV line. Here, 6kV switchboard r6-713 used as the 3rd grid, is supplied via 10MVA transformer. This grid was originally used also as DG back-up in NPP V1. After its shutdown, the 3rd grid is no longer necessary. On the contrary, DGs in NPP V1 can be connected as alternative source to hydro generators. There are totally 3 sections available in NPP V1.

Possibilities to hook-up transportable power sources to supply certain safety systems

Safety sections of 0.4kV EV, EW, EX were provided with special fields for “accident management” where mobile 0.4kV DGs can be connected. They are in the procurement process now. Prepared outlets are equipped with circuit breakers enabling connection of mobile DG 440 kVA. In Mochovce, the same solution is in the procurement process. Prepared outlets are equipped with circuit breakers enabling connection of mobile DG 440 kVA.

Information on each power source: power capacity, voltage level and other relevant constraints

In EBO3,4, connection to Madunice NPP is available. The hydro power plant has 3 hydro generators, each with power 18MVA. This power, and the whole transmission route are sufficient to cover all EBO3,4 needs. Power of alternative source DG 2 x 1,600kW in NPP V1 is sufficient for EBO3,4 needs.

1.1.2.6 Batteries for DC power supply

Description of separate battery banks that could be used to supply safety relevant consumers: capacity and discharge time in different operational situations (regimes)

The vital power supply is intended for supplying appliances with allowable power supply interruption up to 1 second. There are three independent vital power supply trains.

In EMO 1,2 each of three vital power supply trains is equipped with accumulators with capacity 1,500 Ah 220V, 300 Ah 24 V and 2.000 Ah 24V. The accumulators were designed for 2 hours operation. The main consumer of the 220 V accumulators is emergency illumination. Based on evaluation of measured data during the test, they will remain operable for 9 hours at least without recharging.

In EBO 3,4 design requirements for accumulators established that minimum charging period is 2 hr. However, based on evaluation of measured data during the test, the results are almost the same as in EMO1,2 mentioned above.

1.1.2.7 Consumers supplied by individual accumulator sets: valve drives, control systems, measuring instruments, etc.

Accumulators supply systems important to safety, e.g. pumps. They also supply inverters used also for powering of I&C systems, valves and FAIVs (consumers interesting namely for heat removal from the core, SFP, containment and reactivity control).

1.1.2.8 Physical location and separation of battery banks and their protection from internal and external hazards

Accumulators are installed in separated rooms in RB on level 0.0 on ~30 cm high basements. Cabling for individual systems is separated.

1.2 Significant differences between units

As far as reactor cooling circuits and safety systems are concerned there are no significant differences among the units. In particular there are practically no differences between individual units located on the same site, i.e. EBO3,4, EMO1,2 and MO3,4. All modifications made during plant operation are first implemented on one unit and subsequently after their successful evaluation to other SE, a.s. units. Therefore, similarity among the units on the same site is maintained over their lifetime.

Nevertheless there are certain differences between units on different sites. This fact results first from different characteristics of the sites, but also from different period of construction of the units. For example, different characteristics of the sites are reflected in differences in robustness of the seismic design, and in systems for provided cooling water and for plant connection to the electric grid. More specifically, these differences can be summarized as follows:

No.	Primary system differences
1	Discharge of HP ECCS pumps in EBO is equipped with automatic threeway valve and control valve (in EMO only isolation valves). ECCS tanks in EMO are equipped with electric heaters.
2	HA volume is 60 m ³ in EMO, in EBO 70 m ³ , EMO HA are equipped with electric heaters (58-60°C). Pressure in EBO HA is approx. 3.5 MPa, in EMO approx. 6 MPa.
3	Spent fuel pool cooling system in EMO does not include third train with approx. 1 MW cooling capacity.

No.	Secondary system differences
4	Two steam dumps to atmosphere are installed on each of EMO SG main steam lines (nominal flow of each is 200 m ³ /hr) – only one SDSA on each SG steam line can be operated in AUT regime. In EBO there is only one SDSA on each SG main steam line and can be operated in AUT regime.
5	Two fast acting valves are installed at EMO on each SG main steam lines (one with HP air drive, other with nitrogen – oil drive). One fast acting HP air driven valve is installed at EBO on each SG main steam line. In EMO, there are also checkvalves on main steam lines which are not installed in EBO.
6	In EBO, only two primary RHR trains are present, in EMO there are three trains.

No.	Secondary system differences
7	There is different routing of EFW lines in EBO and EMO.
8	ESCW system in EMO offers 3 pumps for train and 6 per two units, in EBO there are only 2 pumps per train and 4 per two units.
9	Layout of secondary piping between EMO and EBO differs in some minor cases which may offer to develop different configurations of pipe routings (e.g. a pipeline connecting the main feedwater header directly with feedwater tanks remains in EMO).
10	In EMO, each SG FW or EFW line in the containment is equipped with two checkvalves, EBO uses only one checkvalve.
11	Three 770 m ³ EFW tanks per unit in EMO, three common 1065 m ³ EFW tanks for both EBO units.
12	Separated ESCW pumping station building in EMO. Common pumping building for ESCW and CW is in EBO.
13	Differences between raw water make-up systems.
14	Different relative elevation of buildings on individual sites.
Poradové číslo	Electrical system differences
15	Differen connection to the electrical grid and houseload scheme.

In spite of similarity in basic technological equipment, the differences have some effect on management of severe external events, as shown in particular in chapter 5 of this report.

MO3,4 units in accordance with the design in addition to new I&C/electrical systems will be equipped with all systems needed for mitigation of severe accidents in accordance with the requirements for new reactors. For implementation of these systems in operating reactors there are ongoing projects initiated in 2009 with schedule for completion in 2013 in Bohunice and 2015 in Mochovce (the date of completion was changed from 2018 to 2015 as a results from Fukushima lessons learned). In Bohunice, significant parts of the hardware modifications were already implemented.

1.3 Use of PSA as part of the safety assessment

For EBO3,4 units the PSA Level 1 is being systematically developed since 1994, considering as initiators the internal initiating events, internal as well as external hazards, and operation at power as well as shutdown operating regimes. Initiating events occurring in the spent fuel pool are covered, too. All 10 different plant states are considered. The study has been regularly updated taking into account the progress in methods and data used. Latest update leading to more conservative results was made in 2010 using more plant specific data and human reliability analysis performed by internationally recognized methodology. According to the latest update, the CDF both for operation at power as well as for low power and shutdown regimes is significantly lower than established for existing plants and close to the required value for new plants. The largest contributor to CDF at power operation is the total loss of power supply (32.3 %), regarding the additional equipment failure the most significant is a failure of a mobile source of feedwater supply and an operator failure to recover the feedwater supply. For shutdown regimes the largest contribution to CDF is a small leak initiated by a wrong human actions (43.7 %), the second largest is total loss of power supply (17.1 %). Earthquakes contribute top CDF for operation at power ~1.3 %, for shutdown regimes 0.6 %. Other external hazards contribute to CDF by less than 1×10^{-8} /year. Dominant contributors to the risk are human errors, so that the more effective training in already identified areas (prevention of small leaks initiated by operators, recovery of power supply, recovery of

natural circulation, residual heat removal and control of the small leaks during reactor shutdown) can significantly reduce the risk.

First PSA Level 2 for EBO 3,4 has been developed in 2001 and also updated in 2010. Since 2000 the full scope real time risk monitor is in use in the main control room. The largest contribution to LERF is the cold shutdown regime with the open reactor. The measures under implementation since 2009 (with completion in 2013) include the mitigation features for severe accidents and automatic start up of the low pressure injection at low level in open reactor. These measures will reduce LERF for all plant states by about 60 %.

PSA studies for Mochovce 1&2 units have similar scope, although performed with certain delay due to later start up of the plant. PSA Level 1 latest update including also the plant power uprate to 107 % is from 2010. The largest contributor to the CDF is an interfacing LOCA, 44.3 %. Human errors contribute about 85 % to CDF. Risk monitor is used since 2005.

The reference plant for MO3,4 is EMO1,2, but taking into account the modification embedded in the design. The largest contribution to CDF represents the plant shutdown regimes. The largest contribution for CDF at power is small break LOCA, for shutdown regimes it is again the small leak initiated by the operator). PSA Level 2 is in progress but due to implementation of safety upgrading measures it is expected that the total LERF (i.e. taking into account the contribution from the full performance, low power and shutdown reactor states) is less than $1E-6$ per year as is recommended by the IAEA for new reactors.

See the Figure 10 indicating various contributors to the overall CDF.

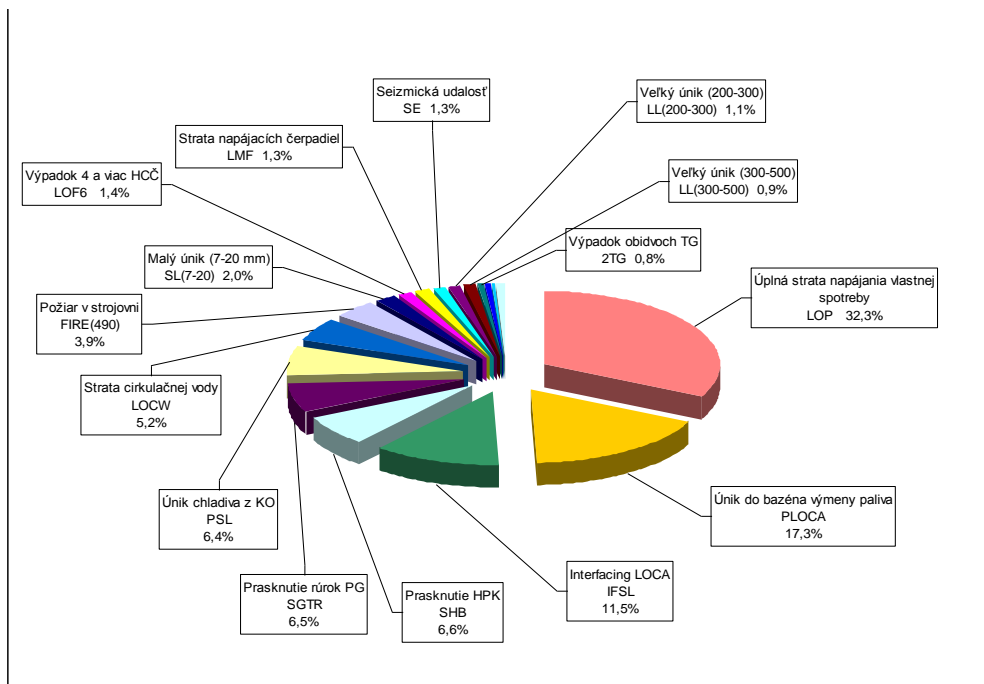

EBO Unit 3

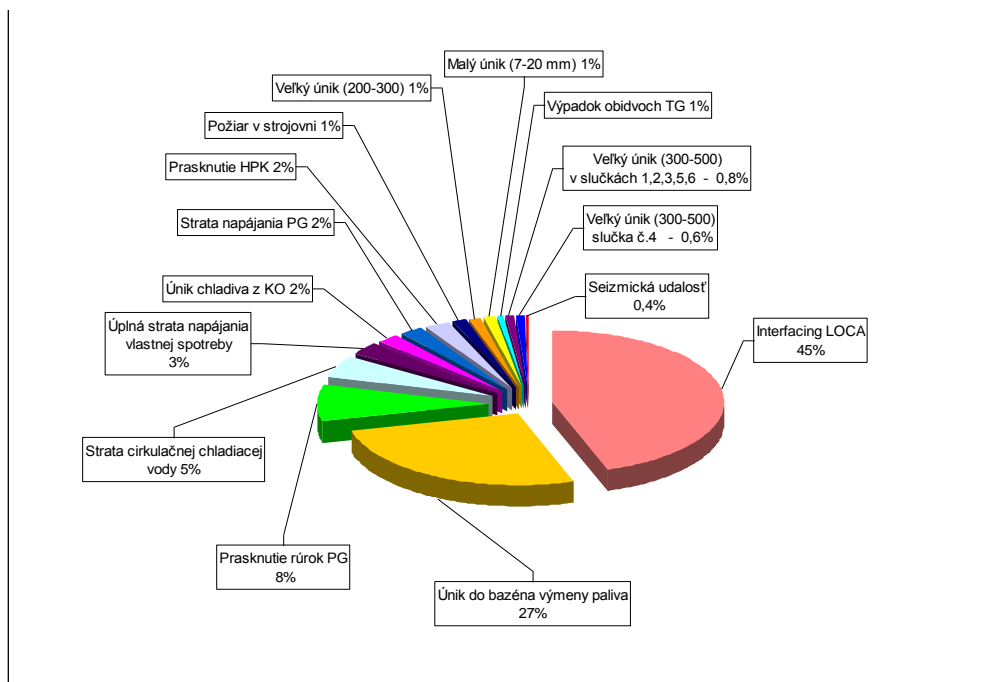

EMO Unit 1

Legend:

Malý / veľký únik – small / large leak

Požiar ... - fire in the turbine hall

Prasknutie HPK / rúrok PG – rupture of MSH / SG pipes

Strata napájania PG – loss of SG supply

Únik chladiva z KO – coolant leak from PRZ

Úplná strata ... - complete home consumption supply loss

Strata cirkulačnej ... - loss of circulating cooling water

Únik do bazéna ... - leak to refuelling pool

Výpadok oboch TG – failure of both TGS

Slučka – loop

Seizmická udalosť – seismic event

Figure 10: Contributions of initiating events to the core damage frequency for power operation

2 Earthquakes

2.1 Design basis

2.1.1 Earthquake against which the plants are designed

2.1.1.1 Characteristics of the design basis earthquake (DBE)

For preparation of basic design for EBO3,4 NPP the report of 1970 “Geological History, Tectonic Development and Seismicity in Jaslovske Bohunice” developed by GFÚ – SAV Bratislava was used. The report specified the maximum credible earthquake of Bohunice site with intensity of 6 – 6.5° MSC (Mercalli - Cancani - Siebert) at most (bal) or $M = 4.2$ of Richter’s scale, according to data related to an earthquake of 1906. According to the report the peak horizontal acceleration was defined as $PGA=0.025g$. According to the standard CSN 730036 for constructions in seismic areas and places with intensity of 6° MSC or acceleration below 0.03 g the earthquake effects need not be considered in the original plant design. **In subsequent steps, the original value was increased up to the current value 0.344 g.**

Similarly, for Mochovce site originally the seismicity level of 6° MSK 64 with horizontal free field acceleration $PGA = 0.06 g$ with return period once per 10,000 years was specified. The accelerogram was derived from the earthquake in Vrancea in Romania from 1977. **In subsequent steps, the original value was increased up to the current value 0.143 g.**

2.1.1.2 Methodology used to evaluate the design basis earthquake

Initial seismological studies for the EBO site were prepared in 1969 – 1970 in compliance with CSN 730036 – Seismic Loading of Civil Constructions. Seismicity of the site was set to 7° of the MCS (Mercalli – Cancani – Siebert) scale using a map of seismic areas in the Czechoslovak Socialist Republic territory (see Figure 11). In compliance with the aforementioned standard (Article 31), a special study “Geological History, Tectonic Development and Seismicity of Jaslovske Bohunice” was prepared (06/1970) detailing EBO site seismicity. The document described seismicity of the site with important earthquake areas, seismically active geological fractures, seismic activity forecast with definition of maximum credible earthquake and in conclusion with expert opinion on seismicity with determined value of the maximum probabilistic earthquake as given above. According to the study, the strongest probable earthquake in Jaslovske Bohunice may be the earthquake with 6 – 6.5° MCS, corresponding to 4.2 of the Richter’s scale. The terrain in this territory is flat with maximal slope of 1°, which indicates favourable conditions excluding secondary earthquake effects, in particular a risk of gravitational dumping. It was stated that within the time period of 200 years, the strongest probable earthquake in Jaslovske Bohunice area will reach $M = 4.2$ of the Richter’s scale (i.e. 6.5° MCS). Within the time period of 100 years, the assumed the strongest probable earthquake is in the range $M = 3.5$ and for the time period of 50 years in $M = 3.0$. It was subsequently stated that the earthquake in this area is a rare phenomenon, and, in compliance with the analysis, there were no seismic issues preventing use of this area as a construction site for a nuclear power plant. According to the standards valid at that time, it was not needed to prepare special seismic analyses.

For Mochovce site, originally the report on seismic risk of EMO site of 1978 was used, confirming by a simplified probabilistic assessment, that the earthquake with intensity of 6° MSK 64 will not be exceeded with return period once per 10,000 years; acceleration on free field $PGA = 0.06 g$. The value was increased to 0.1 g

recommended as a minimum value (even currently) by the IAEA Safety Standards. Such value was used for completion of EMO 1,2 units.

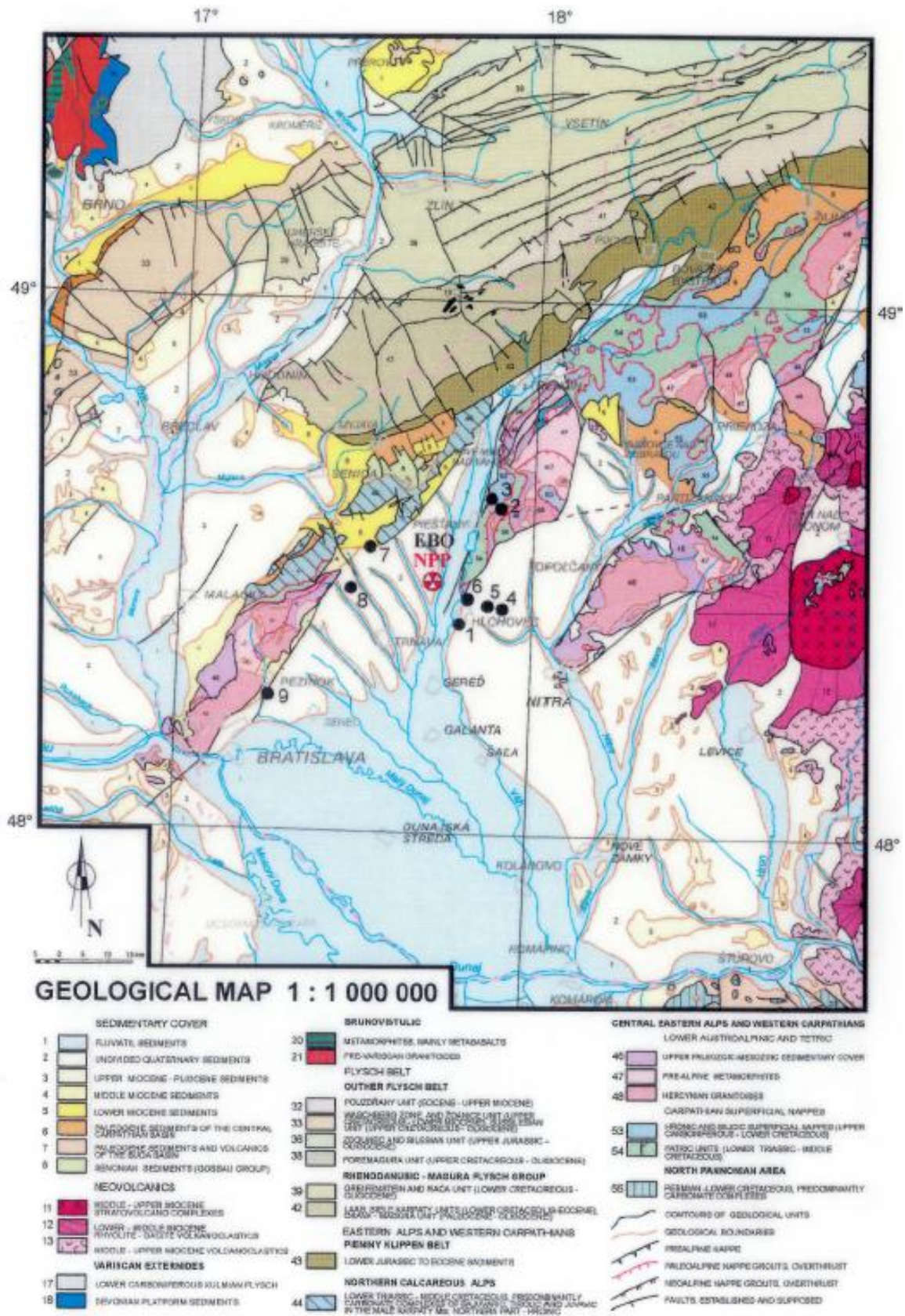

Figure 11: Geological map around NPPs in Slovakia

Taking into account the IAEA recommendations of 1998 and 2003, the UJD SR decided to increase the design-basis earthquake for Mochovce site with certain margin to $PGA = 0.15g$. This value is used for upgrading of EMO 1,2. For MO 3,4, based on the probabilistic seismic assessment the UJD SR specified the value $PGA=0.15 g$ as a design basis earthquake for the plant construction.

Conclusion on the adequacy of the design basis for the earthquake

Since 1980 till 2011, a number of different studies related to the seismic issues were elaborated for both sites in Slovakia ensuring that the current site assessment is performed in accordance with the current state-of-the-art knowledge.

EBO 3,4

Original plant design basis for the earthquake has been questioned since start up of the plant in 1986 and subsequently re-evaluated in several steps in accordance with development of methodologies, data and safety requirements. First step was the assessment of the seismic risk initiated by the Czechoslovak governmental commission in 1989. As a result of the work, the definition of the basic characteristics for the maximum design earthquake with the return period of 10,000 years and intensity of 8° MSK-64 was specified as $PGA = 0.25g$ in horizontal direction and $PGA = 0.13g$ in vertical direction. Validity of this specification was conditioned by installation of permanent monitoring of seismic phenomena by a network of stations in Male Karpaty region.

In 1997, the new Probabilistic Seismic Hazard Analysis for EBO site was prepared. The final report covered several components in compliance with IAEA recommendations as follows:

- formation of seismological database and geological database in wider region, close region, close vicinity and for the site itself;
- preparation of seismic-tectonic model;
- specification of attenuation for chosen soil movement characteristics;
- execution of the probabilistic calculation itself.

The analysis resulted in determination of ground response spectra RLE (Review Level Earthquake) for the entire EBO site with the following main characteristics:

- Probability of occurrence once per 10,000 years;
- Intensity 8° of MSK 64 scale;
- Maximal horizontal acceleration $PGA_{RLE-H} = 0.344 g$
- Maximal vertical acceleration $PGA_{RLE-V} = 0.214 g$
- Duration of decisive movements 10 s.

These new data were used for recent seismic upgrading of existing systems and for installation of new supporting structures.

The Figure 12 below illustrates development in time the EBO site specific hazard. Since the original design, in terms of the peak horizontal acceleration, the robustness of the plant has been increased about 14-times.

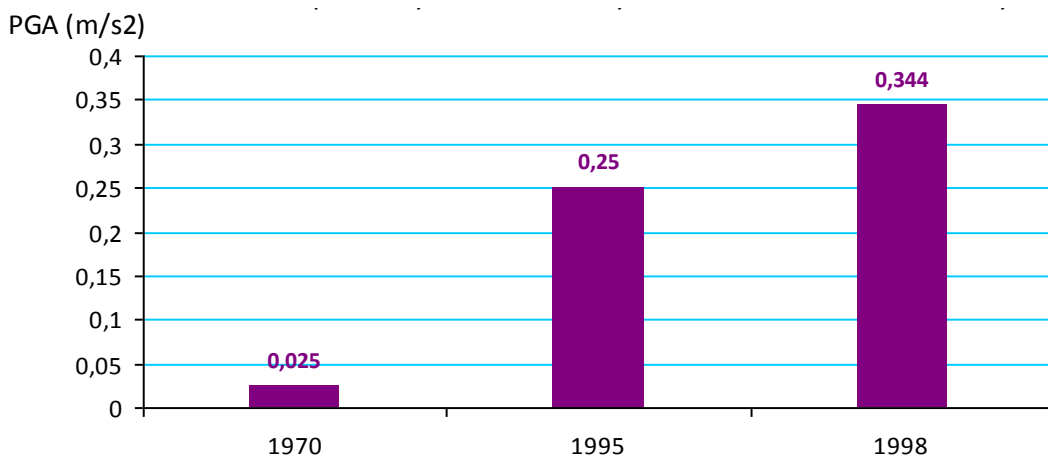

Figure 12: Gradual increase of EBO site seismic hazard

EMO

Following the decision on completion of EMO1,2, new assessment of the site seismic risk was made using deterministic approach, taking into account recommendations of the IAEA mission held in 1993. Based on this assessment, original design values (i.e. 6.5 - 7 MSK 64, acceleration of free field PGA = 0.06 g) were confirmed. However, recommendation of the IAEA Safety Guide No. 50-SG-S1 on minimum seismic resistance was accepted, with horizontal PGA= 0.1 g and the response spectrum from NUREG-0098 for bedrock. These input data were taken as a basis for the Technical Guide for Seismic Re-assessment Programme of the Mochovce NPP Units 1-4, prepared by IAEA in 1995. In 1996, the document “Requirements for Re-assessment of Seismic Resistance of EMO Units 1&2 Structures and Equipment” was prepared based on IAEA technical guide. This document, after positive confirmation by the UJD SR, became the fundamental document for EMO1,2 completion in the seismicity area.

After EMO1,2 commissioning, an IAEA mission took place in 1998, based on UJD SR invitation to verify seismic input data for EMO site. Based on recommendations of this mission, a detailed geological survey was performed in 1999-2003 aimed at identification of potential geological fractures in EMO region. The document “Probabilistic Analysis of Seismic Endangering of Mochovce NPP Site” was prepared in compliance with the IAEA Safety Guide NS-G-3.3 The document defined a new value for seismic level of the site, PGA = 0.143g according to the USNRC RG 1.165 (1997), with subsequent deaggregation of these values to the frequency of 10 Hz. The procedure of assessment and calculation methodology were verified and approved by the IAEA mission (SIDAM) in 2003. The probabilistic assessment resulted in determination of the seismicity levels for return periods of 475 years (SL1) and 10,000 years (SL2).

IAEA mission (SIDAM) in 2003 also recommended more detailed geological survey of Dobrica fracture that was identified as a potential active fracture. To document the aforementioned fracture stability or to prove its small depth, works documenting the fracture stability were made in 2006. In 2006, repeated measurements of shifts on the geodetic position net of the site were made in compliance with the IAEA mission recommendations, and in 2007 a sensitivity study of inclusion of fractures in the close Mochovce NPP region was prepared. Previous decisions regarding the seismicity level were not modified.

Taking into account the IAEA recommendations of 1998, 2003, the UJD SR decided to increase the design-basis earthquake for Mochovce site with certain margin to PGA = 0.15g (see Figure 13). This value is used for completion of MO 3,4 and also for currently ongoing upgrading of EMO1,2.

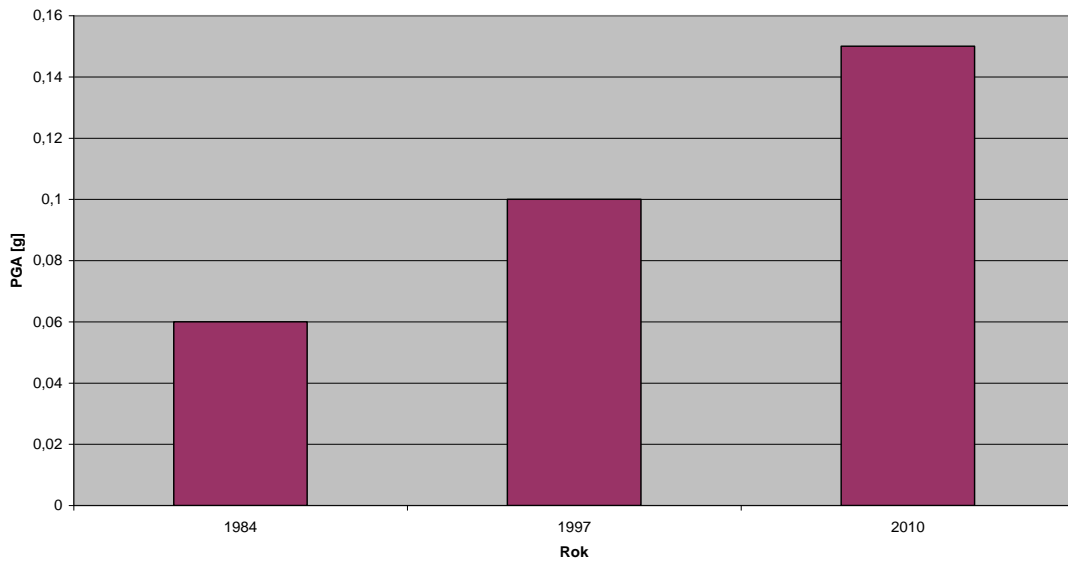

Figure 13: Gradual increase of EMO site seismic hazard

Legend: rok- year

For both sites (Bohunice and Mochovce), the seismic monitoring system has been implemented and is currently in use for early identification of any seismic activity potentially affecting the NPPs (see Figure 14). Features of monitoring of seismic activities and micro-activities of Bohunice and Mochovce NPPs include continuous recording and analysis of seismic events performed in 22 seismic stations. The seismic network of Bohunice NPP vicinity consists of 11 seismic stations in the following locations: EBO, Bukova, Dobra Voda, Hradiste, Lancar, Laksar, Katarinka, Pusta Ves, Plavecke Podhradie, Smolenice and Spacince. The seismic network of Mochovce NPP vicinity consists of 11 seismic stations in the following locations: EMO, Hrusov, Bory, Kolacno, Michalkova, Polichno, Mlynany, Hostie, Dlzin, Devicany, Valentova. Arrangement of Mochovce seismic stations was proposed and built based on detailed seismic and geological survey prepared by the Geophysical Institute of the Slovak Academy of Science and reviewed by IAEA missions in 1998 and 2004. The stations can be remotely controlled. Monitoring results are summarized in quarterly reports. In case of stronger seismic events of interest for the plant operation, the analysis results are prepared within two days from their recording. The seismic stations enable detection and localisation of local earthquakes with magnitude exceeding $MI > 1$. Seismic monitoring system is used for:

- Continuous monitoring of RB foundation plate vibrations,
- Automatic signal formation for the MCR, if specified acceleration value is exceeded (for EMO12 0.035g, for EBO 0.115g),
- Registration of vibration history when reaching pre-set acceleration value.

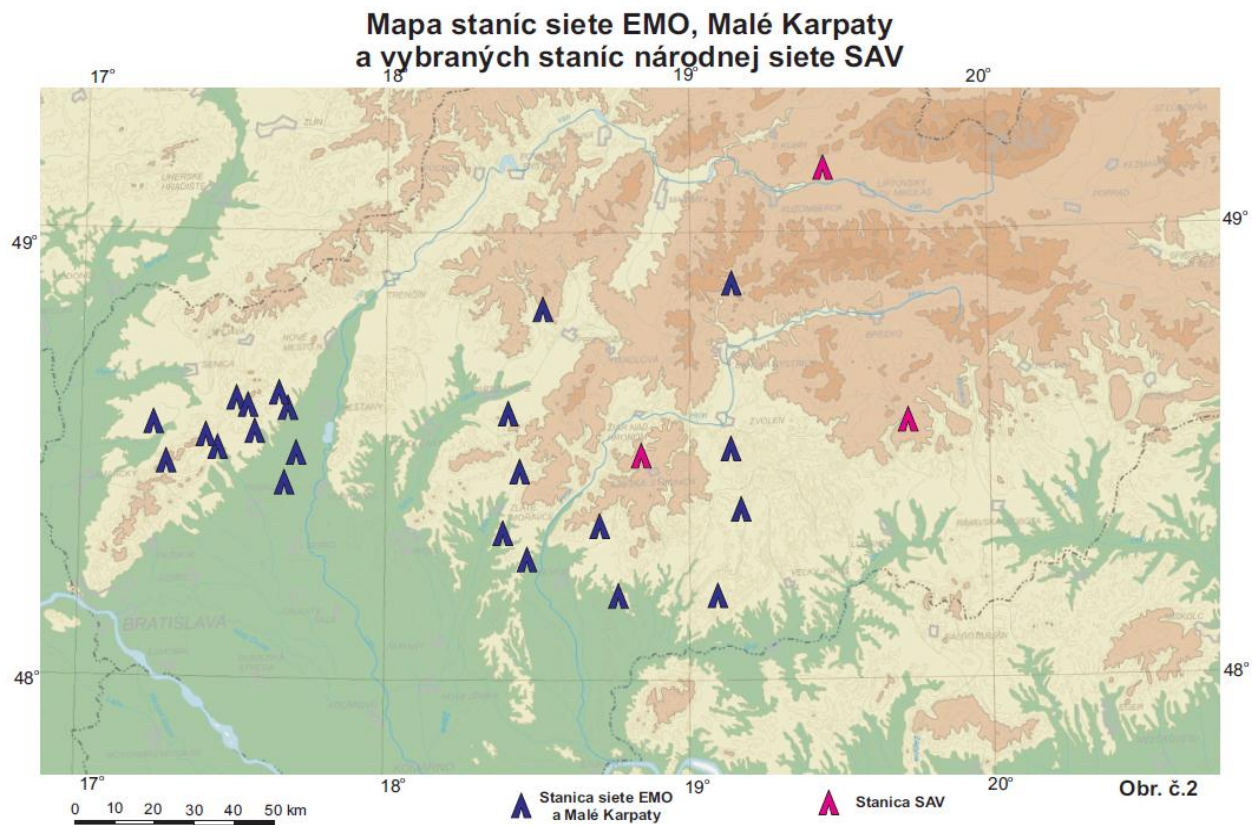

Figure 14: Arrangement of seismic monitoring stations in EBO and EMO areas

Legend:

Mapy staníc siete EMO, ... - Maps of EMO, Male Karpaty stations and selected stations of SAV national network

Stanica siete EMO ... - station of EMO and Male Karpaty network

Stanica SAV – SAV station.

2.1.2 Provisions to protect the plants against the design basis earthquake

2.1.2.1 Identification of most endangered SSC required for safe shutdown state

All structures, systems and components required for safe shutdown and residual heat removal after a seismic event and their classification into individual seismic categories are listed in the SSEL list (list of equipment for safe shutdown and cooldown following a seismic event). Individual systems, structures and components and their various configurations available for maintaining the safety functions were also briefly described in chapter 1, including information regarding their seismic resistance. Only systems seismically classified and having adequate seismic resistance were considered as available for performing safety functions following an earthquake, all other systems were assumed to be disabled.

For both operating plants the criteria for classification of individual components to seismic categories were used in accordance with the document “Technical Guidelines for the Re-Evaluation Programme of Mochovce NPP” (IAEA, 1996). The categories are as follows:

- Seismic category 1 includes civil structures, systems and components required for:
 - safe reactor shutdown, its maintaining in shut-down condition and residual heat removal and cooling down at least for 72 hours
 - integrity of the primary and secondary circuit up to the isolation valves

- prevention of radioactive releases into the environment
- Seismic category 2 includes all equipment not classified in seismic category 1. Seismic category 2 is divided to the following subcategories:
 - 2a containing civil structures, systems and components, which could, due to so called seismic interactions, directly or indirectly evoke loss of functionality, strength, leak-tightness and stability of position of structures, systems and components of equipment belonging to seismic category 1. Stability of position of structures and components is usually required to be preserved in this category during and after an earthquake.
 - 2b containing all other civil structures, systems and components of technological equipment.

Within the plant safety upgrading to newly defined site seismicity level (PGA=0.1, 0.15 or 0.344 g) all equipment included in the SSEL were re-evaluated using the Seismic Margin Assessment (SMA) method and upgraded to the required level, in accordance with the special methodology “Acceptance criteria and methodology for assessment of limiting (minimum) seismic resistance and for proposal of seismic modifications”.

Robustness of each component was determined by its HCLPF (which is also expression of the safety margin of a given component) using CDFM and GIP VVER method (EPRI NP-6041, IAEA-SSS No-28, IAEA-TECDOC-1333).

The main CDFM principles for calculation of the limiting seismic resistance (SMA) are as follows:

- Combination of effects of NPP operation loads and the earthquake
- Loading of material up to ultimate bearing capacity with minimal guaranteed values according to design standards
- Strength conditions corresponding to ultimate bearing capacity for concrete and steel structures, service level D for pressure components, pipes and vessels in accordance with ASME BPVC Section III
- Ductility – used for ductile mode of damage; for these cases, the factor usually ranges from 1.25 to 2.

The GIP VVER methodology also used for re-evaluation describes detection of seismic interactions and provides forms for recording of findings of seismic walk-downs together with correction methods. Accelerograms used for the upgrading were generated in accordance with NUREG/CR-0098. Special method was developed on assessment of stability and strength of anchors including the procedure for fulfilment of requirements and their verification.

No detailed collapse related analyses were performed for civil structures without seismic classification. Only requirements given in CSN 730036 were applied to these objects. However, in the assessment of the robustness of various equipment configurations all non-classified systems were assumed to fail in case of the design basis earthquake or beyond.

The following procedures are applicable for residual heat removal after an earthquake:

- Technological procedure for Anti-seismic protection system SISCOM
- Technological procedure for Residual heat removal after earthquake.

The procedures describe activities to be performed for the residual heat removal after a seismic event, including description of equipment and system interactions, operational limits and technological restrictions, attendance method and activities, system start-up and operation. The following conditions were specified for the “Scenario for safe unit conditions after a seismic event”:

- The main expected effects connected with vibrations induced in SSCs via the civil structures;

- Systems necessary for safe shutdown, residual heat removal and prevention of release of radioactive substances to the environment after a seismic event (listed in SSEL). This list includes also tanks with large water inventory that could worsen conditions due to their rupture or interaction.
- Electric components in switchboards are protected against water leaking from upper levels in the lengthwise electrical building by a protective cover.
- Seismic resistance of the systems is provided to the level SL2. Systems not designed as seismically resistant can be damaged.
- Seismic event is assumed to be connected with loss of power supply from external and internal sources, with a possibility of occurrence of local fires.
- Electric power supply of equipment listed in SSEL will be provided from EPS system categories I and II.

2.1.2.2 Main operating contingencies in case of damage that could be caused by an earthquake and could threaten achieving safe shutdown state

All potential affects which could threaten achieving safe shutdown state were taken into account, including:

- Potential failures of heavy structures; in order to prevent impermissible impact of failed operational equipment on seismic class 1 structures the situations with this possible interactions were evaluated. This evaluation was based on walk-down in rooms with installed safety equipment. Walk-downs focused on evaluation of operational equipment in given rooms and whether their failure caused by an earthquake could cause problems for any seismic category 1 equipment.
- Turbine damage could result in release of flying objects with high energy possibly impacting the lengthwise electrical building and then the reactor building. It was proven that earthquake with intensity 8° of MSK 64 scale will not result in damaging of rotating parts of turbo generators. Thanks to seismic design of the main turbine hall structures, the turbine and generator bearings and shafts are assumed to manage the seismic load. The over-speed turbine protection was justified to work safely even in case of its failure (fail-safe design) to prevent turbine damage caused by high speed in case of earthquake.
- High-energy piping rupture - in order to prevent pressure surges and flying fragments resulting from damaging large vessels, operational tanks with high-energy content in areas containing equipment of seismic class 1 were analysed and then reinforced to seismic category 2a to maintain their overall stability after an earthquake.
- *Fall of heavy handling equipment*: simultaneous operation of the crane with heavy load and earthquake is not assumed due to very low probability of such situation (only several operational hours of the crane / year). Seismic modifications proved that crane bridges installed in safety important buildings do not fall after an earthquake. Handling equipment in the reactor building installed above the containment top level, e.g. bridge cranes in the reactor hall or refuelling machine were analysed with regard to maintained stability during and after an earthquake.
- For seismic events, loss of external power supply was assumed, as evaluated in chapter5 of this report.
- For the earthquake of design basis level, the site can be affected by damage of access roads namely those close to assumed earthquake epicentre; access of staff and necessary technical means requires consideration of damage of power plant access points, as they weren't considered as seismically reinforced. These damages were considered in chapter 6 devoted to accident management.
- Availability of routes for potential transport of cooling water can also be affected.
- Occurrence of local fires induced by earthquakes should be and was considered.

2.1.2.3 Protection against indirect effects of the earthquake

The following measures were taken in order to prevent or mitigate the indirect effects of the earthquake:

- Operational equipment considered potentially risky is classified in seismic category 2a and its seismic resistance is proved considering the failure mechanisms, such as mechanical damaging, extensive flooding, incorrect function, etc., that must be eliminated.
- Civil structures located close to equipment important for safety were classified in seismic category 2a and then seismically reinforced to prevent their collapse due to seismicity. These are mainly:
 - Turbine hall directly connected with the lengthwise electrical building of RB; Stability of loaded main structures of the turbine hall is necessary not only to provide for stability of the reactor power block, but also to decrease possible extensive impact on equipment with higher risk potential installed inside the turbine hall,
 - Cooling towers with impact on ESCW CPS,
 - Operational building SO803,
 - Vent stack, since it is located nearby the reactor building.
- In order to prevent pressure surges and missiles resulting from damaged large vessels, operational tanks with high-energy content in areas containing equipment of seismic class 1 were analysed and then reinforced to seismic category 2a to maintain their overall stability after an earthquake. They include the following components:
 - HP- coolant purification system filter considering their possible impact on the containment integrity,
 - Feedwater tanks located in the lengthwise side electrical building.
- In order to prevent falling of heavy equipment, bridge cranes in the turbine hall and lengthwise electrical building (level +14.7m) have defined parking positions away from equipment (TG, steam and feedwater pipes and components) during unit operation at power.
- Access of fire brigades to individual important civil structures in case of fire is provided minimally from two directions and is defined in their intervention cards.
- Based on situation, cooling water pools can be supplied with cooling water from EBO hydrant network. This procedure was verified by non-standard tests.
- In case of destruction of the above source, water can be supplied from nearby water sources by shuttle transport, hoses or in a helicopter suspension sack. If the siding rail is not damaged, water can be transported in large volume railway cisterns.
- For Bohunice, Upper Dudvah can be considered as a potential source for shuttle traffic with access points in Pecenady, Zlkovce and Trakovice. Other possible sources include the creek Horna Blava and the pond in Jaslovske Bohunice, water reservoir Enviral in Leopoldov, the Vah channel in Drahovce and a water mill in Radosovce.
- The most suitable source for water pumping and subsequent supply to EBO is the dam Dolne Dubove. Its part next to the hatch is suitable for water extraction by a helicopter with suspension sack. This procedure was actually trained during an emergency drill (see the Figure 15).

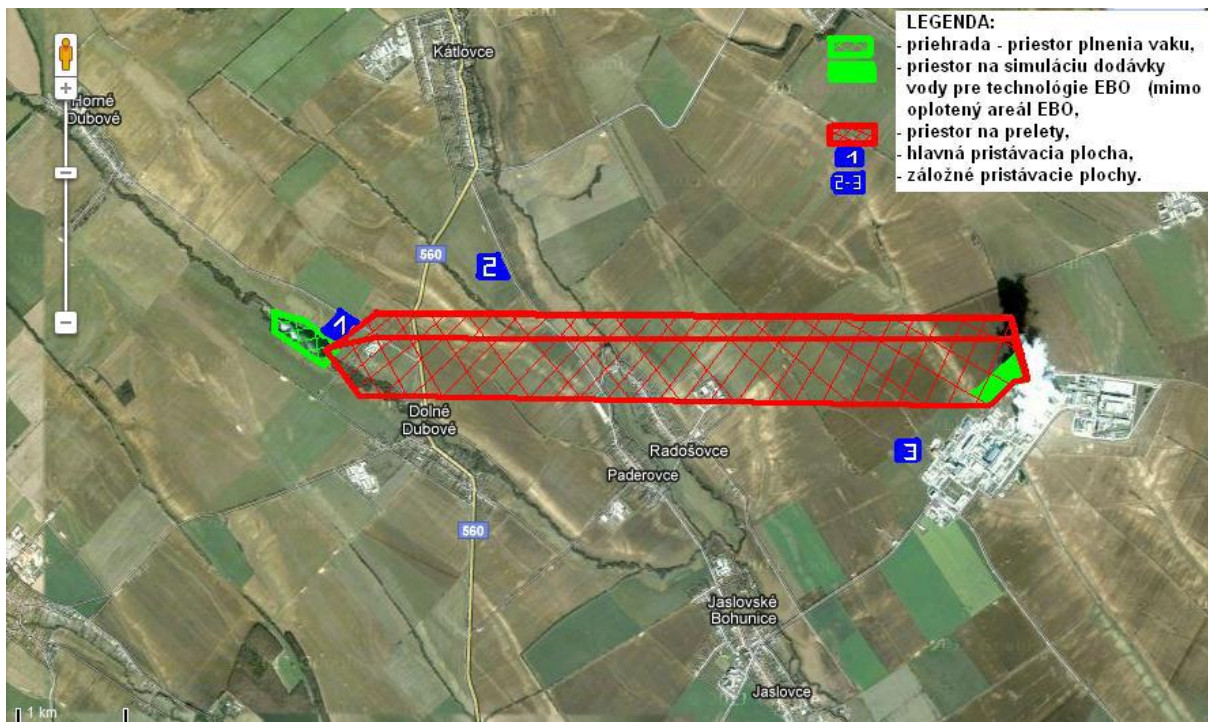

Figure 15: Working area for activities with the helicopter

Legend:

Priehrada ... - dam	– space for sack filling
Priestora na simuláciu ...	– area for water supply simulation for EBO technologies (out of EBO fenced area)
Priestor na prelety	– space for flyover
Hlavná pristávacia plocha	– main landing area
Záložné ...	– back-up landing areas

For Mochovce, provision of cooling water supply can be by fire fighting trucks from the water reservoir in Velke Kozmalovce. Access roads are from the state road Mochovce – Male Kozmalovce and then to the pumping station extraction point. There is no road bridge on the route that could be considered as an obstruction in case of a seismic event. As another water source a small hydro plant on the river Hron close to the village Kalnica (Kalna nad Hronom) can be used. There is no bridge on this route.

For Mochovce, staff access is assumed from the directions of Levice, Nitra, Zlate Moravce. The cities of Nitra and Zlate Moravce are available via the state roads and are assumed to remain available after defined seismic event. From the direction of Levice it is necessary to consider three road bridges on the river Hron within 10 km distance; thus, the river Hron is not going to limit arrival of specialized staff.

The following is considered for managing the local fires:

- Seismic and fire resistant fire-separating walls between individual fire sections,
- Seismic resistant HVAC fire dampers protected by fire insulation of HVAC ducts,
- Seismically resistant stable fire fighting system with seismically resistant EPS for fire identification and subsequent SFFE activation,
- Equipment containing flammables (namely oil) seismically classified,
- Extinguishing the fires by the plant fire brigade.

Equipment of EPS and VPS systems will be seismically reinforced regardless of whether they supply consumers included in the SSEL list or not, thus significantly decreasing the fire risk.

2.1.3 Compliance of the plants with its current licensing basis

2.1.3.1 Licensee's processes to ensure that plants SSC that are needed for achieving safe shutdown after earthquake, or that might cause indirect effects discussed under the previous section remain in operable conditions

Equipment in classified categories has individual quality assurance programmes subject to supervision by UJD SR. These programmes define inspection requirements for individual equipment since their commissioning. Inspections (revisions) are recorded in form of protocols. Besides these inspections, defined technological parameters are periodically evaluated in line with IAEA recommendations as part of controlled aging program for selected components and evaluation programme of civil structures. During the stress tests the plant walk-down was performed to verify the status of the equipment. It has been confirmed that all SSC is in compliance with its current licensing basis.

2.1.3.2 Licensee's processes to ensure that mobile equipment and supplies that are planned to be available after an earthquake are in continuous preparedness to be used

In order to maintain operability of mobile equipment designated for water delivery to the emergency feedwater make-up system, relevant pumps are prepared to deliver water from external sources in line with the time schedule for functional tests of RCS and SC equipment. In preparation of the stress tests and in response to WANO recommendations, selected mobile equipment and its capability to perform the required functions were tested.

2.1.3.3 Potential deviations from licensing basis and actions to address those deviations

In several safety upgrading steps, capability of the EBO3,4 units to maintain fundamental safety functions have been strongly increased from the original design basis PGA value 0.025 g (built as non-seismic design) through upgrading to PGA 0.25 g in 1995 up to the current value PGA=0.344 g, with corresponding upgrading completed in 2008.

For EBO3,4 no deviation from licensing basis regarding seismic resistance were identified. Seismic resistance of all relevant SSC was continuously increased based on regular reassessment of the site seismic risk.

Mochovce site was re-evaluated on the basis of a new methodology in period 1998 – 2003, and the new design basis earthquake value was set to PGA=0.143g with the return period of 10,000 years. Re-evaluation method was reviewed by an IAEA mission in 2003. In order to reach increased seismic safety margin, the power plant is currently being reinforced to PGA=0.15g. The same value was used for ongoing construction of MO 3,4 units.

2.2 Evaluation of safety margins

2.2.1 Range of earthquake leading to severe fuel damage

For mechanical and electrical equipment, the assessment and the upgrading was based on conservative approach considering elastic behaviour of the structures. Assessment of civil structures included, however, moderate structural inelastic behaviour of the structures. Taking into account properties of materials used for individual safety system components, first occurrence of plastic deformation should take place and only after

exceeding the structural limit values the component damage will take place. However, such assessment is beyond the current regulatory requirements and international standards, and the margin was not quantified yet. The evaluation of the seismic margins can only be obtained through refined elasto-plastic structural analyses. Work on the analyses has already started and the results are expected to be available early in 2012. Based on preliminary results, seismic safety margins of about 20-30 % are generally expected.

2.2.2 *Range of earthquake leading to loss of containment integrity*

The same assessment as made for the range to severe fuel damage is valid also for the containment. Consistently, the loss of containment integrity in EBO 3,4 is assumed not to occur below $PGA=0.35\text{ g}$, and in EMO not below 0.2 g .

2.2.3 *Earthquake exceeding the design basis earthquake for the plants and consequent flooding exceeding design basis flood*

Taking into account the site location, geomorphological and hydrological characteristics and in accordance with the analyses performed it was shown that even dam failures on the nearest rivers induced by an earthquake do not lead to flooding of the site. Structures for raw water supply installed on the rivers can be affected resulting in interruption of the raw water supply. The relevant issues are addressed as a loss of the ultimate heat sink event in chapter 5.

2.2.4 *Measures which can be envisaged to increase robustness of the plants against earthquakes*

Robustness of the plant against earthquakes has been significantly increased recently and it is considered adequate in accordance with the current requirements. Nevertheless, the following measures for quantification of margins and further improvements are envisaged:

- Quantification of margins of key SSCs for earthquakes beyond the design basis earthquake
- Development of seismic PSA
- Updating plans for logistic arrangement of transport to the NPP following an extreme earthquake.

3 Flooding

3.1 Design basis

3.1.1 Flooding against which the plants are designed

3.1.1.1 Characteristics of the design basis flood

Due to the inland location of both nuclear sites in Slovakia and a large distance from any major source of flooding, the design basis flood was not specified in the design documentation. However, potential sources of flooding, and in particular a strong rain, were postulated. The only credible cause of a large water intake, i.e. extreme precipitation, was specified and addressed in the plant structures and objects. The design basis rainfall set for EBO 3,4 was 65 l/s/ha, for all Mochovce units it was 140l/s/ha, in both cases with the duration of 15 minutes and a return period of 100 years. The largest values of precipitation typically take place in summer months, during strong storms.

However, within the stress tests, all other potential causes of flooding were evaluated, too. These included a potential for floods evoked by surface water sources, dam failures, ground water and extreme weather conditions, namely heavy rain, melting snow and combination of heavy rain and melting snow. A seismic event with subsequent internal floods was also considered. Evaluation of the floods which could impact the provision of the safety functions is provided below.

3.1.1.2 Methodology used to evaluate the design basis flood

Close surface water sources

Both sites are located far from significant surface water sources (rivers, large water areas).

The river Vah with the Slnava water reservoir is about 8 km far from the Bohunice site. Between the site and the river Vah, the lowland river Dudvah flows as the Vah right-bank affluent. The right-bank Dudvah effluents drain the area of the site. Between the site and the Jaslovske Bohunice village there is another small river Blava. The altitude difference of about 11 m in the east in a distance of about 3 km divides the site from the flat and in this part also sufficiently wide valley of the river Vah.

Mochovce site is located 5 km from the river Hron. The altitude of the Mochovce site is 233.10 – 242.10 m, while the top of the dam of the water storage reservoir Velke Kozmalovce on River Hron is at altitude 176.0 m, and maximum water level is at the altitude of 175.0 m.

Taking into account the distance from the rivers, the landscape and the elevation of the sites it can be concluded that the plant structures and the equipment inside the site cannot be directly endangered by floods from surrounding water flows and waterworks.

Failure of dams

The floods on the above mentioned rivers can affect operation of pumping stations located close to water reservoirs on the rivers and to interrupt the operation of the service water make-up systems.

Failure of dams on the river Vah could potentially affect the operation of EBO 3,4. In such case make-up water source in Drahovce (due to the failure of the pumps power supply) will be endangered and Peceny pumping station will be partially flooded when water level reaches 0.5 m (in the case of Oravska dam failure) or 1.2 m (in

the case of Liptovska Mara dam failure). In the case of the complete loss of water supply from Vah and Pecenady pumping station failure, the safety functions would be provided through usage of water inventory in cooling tower pools and in cooling water channels.

Rupture of existing dams in the River Hron basin does not pose a significant threat to the EMO1,2 and MO3,4 site considering their relatively small volumes and localization namely in the upper basin part. NPP structures are situated on a hillside. There are no dams in the vicinity that in the case of damaging (earthquake, intentional damage) could endanger the EMO1,2 and MO3,4 structures. If the Velke Kozmalovce water reservoir dam fails, the service water source will be endangered due to the flooding of the service water pumping station providing the service water to the Mochovce site. At the complete loss of the service water supply, water inventory in cooling tower pools and in cooling water channels will be used. At Mochovce site additional raw water reservoir is available and can be used.

The issues of the loss of service water are addressed within the scope of analysis related to the loss of heat sink. These issues are discussed separately in the chapter 5 of this report. However, the flooding hazard directly for the plant structures and equipment due to dam failures can be screened out.

Ground water

At the Bohunice site, the underground water level is situated in the depth of 16÷20 m. Underground water (activities and hydraulic regime) monitoring is made by means of the large network (143) of existing and newly constructed monitoring wells. The main objective of this monitoring system is mainly to ensure the protection of underground water sources against spreading of radioactive substances.

At the Mochovce site deep drilling works did not find any groundwater in the rock foundations. The analysis of geomorphologic, geologic, and hydrogeological conditions showed, that the groundwater cannot reach the NPP buildings foundations. Thus, the NPP does not have any permanent draining system for the control of the underground water level. Existing wells situated inside and outside the NPP site serve only for the dosimetric control of underground water.

It is therefore not necessary to neither consider effects of underground water on the stability of the civil structures nor consider this water as a potential source of flooding.

Extreme precipitation

Flooding due to a storm rain is normally prevented by the proper design of the rainwater draining (sewer) system.

Conservative estimate for EBO3,4 site area, the basis for the capacity of the draining system, is 18.2 ha. The 65 l/s/ha rain (5.85 mm in 15 minutes) corresponds to the total flow rate 1.18 m³/s, which is about 50 % of the capacity of the draining system (2.365 m³/s). The rainwater pipe system from the NPP site is led to settling reservoirs and from there to the Manivier stream. The settling reservoirs serve for catching of suspending substances and potential oil products from the site. In the case of extreme precipitations, the surface outflow from the highest situated area, which is the central pumping station, will be directed towards the lowest situated areas, which is the part of the site around settling reservoirs. It is seen that the capacity of the draining system has a large margin in comparison with the original design basis.

At the Mochovce site, the rainwater system collects and conveys water from different plant areas to the lowest point of the Mochovce site, located outside the plant boundary. The rainwater pipe system drains all rainwater to the single lowest situated place, where the rainwater pipe system settling reservoir is situated in the waste

water treatment plant. During the normal operation, the reservoir serves for catching of rainwater from flushing of areas from the Mochovce NPP site and serves as a safety element for catching of eventual leaks of oil products from the plant area. The topography of the site prevents accumulating of water at any level where the buildings with critical structures, systems and components are situated. The drainage system has independent piping for each of the platforms and the rainwater from each level is directly conveyed into the common reservoir which is shared by EMO1,2 and MO3,4.

The drainage system was designed taking into account a 15 min storm rain with a periodicity of 1 year and rain intensity of 140 l/s/ha. This rain intensity corresponds to a flow rate of 26.18 l/s in the smaller collector. The drained area of the smaller collector is 0.38 ha, of which 0.2 ha is hard surface (outflow coefficient 0.8) and 0.18 ha unpaved surface (outflow coefficient 0.15). The minimum size of the drainage system piping is DN300 and its capacity, with a slope of 2%, is 147.07 l/s. The rainfall on the same drained area which could origin such flow rate corresponds to almost 70 mm of precipitation with duration of 15 min, which is almost double of the one with 100 year return period.

The margin is 38 mm with reference to the 100 year return period precipitation with duration of 15 min.

The extreme precipitation values were assessed in the report prepared recently (in 2011) by the Slovak Hydro-meteorological Institute for the Mochovce site, in connection with MO3,4 construction. For the assessment of maximum rainfall/snowfall values, 30-years of annual measurements from Mochovce meteorological station were used (1981-2010), as well as values of up to the 65-year time series of annual values of highest rainfall intensities at Mochovce and historical time series of rainfall intensities in Slovakia. The assessment was done by extrapolations using DDF (Depth Duration Frequency) curves. The main results of the study are summarized in the following table of recommended extreme values of meteorological parameters to be used for safety assessments:

Meteorological parameter	Return period		
	unit	100 years	10 000 years
Inventory of water in the snow layer	mm	88.4	165.8
Extreme snow and precipitation	mm	120.6	224.4
Storm rainfall intensity with duration of 300 min.	mm/min	0.226	0.389
Storm rainfall intensity with duration of 30 min.	mm/min	1.379	2.330
Storm rainfall intensity with duration of 15 min.	mm/min	2.133	4.067
Maximum daily height of water layer from melting of snow	mm	50	100

Common part of the sewer system for both EMO1,2 and MO3,4 collect rain water from 33.12 ha and its capacity is 5.9 m³/s. The capacity is sufficient for draining of the whole site, even if all the rain water would be collected by the sewer system (not the case).

From the table it can be seen, that the value of 140 l/s/ha used in the design basis of EMO is significantly lower (~12.6 mm) than predicted in the new study. Similar meteorological study for Bohunice site as already developed for Mochovce is also under preparation in order to update the original design values, with the completion date in January 2012. The study will also include methodology for the assessment of the maximum water level on the site for extreme precipitation. It is expected that more substantial difference in comparison with EMO3,4 design value of 65 l/s/ha can be estimated and capacity of the drainage system can be questioned. Of course it does not mean that short intensive rain beyond the design value will result in site flooding. In

particular, not full amount of raining water should be immediately drained, it can be done with certain delay. It is expected that in the case of correct functioning of the drainage system there is no risk of any significant site flooding. However, this expectation should be confirmed after finalization of the new meteorological study by more detailed assessment.

Nevertheless, in order to be on the conservative side, despite of the fact that the proper functioning of the sewer system excludes the possibility of flooding by the strong rainfall, the behavior of the plants in case of complete loss (clogging) of the drainage system was also analyzed. It was conservatively considered that the extreme rainfalls can cause inoperability of sewer system inlets by deposits released from non-hardened areas and that the water gradually flows along the structures to the lowest places. In such case, certain water level above the ground can be established around the civil structures of the plant.

Estimation of the water level under conditions described above is quite complicated task. Using the table above, considering both extreme rain and snow melting and taking into account the shape of the terrain it was estimated, that temporary flooding height with return period 10,000 years will not exceed 10 cm.

Internal floods caused by an earthquake

In addition to external sources of flooding, vulnerability of all buildings containing electrical equipment potentially affected by flooding (reactor building and auxiliary building, turbine hall, lengthwise and transversal electrical building, diesel generator stations, essential service water station, emergency feedwater system building), internal floods (caused by ruptures of pipes/tanks) were assessed considering the rupture of the most vulnerable water pipelines following an earthquake.

The following sources of internal flooding were considered for the both EBO3,4 and EMO1,2:

- Large break of the feedwater pipeline in the lengthwise electrical building,
- Large break of circulating cooling water system in the turbine hall,
- Large break of feedwater pipeline and condensate pipeline in the turbine hall.

From flooding point of view, the worst case is the large break of the circulating cooling water pipeline, potentially releasing up to 85 100 m³ of water (the value is given for MO3,4, for EBO 3,4 the equivalent value is 52 000 m³). Damage of this seismically not classified pipeline in the turbine hall can be considered as the most serious consequence of the earthquake. However, the analysis has shown that even in the case of release of the complete volume of water the cable channels, located in the turbine hall basement with manholes situated at - 3.0 m that could cause spreading of the flood to the adjacent electrical building, will not be endangered.

In addition, in the case of EMO1,2, the flood caused by the make-up water storage tank damage (2x6000 m³) was considered. The make-up water storage tank is located outside the EMO1,2 site, about 300 m in north-eastern direction towards the wastewater treatment plant. Wastewater is transported from the storage tank to the chemical water treatment (CWT) plant via two pipelines of 1,200 mm diameter and length approx. 550 m. The chemical water treatment plant is located directly in the NPP site, and the elevation difference between the chemical water treatment and the make-up water storage tank is about 17 m. The NPP site is separated from the make-up water storage tank with 2.6 m high concrete wall. The terrain slopes towards a ditch with depth from 3 to 5m in front of this wall in direction to the make-up water storage tank. Water level in the tanks 2 x 6,000 m³ is checked remotely via sensors from pumping station on the River Hron. In the case of a potential damage of the tanks and under the assumption of release of the whole make-up water volume, i.e. 12,000 m³, the NPP site flooding is not possible.

3.1.1.3 Conclusion on the adequacy of protection against external flooding

As explained above, no protection against external sources of the site flooding is needed, except adequately designed capacity and ensured operability of the sewer system in order to cope with the extreme precipitation. The systems have been designed for the original design basis precipitation (storm rain) with large margins. Updated meteorological studies however indicate that initial design basis for maximum precipitation might be reconsidered. This reconsideration has been already taken into account in implementing upgraded design measures against entering of water into the safety important buildings.

3.1.2 Provisions to protect the plants against the design basis flood

3.1.2.1 Identification of systems, structures and components (SSC) that are required for achieving and maintaining safe shutdown state and are most endangered when flood is increasing

Vulnerability to flooding differs for different types of structures, systems and components, namely for civil structures, mechanical components, electrical and I&C components.

Since the impact of the ground water has been screened out, the event of flooding in general is not endangering the civil structures: no consequences of flooding on civil structures are expected, but only consequences to technological equipment installed therein. The analysis is significant only for the civil structures housing safety significant structures, systems and components and whose ground floor is at the lowest absolute elevation, which is then evaluated as the most vulnerable one in the stress tests analyses. The vulnerability is evaluated by progressively increasing water level, starting from the lowest site elevation.

In the internal flooding analysis it is assumed that:

- if flooding reaches the elevation of the room in which an active component is installed, such component is lost unless hydraulic guards are available;
- if flooding reaches the elevation of the floor of the room in which electrical equipment ensuring power to an active component is installed, such component is lost unless hydraulic guards are available;
- safety-related I&C cabinets and MCR/ECR panels are installed at sufficiently high level; for this reason, it is assumed that no loss of active components due to the loss of safety-related I&C control can be induced by flooding.

If needed, as a second step, it is evaluated whether refined considerations (e.g. analysis of the precise elevation of a component within the room) are needed. Cables and passive components (e.g. piping) have a significant resistance against flooding and hence have not been further taken into account in the analyses.

The buildings of the plants requiring detailed assessment of vulnerability to flooding are:

- Reactor building and auxiliary building, where the electric drives of the emergency injection pumps and auxiliary feedwater pumps are located,
- Turbine hall, longitudinal and transversal electrical buildings, where electric switchboards and power supply automats could be affected,
- DG station, with 6 kV outlets, after exceeding certain level, water penetrating mainly through untight gates on the northern side of the object will run to the areas under DG, where it can flood 6kV outlets in case of further increased level,
- Pumping station with ESCW pumps and firewater pumps,

- Emergency feedwater system building; elevated level water could rise up to the EFWP drive levels,
- Emergency response center,
- Power cable ducts.

3.1.2.2 Main design and construction provisions to prevent flood impact to the plants

Due to the fact that the only possibility for the site flooding in Slovakia is extreme precipitation, the main way of prevention is adequately designed and maintained sewer system. If in spite of this measure a failure of the system is postulated, proper sealing of the buildings and elevated access doors to the building is the adequate design provision. The current situation in this matter is described below.

In EMO1,2 and MO3,4 design, the elevated access (20 cm above the ground) have been considered for safety-related buildings housing safety equipment i.e.:

- diesel generator station,
- reactor building,
- longitudinal and transversal electrical building,
- essential service water (ESCW) pumping station.

In fact, as far as reactor building, longitudinal/transversal electrical buildings and diesel generator station are concerned, such buildings have either hermetic doors and minimum access thresholds of 20 cm to the rooms housing safety-related equipment (reactor building) or have a 20-cm access threshold (diesel generator station and longitudinal/transversal electrical buildings). Sensitive components in the essential service water station are the electric motors of the ESCW pumps, which are placed 60 cm above the ground level. Taking into account that electric cable functionality is not affected by flooding, the damage to the pumps occurs when the water reaches the 60-cm height above the ground level.

In EBO3,4 units which were designed earlier, less attention was originally paid to the protection against flooding due to extreme precipitation. The relatively vulnerable buildings of the plant are:

- Reactor building, where emergency core cooling system pumps and spray pumps are located (at -6.5 m elevation),
- DG station, with 6 kV outlets,
- Longitudinal and transversal electrical building,
- Chemical water treatment plant with EFWP,
- Emergency response centre.

A very conservative calculation model was prepared for quantification of time margins and assumption of flooding duration for the calculation of endangering of the emergency pumps installed in the reactor building basement. Based on this model, the pumps could be under risk only after more than 72 hours of flooding resulting in constant water level at 10cm (i.e. conservatively not taking into account any active countermeasures and the natural draining profile of the site) – see the Figure 16.

There are two drainage pumps (each 25 m³/hr) installed in the reactor building for pumping water out of the rooms in the case of internal flooding. However, capacity of the pumps, even considering all mobile pumps available for the fire brigade on the site (altogether 216 m³/hr) is not sufficient for adequate removal of water under such severe assumptions. Therefore, measures aimed at the prevention of water inflow into the building were necessary.

Detailed analysis showed that the site flooding with the water level more than 30 cm combined with the loss of all sources of external power supply could result in station blackout scenario but not sooner than in 24 hours, due to flooding of busbars in the electrical building and unavailability of DGs. Provision of safety functions (heat removal both from the core as well as from the spent fuel pool, in particular) for SBO scenario is thoroughly analysed in the chapter 5.

However, in the case of combination of flooding and loss of all sources of external power supply and no countermeasure taken, the availability of DGs is vital. The vulnerability of DG station to flooding can be assumed above about 20 cm of constant level of water around the DG building (this very conservative assumption has to be confirmed by planned detailed topological study of natural drainage characteristics of the site). It is assumed

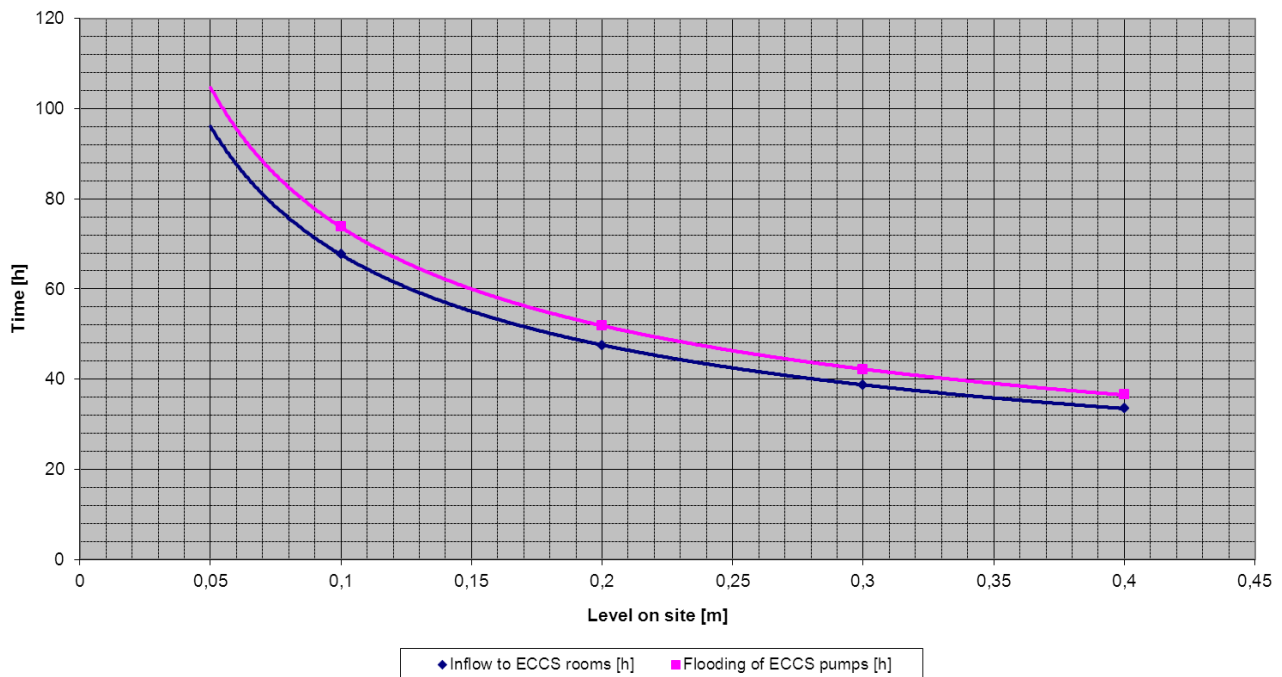

Figure 16: Prediction of time margins to endangering of emergency pumps by flooding

that the underground situated DGs power outlet could be disabled within 1-2 hours of constant flooding. This would result in the station blackout scenario. Provision of safety functions (heat removal both from the core as well as from the spent fuel pool, in particular) in SBO can be found in the chapter 5.

Based on the analysis, certain improvements were promptly implemented during the period of stress tests. In particular, sand bags were prepared as a temporary passive protection which can be placed in front of the gates into the reactor building and DG station. Final solution with permanent passive protection is in the pre-design stage (need to consider transportation needs during maintenance period). The walk-down and measurements of position of doors and gates performed in October 2011 led to the following conclusions which need to be proved by above mentioned planned analyses:

- Entrance to the reactor building is increased by ~10 cm above the ground level, i.e. flooding with return period of more than 10,000 years would be necessary to allow inflow of water into the reactor building.
- External flooding water level near the DG station should be ~20 cm in order to allow water inflow to the room with 6 kV power outlet, which is significantly higher than the possible flooding level due to the drainage characteristics of the site.

Sufficient protection of components of the safety systems against internal flooding caused by ruptures of the pipelines and tanks is ensured:

- By designed redundancy of safety systems and their components;
- By their own protection cover resistant to humidity and increased temperature or by technological design of the component itself;
- By its position in a sufficient height to have the maximum water level resulting from the conservative calculation below the level of these components;
- By possibility to drain water leaking to the room floor;
- By periodical inspections made by operators, who can close valves in some pipes (not critical for safety) by manual manipulation from corridors, thus stopping the fluid leaks.

Based on the analysis it was concluded that configurations with three redundant safety systems in the plants are resistant against internal floods. Various measures implemented before the stress tests in order to limit consequences of internal flooding (e.g. improved sealing between compartments, provisions of water draining, modified layout to set-up proper inclination for water pathways) were taken into account in the analysis.

3.1.2.3 Main operating provisions to prevent flood impact to the plants

Operating provisions include

- Procedures for maintaining operability of rainwater, industrial and sanitary sewer system,
- Procedures for the fire brigade for pumping water out of the flooded areas.

3.1.2.4 Situation outside the plants, including preventing or delaying access of personnel and equipment to the site

During floods evoked by surrounding water streams and waterworks, road in the river Vah basin will be affected and it will be necessary to adopt and manage measures based on decisions of state administration and local self-administration authorities. It is assumed that Piestany town will be evacuated and the relevant connecting roads near Zlkovce, Leopoldov, Hlohovec, Cervenik, Madunice and Drahovce will be unusable. However, accessibility of the Bohunice site through the roads J. Bohunice – Trnava, Malzenice – Trnava and Velke Kostolany – Vrbove will be without any limitation.

In order to maintain raw water supplies, it will be necessary to transport personnel for operation or inspection and potential repair of equipment in the Drahovce intake structure and in pumping station Pecenady. Sources and commodities needed for assurance of life needs of staff and operation of SSCs will be provided by roads through areas not affected by flooding. Potable water distribution will remain functional.

Access roads to the Mochovce site are not vulnerable to major flooding and there should be no problems with access to the site.

In more complex situations the sources, commodities and assistance needed for assurance of life needs of staff and operation of structures, systems and components, including potable water, will be provided in a manner described for both sites in chapter 2 in case of earthquake.

3.1.3 Plants compliance with its current licensing basis

3.1.3.1 Licensee's processes to ensure that plants systems, structures, and components that are needed for achieving and maintaining the safe shutdown state, as well as systems and structures designed for flood protection remain in operable condition

External flooding was not postulated within the original design basis of EBO3,4 and EMO1,2. External flooding has been included in the plant design basis and therefore properly taken into account in the design of MO3,4. As it was explained above, plant civil structures where safety important systems and components are located is adequately protected including newly conservatively estimated level of potential external flooding. Administrative procedures and processes to ensure the availability of systems and components needed to cope with flooding scenarios are available and will be further improved.

3.1.3.2 Licensee's processes to ensure that mobile equipment and supplies that are planned for use in connection with flooding are in continuous preparedness to be used

There are several mobile pumps available in both sites for the fire brigades and purchasing of additional pumps is planned. For example, in Bohunice existing equipment include:

- 1 floating pump FROGGY with capacity 800l/min; own petrol engine
- 1 floating pump SAW 200 with capacity 800l/min; own petrol engine
- 4 submersible electric pumps MAST T12 (capacity 1,200l/min each), 380V
- 1 submersible pump SIGMA KDFU 80, capacity 800l/min, 380V.

Operability of the pumps was tested during special tests following the Fukushima accident.

Regular maintenance/inspection programmes of mobile equipment intended to be used in a flooding scenarios are in place for EBO3,4 and EMO1,2 and will be developed in MO3,4 before commissioning. Pump maintenance follows relevant technical documentation.

3.1.3.3 Potential deviations from licensing basis and actions to address those deviations

Plants are in compliance with the original licensing basis and actions have been taken to strengthen their level of protection in order to cope with newly defined external threats of flooding. Based on the new meteorological data already available for Mochovce site and under development for Bohunice site it seems appropriate to reconsider the original design basis accordingly.

3.2 Evaluation of safety margins

3.2.1 Estimation of safety margin against flooding

Only extreme precipitation can be considered in Slovakia as a potential source of flooding.

In the safety report for EMO1,2 it is stated that in the case of strong rain with a return period 10,000 years and a duration of 300 minutes, assuming complete blockage of sewer system and no staff action to recover it, the water level flowing around the civil structures could reach maximum height 74 mm. This value has been taken as very conservative also for MO3,4. The value is nearly 3-times higher than the very conservative estimate of the flooding level, since water could affect safety systems only if water level would exceed 20 cm.

In Bohunice, the protection is less robust than in Mochovce, but taking into account the temporary measures taken (permanent passive protection being prepared), the margins are also sufficient, capable to protect important plant structures, systems and components against extreme rain with a return period of 10,000 years.

It should be underlined again that previous description corresponds to combination of extreme precipitation, failed rainwater pipe system and no corrective measures taken by the staff, namely sealing gaps in doors and gates. In addition, flooding due to the extreme precipitation will be limited in time.

3.2.2 Measures which can be envisaged to increase robustness of the plants against flooding

In spite of the extremely low probability of site flooding and measures already available, additional provisions are considered to further increase safety level of the plants as follows:

- To finalize a new meteorological study for Bohunice site including recommended extreme values of meteorological parameters to be used for safety assessments and methodology for determination of maximum possible site flooding due to extreme precipitation
- To update the Preoperational Safety Analysis Reports for both EBO3,4 and EMO1,2 for internal and external hazards taking into account updated meteorological data, plant improvements and state of the art methodology
- To update procedures for maintaining operability of rainwater, industrial and sanitary sewer system
- To update procedures for recovery of serviceability of affected plant systems and components following an internal flooding, including activities of operating staff and firemen
- To purchase manually portable submersible pumps with possibility of fire hoses connection
- To purchase portable gasoline/diesel pump
- To install permanent provisions against penetration of water into safety important buildings in the case of flooding in Bohunice site.

4 Extreme weather conditions

4.1 Design basis

4.1.1 Reassessment of weather conditions used as design basis

4.1.1.1 Verification of weather conditions that were used as design basis for various plants systems, structures and components: maximum temperature, minimum temperature, various types of storms, heavy rainfall, high winds, etc.

This section of the report deals with weather conditions used for design basis: extreme wind, extreme temperatures and humidity, extreme snow amount, extreme freeze and icing, and their combinations. The extreme rainfall, storm, and floods were discussed in the previous Chapter 3 of the report.

Information on the weather conditions at the site of the Bohunice and Mochovce nuclear power plants is summarised in the design documentation, safety reports and their supportive documentation. An overview of the weather conditions is given in the stress test reports from particular plants. The provided information is processed in the context of the IAEA documents, which set out the requirements, conditions and procedures for compliance with the safety criteria. The summarisation uses:

- Meteorological data from off-site sources, i.e. data from the meteorological stations collected for a long period of time under conditions determined by the World Meteorological Organisation (WMO);
- Data from on-site meteorological program implemented for the measurement of site specific data and dispersion of radioactive substances in the air and water.

The on-site meteorological data for Bohunice site are available from 1961, and for Mochovce site from 1981. The off-site meteorological data are recorded and stored in the databases of Slovak Hydro-meteorological Institute (hereinafter "SHMI") and other relevant documents.

Following the on-site and off-site measurements of meteorological stations an absolute maximum temperature of climate normal for Bohunice (38°C) has been taken. The absolute maximum air temperature was reached 38°C on 18 July 2007. The absolute minimum air temperature reached -26.1°C on 13 January 1987, which is not far away from an absolute temperature minimum of climate normal for Bohunice (-30°C).

Data from meteorological observations for the period from the beginning of the 80th years up to the present, are in the global but also in regional climate characterized by the increased dynamism to its warming. Such changes are accompanied by a smaller or greater incidence of extreme changes of climate characteristics of the meteorological phenomena.

According to the results of the Intergovernmental Panel on climate change it may be in the time span of several decades to expect clear manifestations of climate change in the Central European region. In view of the expected lifetime of the nuclear power plants in Slovakia, the utility adopted necessary measures to continue in the meteorological measurements and evaluation of data received on nuclear power plant sites. These data will be used in the near future for assessing and predicting the consequences of climate change to the operation of nuclear power plants and for the eventual future review of meteorological and hydrological characteristics of the sites.

In 2011 SHMI produced a study for Mochovce nuclear power plants, which deals with the general climatological evaluation of the Mochovce site, as well as evaluation of the meteorological variables (the extreme rainfall,

extreme snow amount, extreme wind, extreme air temperature and humidity, extreme frost and icing, and the minimum and maximum flow rates in the neighbouring major rivers). The study was processed within the meaning of the procedures for the evaluation of the extremes and climatological procedures according to the IAEA recommendations. Results of the study were also used for the reassessment of weather conditions applied for design basis.

Similar study for the Bohunice site, as already developed for the Mochovce site, is under preparation, in order to update the original design values for weather conditions, with the completion date in January 2012.

After the last verification and completion, the weather conditions used for current design basis of Bohunice and Mochovce nuclear power plants are actualised. Specifications are provided in the design documentation, safety reports and referenced documents.

4.1.1.2 Postulation of proper specifications for extreme weather conditions if not included in the original design basis

Hurricanes and tornados were originally excluded for the Bohunice and Mochovce sites and thus not included in the design. However, on the basis of current meteorological studies, tornados should be considered. The updated analysis of the threats show that only credible rotating winds for the Bohunice and Mochovce sites are those associated with the tornado categories F0 and F1 of Fujita scale. Now, the tornados are added to the actualised plant design and evaluated.

4.1.1.3 Assessment of the expected frequency of the originally postulated or the redefined design basis conditions

Assessment and specifications of extreme weather conditions relevant for the Bohunice and Mochovce sites are contained in the design documentation, safety reports, studies and their referenced supportive documentation. An overview of results from the assessments is provided in the utility reports.

Due to the vicinity of Bohunice and Mochovce sites (80 km distance) and the similar climatic conditions of the sites, the expected intensities and frequencies are foreseen to be the same for extreme meteorological conditions (temperature and humidity, snow amount, icing, wind, etc.) and their combinations.

Characteristics of some meteorological variables are listed in the table below. A summary of the site relevant meteorological variables and their characteristics including frequencies can be found in the plant safety reports and their referenced documentation. Complete information is given in the source document "Summary Report of Slovak Hydro-meteorological Institute for Mochovce Site, 2011".

Characteristics of meteorological variables – temperatures

Meteorological variable	Likelihood of adhering to the		
	Unit	100 years	10 000 years
Absolute maximum of yearly air temperature	°C	+38.7	+43.2
Absolute minimum of yearly air temperature	°C	-31.5	-47.4
Maximum temperature lasting 6 hours	°C	+37.5	+41.6
Minimum temperature lasting 6 hours	°C	-23.0	-33.7
Maximum temperature lasting 7 days	°C	+29.0	+33.5
Minimum temperature lasting 7 days	°C	-17.2	-27.3

Meteorological variable	Return period		
	Unit	100 years	10 000 years
Maximum snow amount	cm	81	123

A summary on the assessment of scope, intensities and frequencies of the originally postulated or the redefined design basis weather conditions are provided in the stress test reports. The assessment also includes a comparison of current design basis for extreme weather conditions with IAEA recommendations, European Utility Requirements (hereinafter “EUR”), and relevant STN EN standards.

In general, specifications of extreme weather conditions for Mochovce site are in compliance with IAEA recommendations, European Utility Requirements and relevant STN EN standards. However, as mentioned before, the Bohunice nuclear power plant has to finalize the update of assessment of site weather characteristics, which is near completion, to take into account recent knowledge of meteorological conditions.

4.1.1.4 Consideration of potential combination of weather conditions

In the design basis, the loads of following combinations of extreme weather conditions are considered to be most severe for safety of both nuclear power plants Bohunice and Mochovce:

- Wind/snow and icing, and
- High atmospheric temperatures and long-term deficit of precipitations.

To assess the combination of wind/snow and icing loads the values based on STN EN 1991 standard for electrical equipment are used in design and plant safety evaluations. For return period of 100 years the wind speed is considered 27.2 m/s and icing thickness is 29 cm; for return period of 10 000 years the considered wind speed is 38.7 m/s and icing thickness is 38 cm.

Characteristic feature of the extreme drought from the point view of its consequences on nuclear power plant is that the extreme drought is not a dynamic change but a long progressive process, where there is enough time for the implementation of specific foreseen safety measures. So, the considered extreme drought should not endanger safety of the plants. The situation with loss of water intake is solved in plant operational procedures.

4.1.1.5 Conclusion on the adequacy of protection against extreme weather conditions

The protection of the nuclear power plants against extreme weather conditions is described in the plant documentation and utility reports. The defence in depth concept is applied for the design of Bohunice and Mochovce nuclear power plants. It consists of multiple physical barriers and set levels of protection. In general, safety systems are designed as redundant, independent, diverse, and physically separated. In addition to the design features, the plants have qualified staff, operational procedures and arrangements to avoid, manage and mitigate the events, if occurred.

The utility evaluated weather conditions used as design basis. All weather conditions and their combinations important for the Bohunice and Mochovce sites are considered. The evaluation follows procedures and guidance provided in the relevant IAEA documents. It uses on-site as well as off-site data from standard meteorological measurements and observations, data processing, extrapolations, prognosis, expert judgements, and conclusions.

Postulated external events and their characteristics caused by extreme meteorological conditions are considered complete and specified in line with international practice. Originally postulated events were extended by tornadoes. Evaluated meteorological phenomena and their combinations include extreme temperatures and humidity, drought, snow and icing, direct and rotating wind. Specifications of the events are estimated for up to the 10,000 year return period.

The evaluations and also the experience gained with the operation of Bohunice NPP at the maximum/ minimum values of temperature nearly at a level of their 100 year extreme values have demonstrated resilience and stability of Bohunice plant service during the real meteorological extremes, what is to be expected for Mochovce nuclear power plants because of the proximity of the plant design.

The protection of plants against extreme weather conditions is considered to be adequate. Provided evidences show that considered extreme weather conditions should not endanger the safety of the Mochovce nuclear power plants and Bohunice nuclear power plant.

Results of analyses and evaluation of safety margins as well as measures, which can be envisaged to increase robustness of the plants and/ or safety demonstration against the extreme weather conditions are summarised in the following chapter of this report.

4.2 Evaluation of safety margins

4.2.1 Estimation of safety margin against extreme weather conditions

4.2.1.1 Analysis of potential impact of different extreme weather conditions to the reliable operation of the safety systems, which are essential for heat transfer from the reactor and the spent fuel to ultimate heat sink

Analyses of potential impact of different extreme weather conditions to the plant safety and reliable operation of the safety systems are documented in supportive documents referenced in design documentation, safety reports, and documentation elaborated in the frame of safety evaluation and safety upgrading programmes of the plants. The scope of the analyses, depth of the analyses and their quality in regard to the current requirements on safety analyses varies from plant to plant. More complex analyses and evidences of the plant response to extreme weather conditions are elaborated for the MO3,4 nuclear power plant which is under construction. Ability of logistical arrangements, transport of resources and connections necessary for ensuring the needs of staff were also evaluated. Results of analyses and evaluations are summarised in the particular utility report.

The evaluation of the impact of extreme meteorological conditions of beyond design basis accidents to the safety important systems, structures and components of EBO3,4 and EMO1,2 nuclear power plants strikes on the lack of information in the current plant documentation. Therefore, the missing information for the stress test analyses has been conservatively adopted from newly drawn up documentation for MO3,4 nuclear power plant. This is considered to be acceptable because of similar design, plant site characteristics and similar operational procedures.

Where information on resistance of safety systems, structures and components to the beyond design basis weather conditions is missing in plant documentation then engineering judgement is applied to estimate the plant response.

The results of analyses and evaluations highlights that the changes to the original design effected favourably the increase of Bohunice and Mochovce plant resistance against the extreme weather conditions, and the possibility to compensate adverse effects of extreme weather on plant technological equipment (for example, the seismic upgrading increases the resistance of the buildings against the extreme wind and snow load). Sufficient time reserves for taking measures in the extreme weather situations are shown.

However, some analyses, evaluations, used conditions, considered consequent failures of equipment or actions of plant personnel require further precision and complementary evidences to be sure that conclusions based on thereof in regard to safety of the plants are fully correct. The review concludes that it is needed:

- To update the safety report for Bohunice nuclear power plant and its referenced supportive documents dealing with external threats to be in line with international requirements and recent knowledge of meteorological conditions;
- To perform the detailed assessment of impact of extreme meteorological conditions (temperature and combination of wind/ icing)to the vulnerability of high voltage line at Bohunice and Mochovce sites;
- To assess all roof constructions of Bohunice nuclear power plant against the EUR code, and implement measures drawn up from the assessment conclusions.

4.2.1.2 Estimation of difference between the design basis conditions and the cliff edge type limits, i.e. limits that would seriously challenge the reliability of heat transfer

The estimation of safety margins against extreme weather conditions has been done for safe shutdown routes:

- Margin against direct wind, snow and icing loads for buildings and constructions, which contain components of safe shutdown roads,
- Margin against temperatures for technological equipment included in the safe shutdown routes, i.e. safety important equipment its functionality has to be maintained during external event or components, which loss of functionality, although acceptable, could endanger the components, which functionality has to be maintained (components of safe shutdown routes placed outdoor or specific air conditioning systems).

Detailed information on the quantitative or qualitative estimation of safety margins for extreme weather conditions and their combinations is provided in the nuclear power plant documentation and particular utility report. An overview of generalised major results is given in the following text.

An equivalent direct wind speed for tornado (category F1 of Fujita scale reaches 50 m/s) is less than wind speed determined for extreme wind loads (see table below). So, buildings of safe shutdown routes have been successfully evaluated for the wind loads equal to 1.2 multiple load of tornado F1 category.

Characteristics of meteorological variables – wind

Meteorological variable	Likelihood of adhering to the		
	Unit	100 years	10 000 years
Extreme wind speed for 10 minutes at 10 m above the measured surface	m/s	27.2	38.7
Maximum impact of the wind at 10 m above the measured surface	m/s	40.0	53.9

The safety margin of nuclear power plants against the snow load has been estimated as relation between the snow loads considered for the plant evaluation in the frame of design basis revision (1.40 kN/m²) and design value (1.17 kN/m²) based on STN EN 1991 standard. So, the evaluation (Mochovce NPP) shows the resistance of building of seismic categories 1 and 2 against the snow loads is about 1.2-times higher than design loads.

Safety margins for extreme weather temperatures

	Threat, °C (TR=10 000 y)	Design basis, °C	Margin, °C
Maximum temperature lasting 6 hours	+41.6	+43.8	2.2
Minimum temperature lasting 6 hours	-33.7	-44.2	8.5
Maximum temperature lasting 7 days	+33.5	+38.0	4.5
Minimum temperature lasting 7 days	-27.3	-30.0	2.7

Safety margins between the threats and design values for extreme temperatures are listed in table above. The evaluation has been performed for threats estimated for return period 10,000 years. The design of relevant equipment of the safe shutdown routs has been done for the consideration of stable conditions of external temperature and not for short-term temperature transients.

4.2.2 Measures, which can be envisaged to increase robustness of the plants against extreme weather conditions

4.2.2.1 Consideration of measures, which could be envisaged to increase plants robustness against extreme weather conditions and would enhance plants safety

Major design and construction measures and administrative arrangements, which can be envisaged to increase robustness of the Bohunice and Mochovce plants against extreme weather conditions (i.e. extreme wind, temperatures and humidity, snow amount, freeze and icing, and their combinations) include:

- Finalize the report of Slovak Hydro-meteorological Institute for Bohunice site to consider recent knowledge on meteorological conditions;
- Update the safety report for EBO3.4 and EMO1.2 nuclear power plant and its referenced supportive documents dealing with external threats to be in line with international requirements and recent knowledge of meteorological conditions;
- Perform the detailed assessment of impact of extreme meteorological conditions (temperature and combination of wind/ icing) to the vulnerability of high voltage lines at the Bohunice and Mochovce sites.

Specific proposals for changes in plant operating procedures and recommendations for preventive arrangements at the plants are provided in the utility reports. These include:

- An increase of the frequency for plant walk-down of diesel generator stations at time of low temperatures, snowing and icing;
- To design and implement preventive measures at ambient temperatures below design basis to maintain the functionality of equipment relevant to safety

Design and construction measures and administrative arrangements, which can be envisaged to increase robustness of the Bohunice and Mochovce plants against extreme rainfall and floods, are summarised in the Chapter 3 of this report.

5 Loss of electrical power and loss of ultimate heat sink

5.1 Loss of electrical power

Power supply of electric consumers important for nuclear safety, safe plant shutdown, core cooling, residual power removal and maintenance of integrity of barriers for in-depth protection is the principal prerequisite for safe NPP operation. In all units there are several possibilities for AC power supply.

In case of EBO3,4 these possibilities include:

1. One out of four plant generators, if the power is delivered to the 400 kV power grid or successful transition to home consumption has been performed
2. 2 independent lines from the 400 kV distribution grid– through power output lines to the station grid
3. 2 independent lines to stand-by unit transformers (from 110 kV Bosaca substation, from 220 kV Krizovany substation, if outlet to the 400 kV grid is disconnected);
4. One out of four plant generators, if successful transition to home consumption has been performed;
5. Three DGs for each unit – if none from the aforementioned sources is available. Connection of any one of three DGs per unit is sufficient to ensure fulfillment of safety functions.
6. In case all DGs fail to start or to connect to the emergency power supply switchboards, there is an additional possibility to recover the home consumption power supply from the Madunice hydro station by a separate 110 kV line.
7. In addition to these design solutions, the power supply of V-2 NPP can be ensured also by emergency connection of one of three 6 kV DGs with a power of 2.9 MVA from the neighboring V1 NPP.
8. Furthermore, within the ongoing SAM project an emergency diverse 6 kV SAM DG with a power of 1.2 MW is under instalation. It will be able to supply consumers also in case of a loss of other power sources considered in the design.

In Mochovce EMO 12 units the possibilities for power supply are as follows:

1. One out of four plant generators, if the power is delivered to the 400 kV power grid or successful transition to home consumption has been performed;
2. 2 independent lines from the 400 kV distribution – through power output lines to the station grid when TGs are shut down (400 kV line from Velky Dur switchyard);
3. 2 independent lines to standby transformers (from Velky Dur substation 110 kV);
4. Diverse source from Gabcikovo Hydropower Plant;
5. Diesel generator station 16 x 2 MWe situated in the 400 kV Levice switchyard;
6. Three DGs for each unit – if none from the aforementioned sources is available
7. Within the ongoing SAM project a diverse 6 kV SAM DG with a power 1.2 MW which will be able to supply consumers to mitigate severe accident consequences is being installed.
8. Furthermore, there is an on-going procurement in 2011 of additional mobile DGs of 0.4 kV with 300 kW power per unit for recharging of accumulator batteries in case of a long-term SBO and failure of all home consumption power sources.

For MO3,4 units the same possibilities as for EMO 1,2 will be available. In addition, MO3,4 design is improved in comparison to EMO1,2 design by the introduction of 400 kV breakers at the outlet of the unit main transformer. Furthermore, the MO3,4 twin-unit design includes also measures using the four-unit configuration and assuming a manual interconnection of the DG of the respective redundancy between the twin-units. After the Units 3,4 start-up, options and stability of power supply of safety appliances not only in Units 1,2 but in the entire EMO site will be improved.

In addition, there is DC power provided by the batteries.

All options are described in more detail in the text below.

5.1.1 Loss of off-site power

If, after the plant disconnection from 400 kV grid, TGs are not stopped and generators are not disconnected from the home consumption grid, the unit controllers regulate the unit to home consumption operation. In this regime, the generators ensure the unit home consumption supply. If regulation to home consumption fails, unit electric supply is recovered from the back-up power supply.

5.1.1.1 Design provisions taking into account this situation: normal back-up AC power sources provided capacity and preparedness to take them in operation, Dependence on the functions of other reactors on the same site. Robustness of the provisions in connection with seism and flooding

In case of failure or impossibility to transfer to the unit regime ensuring home consumption power supply by the unit, power supply of the unit home consumption (including emergency power supply category II sections) will be recovered from the back-up power supply. Back-up power supply is provided from 110 kV / 220kV substations.

5.1.1.2 Autonomy of the on-site power sources and provisions taken to prolong the service time of on-site AC power supply

Back-up power supply of both units is independent from the working supply and must be available in all unit regimes. Unit back-up supply has capacity dimensioned so as to provide for power supply of all unit consumers needed for operation in all regimes. Each NPP unit has own back-up power supply grid; these grids can be mutually interconnected, i.e. both units can use not only own back-up power supply, but also that of the neighbour unit. There are no time limitations for unit operation with power supplied from working or back-up supply.

5.1.2 Loss of off-site power and loss of the ordinary back-up AC power source

If unit back-up supply is not available and if the plant is disconnected from the 400kV grid and the unit fails to transfer to home consumption (or transfer to unit back-up supply fails), the unit home consumption can be supplied neither from working, nor from back-up power supply. In this case, the unit home consumption supply is recovered automatically in the minimal configuration needed for provision of the principal safety functions from the emergency power supply sources – three DGs per unit representing 3 x 100% redundancy. At this situation, the unit transfers automatically to regime 3.

5.1.2.1 Design provisions taking into account this situation: diverse permanently installed AC power sources and/or means to timely provide other diverse AC power sources, capacity and preparedness to take them in operation. Robustness of the provisions in connection with seismic events and flooding

Emergency power supply systems (diesel generators with their relevant sections) are designed as independent, while each of them is capable of supplying safety important consumers in any unit regime, i.e. 3x100 % redundancy is available.

The emergency power supply systems are fully autonomous, including automatic DG start-up, connection to 6kV emergency power supply section, loading and operation. Each DG has fuel inventory in its own tank with volume

110 m³. DG consumption was measured during the stress tests with load 1.6MW. Obtained data show that DG could remain working for 220 – 240 hours considering the load and using the complete diesel fuel inventory from the tank.

If necessary, design solution of emergency sources enable extension of their operation by alternating (switching off and keeping only one or two systems running).

All three emergency power supply systems, including reserve sources, must be serviceable in regimes 1, 2, 3, and 4. Minimally two emergency power supply systems, including reserve sources, must be available in regimes 5, 6 and 7.

Robustness of the emergency power supply system in connection with seismic events and flooding are described in respective parts of Chapter 2, Chapter 3, and Chapter 4.

5.1.2.2 Battery capacity, duration and possibilities to recharge batteries

In the considered operational regime, the batteries are permanently charged from the emergency power source (DG); thus, their capacity is kept on nominal value.

5.1.3 Loss of off-site power and loss of the ordinary back-up AC power sources, and loss of permanently installed diverse back-up AC power sources

Complete loss of home consumption power supply (black-out) may occur at loss of power supply from the grid and a failure to regulate the unit to home consumption, with loss of back-up power supply and failure of start of all the DGs or their connection to 6 kV emergency power supply sections.

EBO3,4 has an alternative power supply source for the situation with failed emergency power supplies, so called 3rd grid connection (external autonomous source). This source supplies two safety systems (one per unit, total power 5MW). The 3rd power grid connection consists of three parts: Madunice hydro plant, connecting line and substations in NPP. This source is capable to recover power supply of one emergency power supply section in each unit within 30 minutes. Emergency power supply sections can be also supplied by diesel generators from V1 NPP via the 3rd grid connection substations.

The Mochovce power plant has an alternative power supply for case of failed emergency power supply sources – a so called third grid connection (off-site autonomous source) either from Gabčíkovo hydro plant or from DGs (16 x 2 MW) in Levice switchyard.

In case of station black-out, only the sub-set of the top priority consumers remains operating ensuring limited set of functions aimed primarily at monitoring of the unit conditions and safe equipment shutdown. These consumers are supplied from three vital power supply sources. Accumulators are power supply sources of these consumers.

A serious consequence of the SBO event could be a potential loss of integrity of the RCP seals due to failure of their cooling. In case of SBO, cooling of RCP seals will not be ensured due to loss of RCP seal water flow and loss of water flow through the coolers of the RCP, which, from the long-term point, may evoke the RCS coolant leakage through the drain line from the RCP seal. According to current data, RCP seal will not fail within 24 hours after loss of cooling; longer lasting cooling failures were not analysed.

5.1.3.1 Battery capacity, duration and possibilities to recharge batteries in this situation

Accumulators for EBO 3,4 and EMO1,2 are designed for 2 hours operation for 220 V level and in addition in EMO1,2 there are also 24 V batteries designed to operate for 4 hours for without emergency power supply sources.

Design assumptions used for determination of this time were too conservative. Based on data collected during normal operation and analyses of the capacity of the batteries during real transients it was concluded they will remain operable for 8-10 hours at least. As part of the stress tests, capacity of batteries in EBO3,4 was measured with the conclusion that it is sufficient for up to 11 hours of operation.

During blackout, batteries load can be decreased by means of the power saving programme in accordance with the procedure ECA-0.0, and thus the estimated value of serviceability of accumulators during blackout may be considered as a conservative estimation. Sequential use of other accumulator systems connected with the working system by a cable is another option. There is the residual battery capacity monitoring system installed in EMO1,2 and similar system is going to be installed in EBO3,4.

5.1.3.2 Actions foreseen to arrange exceptional AC power supply from transportable or dedicated off-site source

After SBO unit home consumption is recovered from emergency sources or from working or back-up power supply. Power supply from the alternative grid (the 3rd grid connection (EBO) or Gabčíkovo switchyard or DGs in Levice switchyard (EMO)) will be used for unit stabilization only in case of failed recovery of the main sources. Connection of these power sources is described in relevant plant procedures.

In case of long-term SBO, if the unit power supply recovery failed from all of the abovementioned sources, the most important consumers will be able to be supplied from a mobile 0.4 kV DG (emergency power supply consumers of vital power supply and selected important consumers for provision of the main safety functions) at each unit. The procurement process for these mobile DGs is on-going.

5.1.3.3 Competence of shift staff to make necessary electrical connections and time needed for those actions. Time needed by experts to make the necessary connections

The shift staff is competent and trained to perform relevant manipulations to recover power supply from assumed power supply sources. In case of need, other on-duty staff or day specialists as required by TSC can be involved. NPP staff training programs contain scenarios with unit power recovery in regular intervals. During non-standard tests in EBO3,4 in 2011, power recovery of the emergency power supply sections from the 3rd grid connection was tested and it took place within 30 minutes from issuing the demand.

Recovery of working, back-up supply and emergency sources takes 1.5 hours. Recovery of power supply from the alternative grids – the 3rd grid connection in EBO3,4 and Gabčíkovo switchyard or DG in Levice switchyard in EMO1,2 requires 1.5 hours and 2 hours respectively.

5.1.3.4 Time available to provide AC power and to restore core and spent fuel pool cooling before fuel damage: consideration of various examples of time delay from reactor shutdown and loss of normal reactor core cooling condition (e.g. start of water loss from the primary circuit)

The chapter does not consider water supply from external sources and time intervals given are margins enabled by internal feedwater and coolant stock in the plant only. In case of off-site support sources the time margin would be unlimited.

Regimes 1,2,3

Core reactivity control:

After station black-out the reactors are shutdown automatically and minimum subcriticality 2% is ensured conditions - one control rod stuck in upper position and RCS cooldown to 240 °C. Recriticality can occur only after RCS cooldown to 150°C.

For the multiple failures (e.g. SBO and leaks from SC) during which positive reactivity could be inserted in case of SBO no pumps are available for injecting the boric acid concentration into the RCS. If the core sub-criticality decrease occurred, coolant containing boric acid could be supplied only from HA (HA discharge pressure for EBO, EMO3,4 is 3.5 MPa, for EMO1,2 it is 6MPa). To be prepared for HA injection to ensure core subcriticality, the RCS temperature should be decreased to allow RCS depressurisation and consequent HA injection in EBO3,4 and EMO3,4. Because of higher HA injection pressure, this is not needed for EMO1,2. At EMO1,2 during 7 hours RCS pressure is passively stabilized at 6 MPa pressure with sufficiently sub-cooled core for long term status, without needs of additional inventory and cooldown intervention requirements. In case of SBO on one unit only, boron injection pumps can be used and supplied from the other unit. These pumps can add boron to the RCS and also maintain coolant inventory in the RCS that is decreasing due to coolant shrinkage and possible small leakages from the RCS. Power supply of boron pumps will be also possible from DGs 0.4kV that are currently in the procurement process.

Time margin: If the unit is not cooled below ~240°C during SBO, no fuel damage occurs due to loss of sub-criticality for unlimited period of time. Nevertheless to protect RCP seals it will be necessary to cooldown RCS bellow 240°C after 24hours. In that case it would be necessary to increase the core sub-criticality by injecting boron solution.

Heat removal from the primary circuit

The main SBO severe consequence is endangering of heat removal from the RCS, which will occur due to loss of SG feedwater that cannot be supplied without power supply. Due to interruption of SG feedwater supply, the residual heat removal from the core leads to gradual reduction of the secondary coolant. The unit staff has at least 5 hours available till the loss of heat removal from the RCS to SC, if using only water in steam generators (about 300m³). During this time it is necessary to activate the fire department to prepare and connect a mobile emergency high pressure feedwater system (currently available only in EMO1,2, in EBO3,4 is being procured). To stabilize levels in two SGs after 5 hours from the event, 20 m³/hour of FW is sufficient. When considering the mobile source capacity ~33 m³/hour, level in selected SGs could be also increased. Heat removal from the secondary side is thus ensured for 10 days. Blackout is a common cause event affecting both units, one mobile emergency feedwater system source is sufficient only for one unit. After 24 hours from the event one mobile emergency feedwater system source is sufficient to remove heat decay from both units.

Time margin: with available emergency mobile source, more than 10 days without the off-site assistance

If the mobile emergency feedwater source is not available, level in SG will drop. Once SG heat-exchange surface becomes ineffective for the core residual heat removal, temperature in the core outlet will start to increase together with RCS pressure. When the pressurizer relief valve or the pressurizer safety valve opening pressure is reached, loss of the RCS coolant continues with deterioration of core cooling. The reactor residual power is in this phase removed by the RCS coolant evaporation to the containment. The long-term loss of heat removal from the primary circuit will gradually change to loss of the core cooling. If power supply of the unit is not recovered on time and water supply to the SG or RCS is not recovered, the initiating event of blackout type leads to fuel damage.

To prevent this scenario, it is possible to use passive gravity SG feeding from FWT; however, stresses induced in the SG collectors should be considered. SG gravity feeding ensures RCS heat removal for about 20 hours. When feedwater tanks are emptied, it is possible to continue supplying SG low-pressure feedwater to the emergency feedwater discharge by mobile fire brigade pumps installed on a fire-fighting truck platform with pressure head of 1 MPa.

If establishment of feedwater flow by fire pumps was not successful, coolant contained in HA may be used to ensure core cooling. The RCS temperature will be controlled by releasing steam from RCS through PRZ PORV/SV. In the optimum case, the coolant volume in the HAs (160 m³) can ensure the core cooling for 10 hours. It is however conservatively assumed that HA connected to the reactor upper plenum will not be fully used for the core cooling, since their volume will leak through the pressurizer relief valve/safety valve without participating in the core cooling. Thus it is assumed, that the HAs will ensure the core cooling for 5 hours only. Conditions for optimum utilization of coolant from the HAs must be formed even during the SG evaporation (RCS cooling to temperature corresponding to pressure in the HA). After emptying of HAs, the coolant volume in the RPV will ensure the core cooling for another approx. 2 hours.

Core fuel damage may occur after more than 32 hours after initiating event (see the Figure 17).

Time margin: 32 hours without off-site assistance

Based on performed stress test analysis, long-term reliable heat removal during blackout requires a modification of current provisions in order to enable high-pressure feedwater supply to the SG through the EFWS header also for the other unit in parallel (ensure another mobile EFW pump).

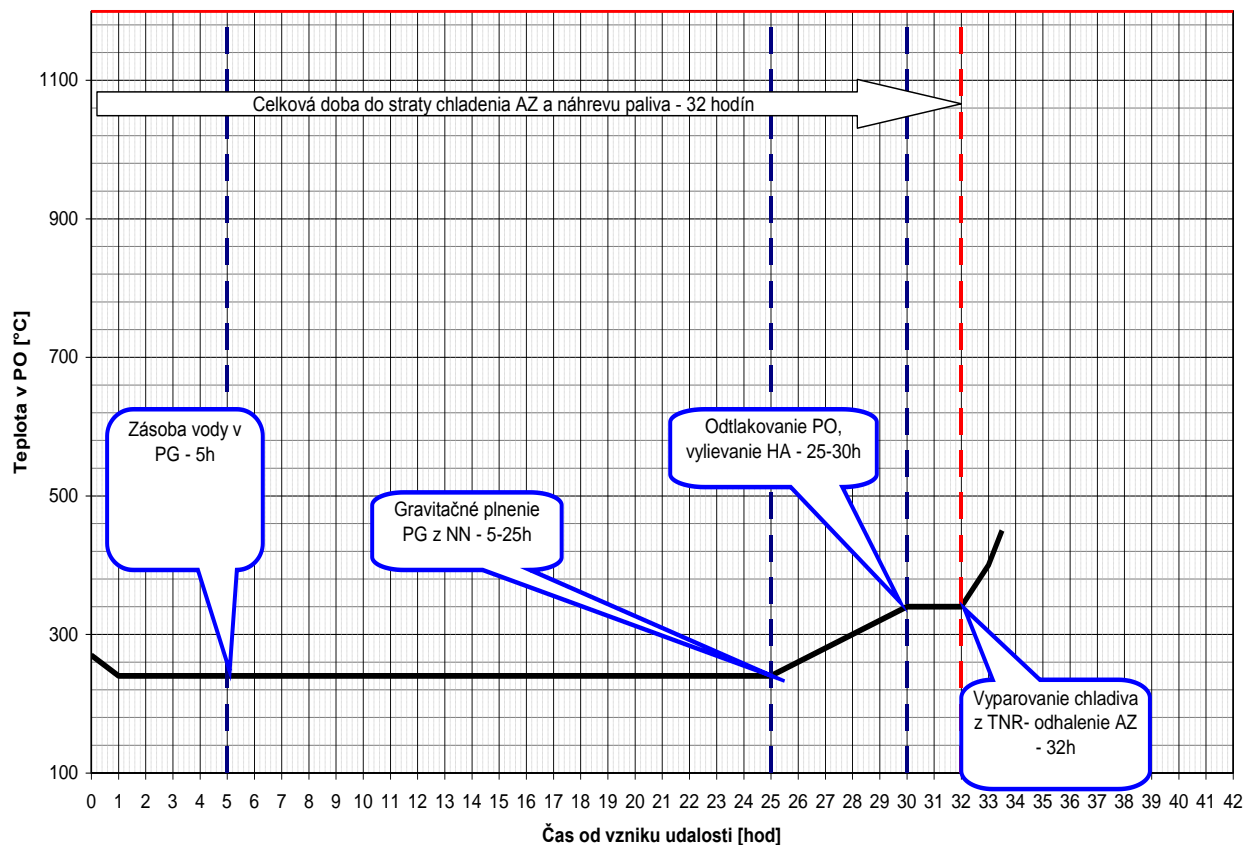

Figure 17: Temperature behaviour in core outlet during SBO

Legend:

x-axis – time elapsed from event occurrence (hours)

y-axis – temperature in RCS (°C)

zásoba vody v SG – water inventory in SG

gravitačné plnenie PG z NN – gravity feeding of SG from FWT

odtlakovanie PO ... – RCS depressurization, HA spilling

vyparovanie chladiva ... – coolant evaporation from RPV – core exposure

Time margin to fuel damage depends on the scenario:

- With SG FW supply from the fire-fighting pumps – without limitation subject to RCS tightness
- Without SG FW supply from the fire-fighting pumps using gravity SG feeding – 32 hours

Containment integrity

During SBO, heat removal from the containment is not ensured due to loss of ESCW and containment cooling systems. No alternative system is available for containment cooling during SBO; thus, temperature in the containment starts to increase. Air in the containment will cause heating of concrete containment structure after certain time delay. After 8 hours from the loss of power supply, air in the containment will reach 100°C. After two days, expected centerline temperature in containment wall is approx. 60°C. The containment integrity is not endangered at this temperature. According to the European standard Eurocode 2-1-1, concrete strength decreases by max. 6% at 127 °C. By the time of fuel damaging (32 hours from the initiating event), temperature in the containment does not exceed 110°C and pressure 140 kPa. The containment integrity is not affected at these values.

If the core cooling is lost during SBO (SG FW make-up sources are exhausted), PRZ RV opens to the containment that is supplied not only by RCS thermal losses, but also the complete residual core power, the containment heating trend will rise about 3 times and its pressure will continue to increase as well. Containment integrity could be challenged after fuel damage and subsequent hydrogen combustion. These processes are described in Chapter 6.

Time margin:

With available FW and emergency mobile pump – without time limitation

Without available FW emergency mobile source and without implementation of measures for preservation of containment integrity – 33 hours

RCS coolant inventory

During blackout, the RCS make-up is not available. Level in the pressurizer also decreases due to RCS coolant shrinkage and possible small leakages from the RCS. The cooling to 238°C itself decreases RCS coolant volume by 17m³. If assumed leak from the RCS within 24 hours is 0.5 m³/h, total decrease of RCS volume after 24 hours will be 30m³. The rest of coolant inventory in the primary circuit is sufficient from view point of the core cooling and heat removal from the core. In the time horizon for 24 hours after SBO, leaks from the RCS can be affected by possible leaks through RCP seals. If no leak occurs through RCP seals, coolant inventory in the RCS is sufficient to ensure heat removal for another 20 hours.

In the case of blackout, coolant can be added to the RCS only from HA (after RCS depressurization) or by boron pumps after implementation of the proposed modifications (connection to twin unit or use of dedicated 0.4kV DG).

Time margin: RCS coolant inventory is sufficient for fuel cooling for at least 24 hours. Further course depends on leak through RCP seals; however, no data is currently available for this case. If provisions for compensation of leaks are available, time is unlimited.

Monitoring of unit condition

Monitoring is possible only if vital power supply is available. According to values measured during the stress tests and considered capacity of VPS - batteries are sufficient for approx. 11 hours of operation. Similar estimate is 8-10 hours for EMO. When minimum capacity is reached, batteries must be switched off, because they would become irreversibly damaged after complete discharge, which would complicate plant stabilization after power supply recovery.

EBO does not have any batteries capacity monitoring system enabling correct interventions to reduce consumption, and to specify condition, when the vital power supply must be switched off. Such monitoring system is going to be installed within SAM project.

Time margin:

- If recharging of batteries from 0.4 kV DGs is available – standard unit monitoring would be available without time limitation.
- Without recharging the batteries or adopting measures for reducing the consumption – no standard unit monitoring would be available after 11 hours of blackout condition. Procedures for non standard monitoring of unit condition are under development (SAM project).

Regimes 4,5

Core reactivity control

In regimes 4 and 5, shutdown boric acid concentration is established in the RCS. Therefore, evaluation results of the core reactivity control at SBO in regime 3 can be considered as boundary assumption valid also for SBO in regimes 4 and 5.

Heat removal from the primary circuit

In regimes 4, 5 before the initiating event, heat removal from the primary circuit was in steam-water or water-water mode, or in phase of its transfer to the water-water regime. In case of SBO in regimes 4, 5 heat removal from the RCS cannot continue in the water-water mode, as it is not executable without power supply. Therefore, it is necessary to transfer the secondary heat removal to the steam-water. This requires drainage of the heat removal system and RCS heating to the temperature causing steam production in SG sufficient for all residual heat removal from the core.

The coolant inventory in SG in regimes 4, 5 is higher than the one in regimes 1, 2, 3. Residual core power in regimes 4,5 is lower due longer time elapsed from reactor shutdown, which extends time for SG depletion. Thus, the total time during which heat removal from RCS is ensured is greater than in regime 3.

Containment integrity

In regimes 4, 5, the coolant temperature in the RCS and the RCS structures is lower than in regime 1,2, 3, and also the core residual power will be lower due to longer time elapsed since the reactor shutdown. Thus, the results of assessment of the heat removal from the RCS at SBO in regime 3 can be considered a boundary estimation applicable also to the SBO in regimes 4, 5.

Monitoring of unit condition

In regimes 4,5, no higher consumptions from accumulators system 1 - 4 are assumed, and therefore, conclusions of assessment of sustainability of the unit condition monitoring at SBO in regime 1,2,3 can be considered a boundary estimation applicable to SBO in regimes 4, 5.

Regime 6

Core reactivity control:

In regime 6, shutdown boric acid concentration is already established. For reactivity control the boric acid could be supplied to RCS by gravity from the bubbler condenser tower in the case of boron concentration decrease. Therefore, results of assessment of the reactivity control in the core and in the spent fuel pool at SBO in regimes 1, 2, 3 can be considered a conservative estimation applicable also to SBO in regime 6.

Heat removal from the primary circuit

In regime 6, the RCS is depressurized and it can be also open (the RCS pressure boundary is disabled). Heat removal from the RCS before the event was in the water-water regime. After the SBO, heat removal from the RCS cannot continue in the water-water regime, which is not executable without power supply. If only RCS airvents valves are open in regime 6, which can be closed, the assessment for regimes 4, 5 is applicable to assessment of heat removal from the RCS in case of SBO. If the reactor is open, the following options are available:

- Heat removal from the core in the core boiling regime, without any operator intervention, initial coolant level 200 mm below the RPV main flange - Time margin to fuel damage about 9 hours
- Heat removal from the core in the core boiling regime. With operator intervention, but without off-site support. Coolant is added to the RCS by gravity feeding from bubbler condenser trays. – Time margin to fuel damage about 4 days;
- Heat removal from the core partially by coolant boiling in RPV and partially by steam from SG. Coolant is added to the RPV by gravity feeding from water trays and to SG either from FWT or by fire pumps, without off-site sources with MCR operator's intervention - Time margin to fuel damage about 12 days.

Containment integrity

The containment pressure boundary is disabled in the regime 6 and containment integrity cannot be endangered.

Monitoring of unit condition

In regime 6, power consumption from batteries is lower than in regime 1, 2, 3, so that these regimes envelope SBO also in regime 6.

Spent fuel pool

After station blackout, systems for residual heat removal from SFP to ESCW are inoperable. Residual heat from spent fuel pool can be removed by alternative methods only. These methods consist in decay heat accumulation in SFP coolant and in other RCS volumes or in regime of SFP boiling. When steam from SFP is evaporated to the reactor hall, coolant is added to the SFP either using passive means (bubbler containment trays) or using fire pumps.

Spent fuel pool reactivity control

Sub-criticality in the SFP is provided in two independent ways:

- Geometry and material of the storage grid
- Boric acid concentration

SFP design does not enable formation of critical conditions in the SFP even after boron concentration decrease to zero provided that no boiling takes place in the SFP. During SBO for SFP reactivity control, only passive methods are available – boric acid solution make-up to SFP by gravity from the bubbler condenser trays. During the stress tests, the flow rate was measured from trays and the flow rates were sufficient for reactivity control in the SFP.

For EMO1,2 lower grid of SFP it was justified, that even if assuming local decrease of subcriticality due to boiling, the grid with hexagonal absorption tubes itself is sufficient to prevent occurrence of critical assembly. Thus, there is no risk of reactivity control endangering at pure condensate make-up. Similar analysis should be performed also for EBO 3,4.

Heat removal from the spent fuel pool

In case of SBO, standard heat removal from the spent fuel pool through the ESCW is not available. Spent fuel residual power accumulates in the coolant and SFP structures and temperature in SFP starts to rise. Depending on residual power of fuel in the spent fuel pool, which can range from 1.25 MW to 5 MW, and coolant inventory in the spent fuel pool before the event, there are time margins available according to the table below (data for EBO 3,4, without operator's intervention).

After blackout the only way for SFP cooling is passive make-up of the SFP from 7 bubbler condenser trays above SFP level, which ensures SFP cooling by heating-up coolant from the trays from 40 °C to 60 °C for 4 to 14 hours, depending on spent fuel residual power. After reaching the boiling point, cooling is provided by evaporation of coolant from SFP. To maintain required coolant inventory in the SFP, it is necessary to ensure its make-up from other sources (fire pumps). SFP make-up need per unit for residual heat removal from SFP by coolant boiling ranges from 2 m3/hr (for power 1.25 MW) to 8 m3/hr (power 5 MW). Steam produced in SFP is being removed to the atmosphere.

Time margins to damage of fuel in SFP depend on amount/residual heat of spent fuel and on initial coolant inventory. Some quantitative data without operator interventions (without alternative cooling) are seen from the next table. These margins can be extended by 4 – 14 hours by using water from the trays.

All fuel is off-loaded to SFP, level in SFP 21.27m

Fuel power	Level	Boiling in SFP	Coolant evaporation above the fuel	Complete coolant evaporation under the fuel and temperature 1,200°C
4,87MW	21,27m	2h 48min	+20h 45min	+6h 52min

Only spent fuel from previous campaigns is placed in SFP, level in SFP 14.46m

Fuel power	Level	Boiling in SFP	Coolant evaporation above the fuel	Complete coolant evaporation under the fuel and temperature 1,200°C
1,25MW	14,46m	5h 14min	+37h 33min	+19h 15min

Only spent fuel from previous campaigns is placed in SFP, level in SFP 21.27m

Fuel power	Level	Boiling in SFP	Coolant evaporation above the fuel	Complete coolant evaporation under the fuel and temperature 1,200°C
1,25MW	21,27m	10h 55min	+127h 55min	+19h 15min

Similar estimate of the time margins was made for EMO1,2 and EBO3,4 considering two kinds of SFP cooling:

- Make-up of SFP passively by gravity make-up from 7 containment trays installed above the SFP level +21m and increase of level from +14.45m to +21,17m (also considering the need to remove heat from the reactor core);
- SFP drainage through the overflow on +21.22 m to LP ECCS tanks (if empty) or RCS drainage tank and SFP filling from containment trays

By realizing of these measures time to boiling will be increased by 5 to 10 hrs.

Further heat removal from SFP after exhaustion of the alternative cooling (5 – 10 hours after SBO) and SFP heating to the boiling point after another 2.6 hours for unloaded fuel from the reactor core (level on +21,17m) up to 10.7 hours for fuel assemblies in the basic rack only (level at +14.46m) can be ensured by coolant evaporation. To maintain required coolant inventory in SFP, it is necessary to ensure its make-up from other sources (bubbler condenser trays by gravity, fire pumps). SFP make-up need per unit at heat removal from SFP by coolant boiling ranges from 2 m3/hr (power 1.25 MW) to 8 m3/hr (power 5 MW). Steam generated in SFP is removed to the reactor hall.

Times without staff intervention are given in the following table:

Event SBO	Fuel assemblies in both grids +21.17 m/ 4.8 MW Time [h]	Fuel assemblies in basic grid only +14.46 m/1.26 MW Time [h]
Start of Event	0	0
Reaching of saturation limit –	2,6	10,7

Event SBO	Fuel assemblies in both grids +21.17 m/ 4.8 MW Time [h]	Fuel assemblies in basic grid only +14.46 m/1.26 MW Time [h]
boiling in SFP		
Exposure of stored fuel assemblies	23	42,5
Damaging of fuel assemblies 1,200°C	30,5	62

If filling of SFP by fire truck is applied the time margin is unlimited.

5.1.4 Conclusion on the adequacy of protection against loss of electrical power

The vulnerability against SBO is adequate, the design allows for approximately 30 hours margin (as a minimum) in provision of core cooling and spent fuel pool cooling safety functions.

5.1.5 Measures which can be envisaged to increase robustness of the plants in case of loss of electrical power

Evaluation of safety margins of V213 design at SBO proved the ability to ensure protection of safety barriers during considerably long time, thus providing sufficient time for accident management actions for recovery of the plant power supply. Despite the robustness of the current plant design, it can be improved by the following modifications and supported by tests and analyses:

- To increase resistance and reliability of EPS for beyond design basis events (installation of new 6kV emergency SAM DG)
- To provide for 0.4 kV DG for each unit for charging batteries and supplying selected unit consumers during SBO
- modifications of the power supply (also from 0.4 kV DGs) of the HP boron system pumps enabling their use during SBO
- To provide for technical solution and cable pre-preparation in order to facilitate mechanical interconnection of accumulators between systems.
- To provide the mobile high-pressure source of SG feedwater available during SBO, with minimal flow rate 20-25 m³/hr for one unit and with pressure head 6 MPa, and ensure logistics of supplies for the mobile source, with possible use for both EBO3,4 and EMO3,4 (the same nozzle types)
- To optimize emergency illumination in order to extend life time of batteries (subdivision into sections with the possibility for switching off unnecessary parts, use of energy saving bulbs)
- To obtain data documenting behaviour of RCP seals at long-term failure of cooling (more than 24 hours)
- To provide for monitoring system of capacity of batteries (for EBO3,4)
- To provide for mobile measuring instruments able to utilize standard measuring sensors (e.g. thermocouples)
- To provide for power supply of containment drainage valves and HAs isolation valves from the vital power supply system (EMO)
- To consider possibility to control selected valves without vital power supply by means of small portable motor 3-phase generator 0.4 kV (max. 7 kW)

- To install two physically separated fixed pipelines for make-up of the coolant inventory in SFP from a mobile source (fire pumps) and external water source dedicated for SA.
- To assure long-term serviceability of communication means for MCR operators and shift service staff
- To develop operating procedure for possible use of diesel generators installed in Levice switchyard for SBO event (for EMO).

5.2 Loss of the decay heat removal capability/ultimate heat sink

The primary UHS is the surrounding atmosphere. Heat removal from the core, SFP and containment to ESCW and CW to the primary UHS in individual operating regimes is provided by various systems: In case of ESCW failure, the chain of systems participating in heat removal from the core, containment and SFP to the ultimate heat sink is interrupted at least in one regime. Thus, ESCW system is inevitable for provision of simultaneous long-term heat removal from the core, containment and SFP to UHS (atmosphere) at least in one unit regime. Complete, immediate and long-term loss of operability of all three ESCW system circuits can be considered as an envelope case of UHS loss that is conservatively covered by the previous SBO event analysis described in chapter 5.1. Considering low probability of immediate simultaneous mechanical failure of all ESCW systems, in following evaluation the scenario resulting in loss of UHS due to interruption of raw make-up water supply will be considered.

5.2.1 Design provisions to prevent the loss of the primary ultimate heat sink, such as alternative inlets for sea water or systems to protect main water inlet from blocking.

The ESCW system is the supporting system for core cooling safety systems. According to the UJD SR Decree No. 50/2006 Coll., it has been classified in the safety class 3. ESCW fulfills the safety function of heat removal from safety systems to the primary UHS (atmosphere). ESCW should provide not only for the ultimate heat removal system, but also to cool all consumers requiring uninterrupted cooling water supply.

ESCW system is designed as redundant 3x 100%; each system contains 2 pumps per unit (2x100%) and 2 forced draft cooling towers sections (2x100%). ESCW system is resistant against a single failure and a common-cause failure (fire, flooding, seismic events, interactions from high-energy pipes, flying objects, fall of a load, environmental conditions and extreme climatic conditions). ESCW circuit parts are mutually physically separated. Every ESCW system is supplied from different section of the emergency power supply in compliance with supplying of independent circuits of the core emergency cooling. ESCW system is common for both NPP units in the part of ESCW pools, main supply and return pipelines. Therefore, the neighboring unit can fully cover ESCW cooling requirements also in case of own unit system failure.

Twin-unit design of ESCW systems on the level of ESCW pumps and FDCT improves the system reliability, as the probability of unavailability of the complete system is lower than in case of single-unit design due to the power supply design solution of ESCW pumps and FDCT fans from both units and sufficient capacity 2/4 for one ESCW circuit, thus increasing the resistance against certain failure mechanisms of common cause.

ESCW system is dependent on equipment out of the NPP area supporting its operability. Considering ESCW operability, the most important among these systems is the raw make-up water supply system.

For EBO 3,4, raw make-up water can be supplied from water reservoir Slnava and the river Dudvah. Suctions from the water reservoir Slnava – Drahovce dam and Madunice hydro plant are supplied by the river Vah. The pumping station Pecenady is supplied with make-up water by gravity via four pipelines. From pumping station

Pecenady to EBO3,4 raw make-up water is pumped through two pipelines. Raw make-up water for EBO3,4 can be supplied by independent piping system via V1 NPP.

In EMO3,4, the raw make-up water supply system is designed as operational system with double redundancy from the in-take point Male Kozmalovce on the river Hron.

Equipment ensuring water supply is protected against inlet clogging and freezing of sensitive system parts. However, in general the make-up water system is an operational system that was not upgraded for beyond-design basis external events including seismic events. Considering this fact, the protection against loss of UHS consists mainly in sufficient water inventory in ESCW and CW pools.

EBO 3,4 has total water inventory of 42,890 m³ in the cooling water pools and 1,613 m³ of usable water in each ESCW pool. In some regimes, another 37,510 m³ of raw water is available in the inlet of raw water pipelines that can be supplied to NPP from operating pumping station Pecenady. In Mochovce, the total water inventory in NPP area is 44,000m³ in CW and 4,830m³ in all ESCW systems.

5.2.2 Loss of the primary ultimate heat sink (e.g. loss of access to cooling water from the river, lake or sea, or loss of the main cooling tower)

Loss of the main UHS can be initiated (with essential time delay) only in the case of loss of all ESCW systems in both units. Complete failure of all ESCW systems in both units can occur due to SBO, common cause failures (e.g. I&C failure) or it can result from the BDBA e.g. beyond design basis flooding or earthquake.

Complete loss of operability of all three ESCW trains can be considered as an envelope case of UHS loss that is conservatively covered by the previous SBO event analysis described in Chapter 5.1. For evaluation of other scenarios leading to loss of ultimate heat sink, the event with interruption of raw make-up water supply to NPP site was considered.

5.2.2.1 Long-term raw water supply to NPP area

The coolant inventory in the ESCW system decreases due to leakages, evaporation and water carry-over (0.5% flow rate on FDCT). The required coolant repository in ESCW is maintained by raw filtered water make-up from pumping stations. Available provisions are discussed below separately for each plant.

EBO 3,4

Besides the main source of raw water, ESCW basins can be fed from SCW system and from V1 power plant. All these lines are not seismically qualified, and thus their failure after the design-basis seismic event is assumed. In such case, ESCW systems can be supplied by mobile means from off-site sources.

After loss of make-up raw water the reactor is shutdown in one hour. Total usable ESCW water inventory is 1,613 m³. It was proven that the water inventory in the ESCW systems is sufficient for coverage of ESCW losses for 72 hours. After this time it is necessary to ensure make-up of ESCW pools. Required ESCW make-up flow decreases from value of 87 m³/hr (3 days after the reactor shutdown) to 30 m³/hr (one month from the reactor shutdown).

ESCW basins can be fed from water inventory in CW pools containing 42,890 m³ of water (considering minimal operating level in CW pools). This volume will be sufficient for ESCW make-up for approx. one month of operation from the initiating event. If loss of raw make-up water supply event occurs during power operation, approx. 10,000 m³ of this water is consumed for reactor shutdown and cooldown to regime 3. In such case only

32,890 m³ of water would remain in CW pools for make-up of ESCW basins, which would be sufficient for approx. 21 days.

EMO 1,2

Required coolant inventory in ESCW is maintained by raw make-up water supply from the pumping station in Male Kozmalovce. Raw water is accumulated in the water reservoir 2 x 6,150m³ on the site. In addition to this supply, ESCW system can be replenished from the CW system. ESCW pumps are seismically resistant.

After failure of the raw make-up water, level in the ESCW system will drop. ESCW circuit has total water inventory of 4,853m³. Reduction of amount of coolant depends on the operational regime and recovery actions started.

With regard to decrease of ECSW inventory the most unfavorable situation is the event during operation at power. Fast recovery of raw make-up water supply is not assumed; thus, both reactors should be shut down to regime 2 (within 6 hours), followed by establishment of shutdown boron concentration for 8 hours; then, residual heat is removed by:

- SDSC to MC to CW and to atmosphere;
- SDSA directly to the atmosphere, with sufficient demineralized water inventory for 10 days.

By this sequence the temperature 130°C is reached. The further cooldown of the RCS can be done through primary RHR system depending on the availability of the ESCW.

After failure of the raw make-up water to ESCW 4,853 m³ are available in all three trains. Water inventory in ESCW systems is sufficient for covering losses from ESCW for 3 days from interruption of raw make-up water supply. After this time it is necessary to ensure make-up of ESCW trains from alternative sources.

Another procedure was developed enabling alternative make-up of ESCW system using a mobile pump independent on electrical power supply, with its suction connectable to the circulating water system that enables use of 44,000 m³ from 4 CW pools. 13,620 m³ water remains in CW to be used for ESCW, which is sufficient for another 9.4 days.

Water inventory from CW pools potentially may not be available after seismic event; therefore, use of off-site water inventory by truck cisterns is another possibility.

Forced draft cooling towers of the ESCW system provide for direct heat removal from ESCW system to the ultimate heat sink (atmosphere). In case of failure of several cooling towers, heat starts accumulating in ESCW system and relevant ESCW system will have to be switched off. Considering the design of ESCW system common for both units in the part of FDCTs, the neighboring unit can fully cover demand for ESCW cooling even in case of 2 failed FDCTs out of 4 in given system. Thus, loss of the ultimate heat sink due to FDCTs failure could occur only if none of the ESCW system would have at least two FDCT cells operating. However, if minimally one FDCT remains operating on two ESCW systems, no ultimate heat sink loss would occur, as reduced capacity of two working systems would be sufficient to cover cooling requirements. In winter, heat removal is sufficient even without working fans.

Integrity of RCP seals after loss of cooling

Possible loss of integrity of RCP seals is a serious consequence of ESCW failure. In case of ESCW loss, cooling of RCP seals will not be ensured due to loss of the RCP seal water flow and loss of the ESCW flow through coolers of the RCP, which, from the long-term point, may evoke the RCS coolant leakage through the RCP seals let-down lines.

Test results performed on full scope RCP seal model by the pump manufacturer showed that conditions endangering the seal integrity do not occur within 24 hours from loss of RCP cooling.

5.2.2.2 Availability of an alternate heat sink, dependence on the functions of other reactors on the same site

In case of loss of all ESCW systems, residual heat from the core can be removed directly by steam (via SG SDSA, SG SV) to atmosphere or via other systems independent on ESCW (SDSC, steam reduction stations), while ensuring feedwater flow to SG. Feedwater flow to SG is provided by EFWP from three demineralized water tanks. With this regard, the ultimate heat sink is ensured by normal heat removal system from the core using SG SDSA. This heat removal method is fully usable for regimes 1 to 5. In regime 6 with open reactor, residual power from the core can be removed for limited time by adding coolant to reactor/refuelling pool from other sources of coolant (coolant volume in RCS, emergency tanks, containment water trays) and after the reactor/refuelling pool level increase to +21m. The pressure above the core will enable steam removal from SG via SG PORV. Only minor portion of residual heat will be removed on account of coolant evaporation from reactor/refuelling pool to the reactor hall.

However, heat removal via the alternative system does not ensure residual power removal from auxiliary technological systems (cooling of intermediate circuits, vent systems, etc.), confinement and SFP and thus, it is not a full scope heat sink method to ESCW. However, it will ensure core heat sink without external FW sources for more than 10 days.

For containment and SFP heat removal for limited time various standard and non-standard interconnections included in the configuration database can be used.

5.2.2.3 Possible time constraints for availability of alternate heat sink and possibilities to increase the available time

In case of failure of all ESCW systems, residual heat from the core can be removed directly by steam release (via SG SDSA, SG SV) to the atmosphere or via other systems (technological condenser, steam reduction stations) to the circulating water and then to atmosphere, while ensuring feedwater flow to SG. The time of maintaining of this regime is limited. The power plant has coolant inventory for EFW pumps for 10 days (EMO) or 7 days (EBO) for both units. After this time, make-up of these tanks from an external source must be provided to ensure heat removal from the core.

If after the ESCW loss the coolant inventory for the SG make-up is exhausted, level in the SG will start to decrease. The time, during which the nominal coolant inventory in 6 SGs can ensure heat removal from the RCS depends on decay heat power, i.e. on time elapsed from reactor trip. Therefore it is dependent also on previous heat removal mode and used means. After SG drying they can be filled by gravity from the FWT. Gravity SG filling has limited capacity and when both feedwater tanks are exhausted, it is possible to continue supplying SG using low-pressure feedwater using mobile fire brigade pumps.

In case of open reactor (regime 6), residual heat from the core can be accumulated for limited time in the RCS coolant inventory, and also in inventory of ECCS tanks and containment trays. After all coolant accumulation capacity is exhausted, the decay heat can be removed by steam removal from SG and partial RCS coolant evaporation, whereas decreasing RCS and SG coolant inventory will be covered. In this case, establishment of required configuration takes several hours.

5.2.3 Loss of the primary ultimate heat sink and the alternate heat sink

Loss of the main UHS can occur only in case of loss of all ESCW systems in both units. Complete loss of operability of all three ESCW systems can be considered as an envelope case of UHS loss that is conservatively covered by SBO event analysis described in chapter 5.1. For evaluation of other scenarios leading to loss of ultimate heat sink, the event with interruption of raw make-up water supply of NPP site was considered.

ESCW system ensures residual heat removal from the core in some regimes and from SFP and containment in all regimes. It also provides supporting services for equipment used for reactivity control and core cooling. Therefore, trip of all ESCW systems has serious consequences on the reactivity control in the core and in the spent fuel pool, heat removal from the core and SFP, and may affect also containment integrity. Failure of all ESCW systems would lead to loss of cooling of the following systems:

DG, emergency core cooling systems, spray systems, SFP coolers, HVAC in respective rooms. Moreover, cooling of all operated systems that use ESCW will be lost: containment recirculation system coolers, containment room HVAC, cooling of the primary circuit normal make-up system, intermediate circuit coolers, auxiliary feedwater pumps, secondary RHR system.

Consequences of evaluated scenario on safety functions in individual unit regimes are described below.

Regime 3

Core reactivity control

In case of any event affecting heat removal from the core reactor is either tripped automatically or manually. Minimum subcriticality 2% is ensured even in case of one control rod stuck in upper position and RCS cooldown to 240°C. For the events during which positive reactivity could be inserted in case of all ESCW systems failure, design systems for control of boric acid concentration in the primary circuit will not be available. The core reactivity control in this case is ensured using high pressure boron pumps. These pumps can establish cold shutdown boron concentration in RCS and maintain also the coolant inventory in the primary circuit, which will be reduced due to leakages from the primary circuit. After ESCW failure if the system boron system remains operable, the reactivity control in the core and RCS coolant inventory will be ensured in sufficient extent.

Heat removal from the core

Due to different water resources on the site and different assumptions and systems used for heat removal estimates of time margins, assessment is presented separately for EBO 3,4 and EMO 12 units.

EBO 3,4

After loss raw water it is necessary to shut both units to regime 3. Heat from the core will be removed by steam from SG to the secondary RHR system operable in this stage. The unit cannot be cooled to cold conditions without ESCW, but it can be maintained in regime 3. The time for maintaining this regime is limited. Conservatively no ESCW make-up is assumed. In the evaluation also main feedwater pumps operation is not considered. After 72 hours level in ESCW basins will decrease to the minimum, and all three ESCW systems should be stopped. AFWP that are cooled by ESCW cannot be used for SG feeding and SG will have to be fed using EFWPs not requiring ESCW operation. The power plant has coolant inventory for the emergency feedwater pumps 920 m³ for both units in each of the 3 tanks. This inventory cannot be maintained after raw water supply failure to NPP. Heat from the core will be removed by steam from SG via SG SDSA / SG SV directly to the atmosphere. This inventory 72 hours after the reactor shutdown is sufficient for heat removal from the core for another 7 days for both units.

After ESCW shutdown, the reactor is further cooled to 238°C in order to enable gravity feeding and connection of HA to the RCS. After depletion of EFW tanks, SG can be further supplied by fire pumps. This heat removal mode is not time limited.

If SG make-up by fire pumps is not assumed after ESCW loss, nominal coolant inventory in six steam generators is sufficient for heat removal from the RCS for 50 hours. After SG drying it is possible to use gravity SG feeding for RCS heat removal. Gravity feeding of SG can ensure heat removal from SG for 60 hours.

After depletion of the gravity feeding, SG will be dried-out by residual heat and temperature and pressure in RCS start to rise. When the pressurizer relief valve or the pressurizer safety valve opening pressure is reached, loss of the RCS coolant continues and the core cooling deterioration continues as well. The reactor residual power in this phase is removed by the RCS coolant evaporation to the containment.

Coolant in HA can be used in this phase for delaying the fuel cladding damage. In the optimum case, the coolant volume in the HA (160 t) can ensure the core cooling for 40 hours. HAs connected to the reactor upper plenum may not be optimally used for core cooling. Thus it is conservatively assumed that the HAs will ensure the core cooling only for 20 hours. After emptying of HA (if RPV is still full), the coolant volume in the RPV will ensure the core cooling for another approx. 10 hours.

The aforementioned estimations of time margins of the heat removal from the core at loss of UHS did not consider RCS coolant leakage through RCP seals, which could occur after failure of the RCP seals cooling for the time longer than 24 hours.

Time margins estimated for the above described processes are shown in the Figure 18.

Time margin to fuel damage following loss of UHS loss depends on scenario:

- With feedwater supply to SG from fire pumps – without real time limitation
- Without feedwater supply to SG from fire pumps – 380 hours

EMO 12

In case of ESCW failure – either due to raw make-up water loss (after 72 hours) or ESCW unavailability, neither the RCS residual heat removal system, nor RCS and SC RHR are available and heat from the core cannot be removed even in the primary Feed & Bleed regime. Due to ESCW loss, primary circuit high-pressure make-up systems are not operable, and only low pressure boron pumps are available to maintain the minimum RCS coolant inventory needed for the heat removal from the primary circuit to the secondary circuit.

Heat removal from the core through the secondary circuit can be maintained by the normal heat removal system from SG through relief valves to condenser in the main header to cooling water and then to atmosphere. SG make-up will use normal feedwater pumps or emergency feedwater pumps, since the auxiliary feedwater pumps will not be serviceable due to ESCW loss. Conservatively no ESCW make-up is assumed (CW pools contain inventory for ESCW make up for at least 12-33days). For heat removal from the core to SDSC or SDSA / SG SV are used and SGs will be filled by EFWPs. (72 hours during which after initiating event the ESCW could be in operation is not considered in the evaluation). The unit cannot be cooled down and maintained in cold conditions, but it is possible to maintain it in semi-hot conditions), at which steam will be produced in the SG in the temperature range from nominal up to 100°C.

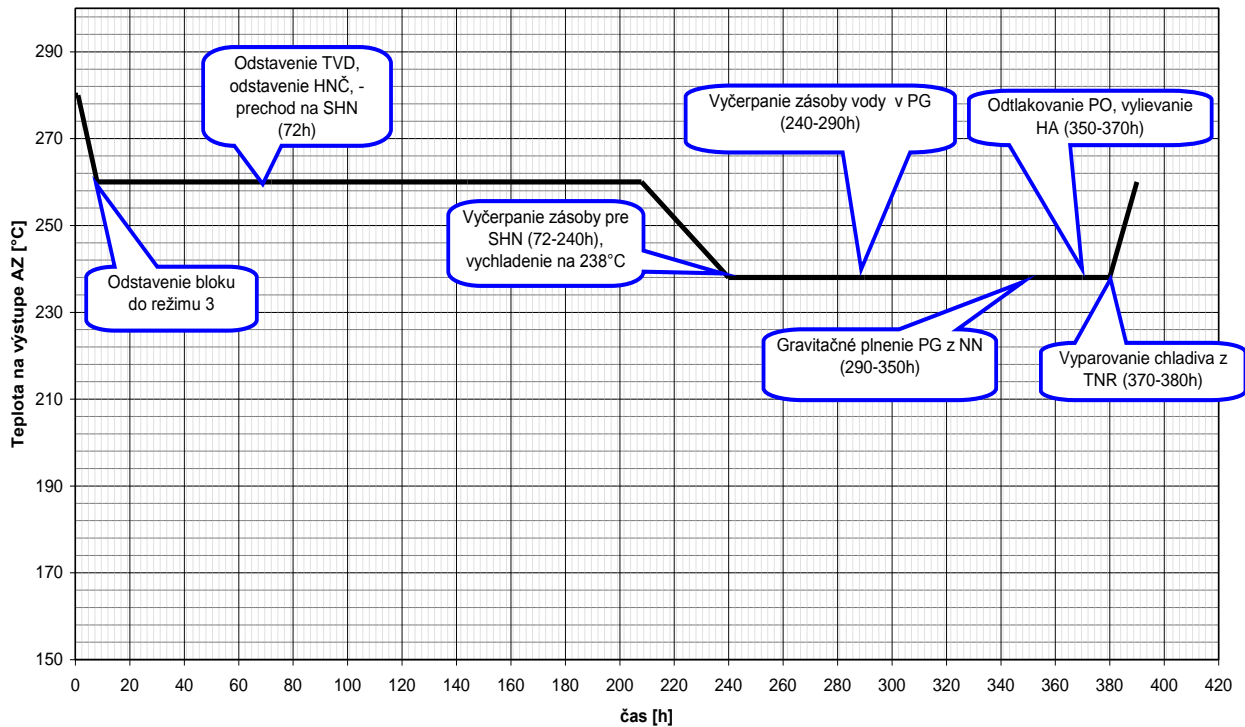

Figure 18: Temperature behaviour in core outlet during loss of UHS

Legend:

x-axis – time (hours)

y-axis – teplota ... - temperature on the core outlet (°C)

odstavenie bloku do režimu 3 – reactor shutdown to regime 3

odstavenie TVD, ... - ESCW shutdown, AFWP shutdown, transfer to EFWS

vyčerpanie zásoby ... - depletion of inventory for EFWS, cooling to 238°C

vyčerpanie zásoby vody v PG – depletion of water inventory in SG

gravitačné plnenie PG z NN - gravity feeding of SG from FWT

vyparovanie chladiva z TNR – coolant evaporation from RPV

Note: The diagram is conservative because the possibility to make-up service water system volume from circulating water pools is not taken into account. This could however extend ESCW availability for additional 10-30 days.

The power plant has coolant inventory for operation of the emergency feedwater pumps for more than 10 days for both units when assuming inventory of 2,400 m³ in three demineralized water tanks per unit. After this time, make-up of these tanks from an external source with the flow rate of about 7 m³/hr for both units must be provided to ensure core heat removal. The design does not consider simultaneous unavailability of emergency feedwater pumps in both units, and one mobile source in the first 24 hours is not sufficient for both units.

If after ESCW loss, the aforementioned methods of maintaining the semi-hot condition of the RCS fail or are exhausted, i.e. the coolant inventory for the SG make-up is exhausted (after 10 days from the reactor shutdown) and no feedwater can be provided from external sources, level in SG will start to decrease. At this time, the nominal coolant inventory in 6 SGs after the emergency feedwater system loss is sufficient for the heat removal from the RCS for 35 hours. After SG drying it is possible to use gravity SG feeding for heat removal. Gravity SG feeding has limited capacity and can even result in non-design stress of SG tubes. When both feedwater tanks are exhausted, it is possible to continue supplying SG low-pressure feedwater to the emergency feedwater pump discharge by mobile fire brigade pumps.

If SG make-up by mobile fire brigade pumps does not start after exhausting of both feedwater tanks (after approx. 40 hours from commencement of the gravity make-up), the RCS will start to heat up by the reactor residual power, and pressure in the RCS will start to increase. When the pressurizer relief valve or the pressurizer safety valve opening pressure is reached, loss of the RCS coolant continues and the core cooling deterioration continues as well. The reactor residual power is in this phase removed by the RCS coolant evaporation to the containment. The long-term loss of heat removal from the primary circuit will gradually change to loss of the core cooling. If the heat removal from the core is not recovered on time, the initiating event in this scenario leads to the fuel damage.

Time margins estimated for the above described processes are shown in the Figure 19.

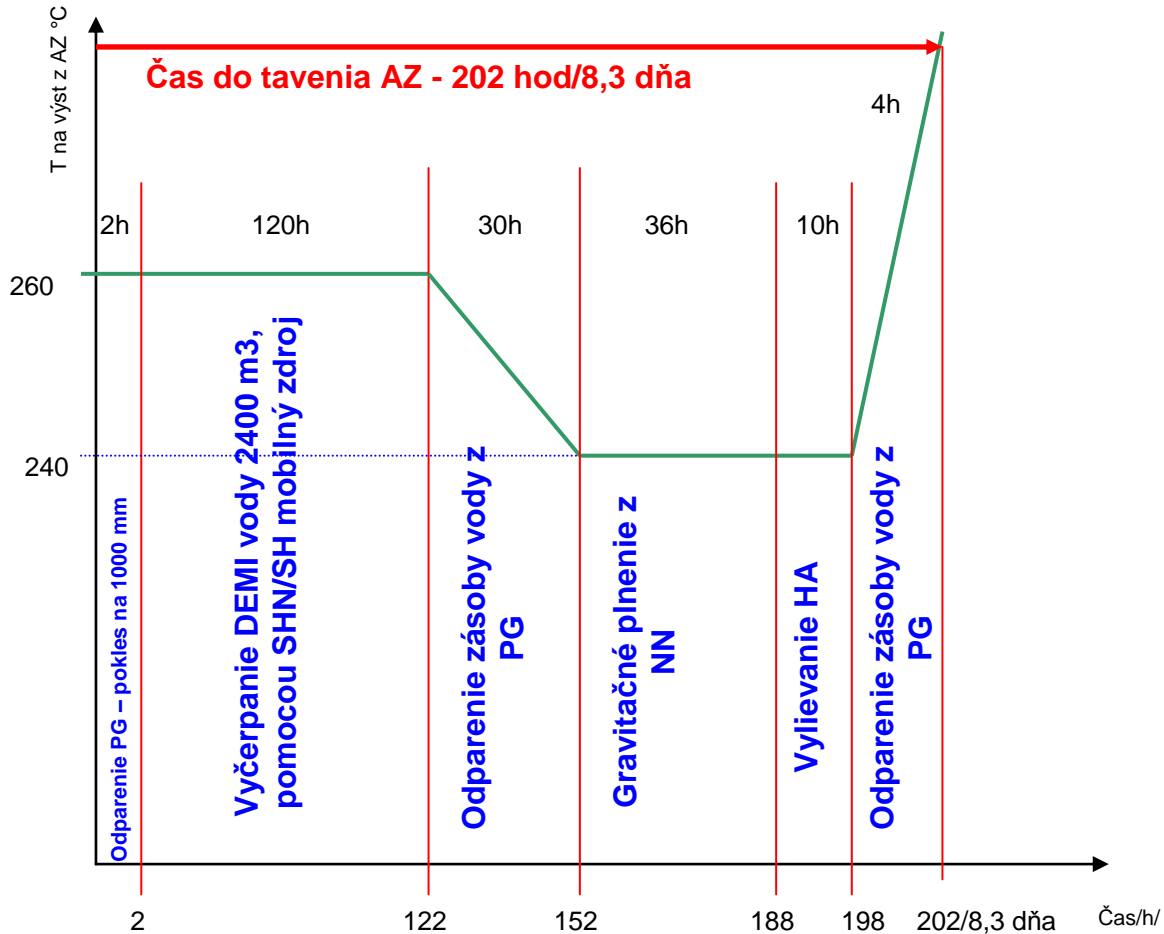

Figure 19: Temperature behaviour in core outlet during loss of UHS and normal FW

Legend:

x-axis – time (hours)

y-axis – temperature on the core outlet (°C)

odparenie PG - SG evaporation – decrease to 1,000mm

vyčerpanie DEMI vody ... - exploitation of demineralized water 2,400m³ using EFW / emergency mobile source

odparenie zásoby ... - evaporation of water inventory from SG

gravitačné plnenie z NN – gravity feeding from the FWT

vylietanie HA – HA spilling

odparenie zásoby ... - evaporation of water inventory from SG

Coolant in HA can be used for delaying the fuel cladding damaging. In the optimal case, the coolant volume in the HA can ensure the core cooling for more than 10 hours. Conditions for optimal utilization of coolant from

HA must be formed even during the SG evaporation (RCS cooling to temperature corresponding to pressure in HA). If the RPV is filled after emptying of HA, the coolant volume in the RPV will ensure the core cooling for another approx. 4 hours.

Time reserve to fuel damaging at UHS loss due to ESCW loss is 8.3 days.

After ESCW failure in relation to the scenario, heat removal from the core can be maintained in relation to availability of the heat removal systems. In optimum case after ESCW failure, heat removal from the core can be maintained for a long time by the emergency feedwater system and make-up of demineralized water tanks. For this case, the MCR operator is able to maintain heat removal only with own sources for more than 14.2 days.

Time reserve to fuel damaging at UHS loss depends on event scenario:

- With feedwater supply to SG – without real time limitation
- Without feedwater supply to SG from fire brigade pumps – 14.2 days

Containment integrity

Due to long-term loss of raw water supply to NPP after 72 hours, all ESCW pumps will have to be stopped and heat removal from the containment is not available. No alternative system is available for containment cooling; thus, temperature in the containment starts to increase. Air in the containment will cause heating of concrete containment structure after certain time delay. After two days, expected temperature in containment wall center is 60°C. The containment integrity is not endangered at this temperature. According to the European standard Eurocode 2-1-1, concrete strength decreases by max. 6% at 127°C.

If the core cooling is lost during UHS loss (SG FW make-up sources are exhausted), PRZ RV opens to the containment that is supplied not only by RCS thermal losses, but the complete residual core power, the containment heating trend will increase about 3 times and its pressure will continue to increase as well. Containment integrity could be challenged after fuel damaging and subsequent hydrogen combustion. Further information is in chapter 6.

Regimes 4,5

Core reactivity control

In regimes 4, 5, the shutdown boric acid concentration is established in the primary circuit. Thus, the results of assessment of the reactivity control in the core and in the spent fuel pool at the UHS loss in regimes 1, 2, 3 can be considered a conservative estimation applicable also to the UHS loss in regimes 4 and 5.

Heat removal from the primary circuit

In regimes 4, 5 before the initiating event, heat removal from the primary circuit was in the water-water regime, or in the phase of its conversion to the water-water regime. In case of UHS in regimes 4, 5, it is not possible to continue with heat removal from the primary circuit in the water-water regime, which is impossible without ESCW, and thus it is necessary to transfer to the steam-water regime requiring draining of the secondary RHR system and RCS heating to temperature, at which such quantity of steam is produced that will be sufficient for removal of the current residual heat of the core.

The coolant inventory in SG in regimes 4, 5 is higher than in regime 3. In regimes 4, 5, the core residual power will be lower thanks to longer time from the reactor shutdown (more than 24 hours). Thus, the results of

assessment of the heat removal from the RCS at UHS loss in regime 3 can be considered a conservative estimation applicable also to the UHS in regimes 4, 5.

Containment integrity

In regimes 4, 5, the coolant temperature in the RCS and the RCS structures is lower than in regime 3, and also the core residual power will be lower thanks to longer time elapsed from the reactor shutdown. Thus, the results of assessment of the containment integrity at UHS loss in regime 3 can be considered a conservative estimation applicable also to the UHS loss in regimes 4, 5. Therefore, containment integrity in regimes 4, 5 can be considered satisfactory from long-term point.

Regime 6

Core reactivity control

In regime 6, shutdown boric acid concentration is established in the primary circuit. Thus, the results of assessment of the reactivity control in the core and in the spent fuel pool at the UHS loss in regime 3 can be considered a conservative estimation applicable also to the UHS loss in regime 6.

Heat removal from the primary circuit

In regime 6, the primary circuit is depressurized and it can be also open (the RCS pressure boundary is disabled). Heat removal from the RCS before the event was in the water-water regime. After loss of all ESCW systems, heat removal from the RCS cannot continue in the water-water regime. The following alternatives are available for heat removal from the RCS:

- Heat removal from the core in boiling regime.
Coolant is supplied to the RCS from tanks of emergency cooling system. Coolant inventory in tanks is 660-700 m³, which is sufficient for the core cooling for 50-70 hours. In real case, coolant from containment trays that can be used for the core cooling will be also available. It is assumed that in the worst case, coolant from 9 trays should be available that can ensure the core cooling for another 90 hours.
Time margin to fuel damage: 140 hrs for EBO 3,4; similar estimate for EMO 1,2 gives 160 hrs
- Heat removal from the core partially by coolant boiling in RPV and partially by steam release from SG. RCS is supplied with coolant from inventory volumes in the primary circuits (emergency tanks) and SG is supplied by fire pumps.
Time margin to fuel damage: depends on initial levels of coolant at the time of event. If water level in the RPV was high and water from containment trays was provided, time to core uncover would exceed 13 days. In the worst case, if the RPV level was at the lowest operating value (0.5 m below the main flange) and the staff did not take any actions to make-up the RCS, there are about 3.5 hrs until the core uncover.

Containment integrity

In regime 6, the containment pressure boundary is disabled. At UHS loss the containment boundary does not have to be recovered, since steam from the RCS will leak through opened partition walls to the reactor hall. The containment integrity will not be endangered, but at the same time, it is not possible to prevent fully activity release into the power plant vicinity.

Spent fuel pool

The surrounding atmosphere (air) is the ultimate heat sink. Residual heat from spent fuel is removed in heat exchangers of SFP cooling systems to ESCW systems and from there via ESCW cooling towers to the

atmosphere. Loss of heat removal from SFP occurs only in case of all three ESCW systems failure. No back-up system is available for heat removal from SFP except for SFP cooling systems.

Considering the impacts on SFP cooling, total and immediate loss of ESCW pumps is an envelope case of UHS disruption (analyzed in SBO). Considering low probability of failure of all ESCW systems, the design scenario resulting in UHS loss due to raw make-up water loss was analyzed. Evaluation of safety functions was performed for SFP for the most conservative alternative of this scenario resulting after 72 hours in conditions requiring shutdown of all three ESCW systems.

After trip of all ESCW systems also SFP cooling systems capability is lost and thus, heat removal function in SFP is affected. Due to temperature increase in SFP, also sub-criticality of SFP fuel assembly will be decreased nevertheless the subcriticality is sustaining.

Spent fuel pool reactivity control

In the spent fuel pool sub-criticality is ensured by the boric acid concentration and by the spent fuel pool design itself, which does not allow formation of critical conditions in the spent fuel pool even after reduction of H₃BO₃ concentration to zero. After the ESCW failure, sub-criticality in the spent fuel pit is guaranteed. This characteristic is reached in EMO 1,2 by the grid mesh size in SFP – 162mm with hexagonal absorption tubes. In EBO 3,4 the calculations indicate that for zero boron and coolant boiling, criticality would be possible. However, during loss of UHS subcriticality in the SFP is managed by supplying borated coolant either from emergency tanks or from the bubbler trays and so the sub-criticality in SFP is guaranteed within the design scope.

Heat removal from the spent fuel pool

With regard to SFP cooling at evaluated scenario, reliable SFP cooling is ensured for 72 hours, as ESCW fails only after this time. After the ESCW system trip, a standard heat removal from the spent fuel pit through the SFP system coolers chilled by ESCW is not ensured. In relation to residual power of fuel in the spent fuel pool, which can range from 1.25 MW to 5 MW, and coolant inventory in the spent fuel pool before the event (14,46m/21,27m), there are time reserves according to the table (without operator's intervention). Assessment of time margins was performed separately for EBO 3,4 and for EMO 1,2.

EBO 3,4

After ESCW failure, only time limited alternative SFP cooling is available (SFP make-up from emergency tanks and SFP drain). At this mode of cooling, heat removal from SFP considering heat up of the inventory in one tank from 30°C to 60°C is provided from 2 to 8 hours depending on the power in SFP (minimally two tanks are at disposal in all regimes). For the SFP cooling, coolant inventory in containment trays could be used as well. If all 12 trays are used and heated from 40°C to 60°C, SFP cooling could be ensured in relation to power in the SFP for the next 5.6 to 22 hours.

Further heat removal from SFP after depletion of alternative cooling (together after 9.6 – 38 hours after ESCW trip) and coolant boiling in SFP, the heat can be removed only by SFP coolant evaporation. To maintain required coolant inventory in the SFP, it is necessary to ensure its make-up from other sources (fire pumps). Steam produced in SFP is to be removed to atmosphere.

Time margin to fuel damage in SFP depends on amount of spent fuel in SFP and initial coolant inventory.

Estimates without considering staff actions (without alternative cooling) are seen from the next table.

Alternative SFP cooling can extend these times by about 9.6 - 38 hours from ESCW failure, depending on the

power. Time margins given in the table start from the ESCW flow loss. For scenario with complete and immediate loss of make-up water supply additional 72 hours should be added.

Note: The estimates are conservative because the possibility to make-up service water system volume from circulating water pools is not taken into account. This could extend ESCW availability and SFP heat removal capability for additional 10-30 days.

All fuel is extracted to SFP, level in SFP 21.27m

Fuel power	Level	Boiling in SFP	Coolant evaporation above the fuel	Complete coolant evaporation under the fuel and temperature 1,200°C	Summary
4.87MW	21,27m	2hrs 48min	+20hrs 45min	+6hrs 52min	=30hrs 25min

Only spent fuel from previous campaigns in SFP, level in SFP 14.46m

Fuel power	Level	Boiling in SFP	Coolant evaporation above the fuel	Complete coolant evaporation under the fuel and temperature 1,200°C	Summary
1,25MW	14,46 m	5hrs 14 min	+37hrs 33min	+19hrs 15min	=62hrs 2min

Only spent fuel from previous campaigns in SFP, level in SFP 21.27m

Fuel power	Level	Boiling in SFP	Coolant evaporation above the fuel	Complete coolant evaporation under the fuel and temperature 1,200°C	Summary
1,25MW	21,27m	10hrs 55min	+127hrs 55min	+19hrs 15min	=158hrs 5min

EMO 1,2

Depending on residual fuel power in SFP ranging from 1.25 MW to 5 MW and thermal losses of working cooling pumps, the summary power is 1.3 to 5 MW. Despite further thermal load caused by the pump, the time to boiling in SFP is extended from 3 to 10 hours (depending on coolant volume and number of assemblies) thanks to related system pipelines and possibility to use stratified lower coolant volume in SFP (20m³). After reaching the boiling point, the pumps are assumed to be stopped; thus, the times for evaporation till fuel uncovering in SFP are identical with SBO – from 23 to 42 hours (without operator’s intervention).

After loss of ESCW, only alternative SFP cooling is available by its filling and drainage:

- Make-up from low pressure tanks by SFP pumps, auxiliary pumps, all bubbler condenser trays using available pump or by gravity to level +21m in SFP, thus extending the time to boiling by 5 hours for configuration without core off-loading (+14.7m);
- SFP drain through the overflow at +21.17 m to ECCS tanks or boron system tanks and to ensure back flow by pumps or by gravity. Use of coolant inventory heating will extend the time to boiling in SFP and can be used for temperatures from 40°C (60°C for LP ECCS) to 90°C. SFP cooling will extend the time to boiling by 3 - 6 hours depending on power in SFP and using 300 m³ (three containment spray system channels or 2 LP-tanks system).

Time to SFP boiling:

	IE – heating to the boiling point		Level increase to +21m		SFP drainage and heating LP ECCS or BC 300 m ³		Total	
Level	+14.7m	+21.17m	+14,7m	+21.22m	+14,7m	+21.22m	+14,7m	+21.22m
Heating time	11 h	3 h	5 h	0 h	6h	3h	22 h	6 h

Coolant evaporation from SFP

Further heat removal from SFP after exhaustion of alternative cooling (6 – 22 hours after UHS) and SFP heating to the boiling point can be ensured only to the detriment of coolant evaporation from the SFP. To maintain required coolant inventory in SFP, it is necessary to ensure its make-up from other sources (LP- tanks, bubbler condenser trays, CFT, fire pumps). SFP make-up need per unit at heat removal from SFP by coolant boiling ranges from 2 m³/hr (power 1.25 MW) to 8 m³/hr (power 5 MW). Steam generated in SFP is removed to the atmosphere via the reactor hall.

Resulting times without staff intervention

Event UHS	Fuel assemblies in both racks +21.17 m/ 4.8 MW Time [hrs]	Fuel assemblies in basic rack only +14.46 m/1.26 MW Time [hrs]
START OF EVENT	0	0
Reaching of saturation limit – boiling in SFP	3	11
Exposure of stored fuel assemblies	23	42,5
Damaging of fuel assemblies 1,200°C	31	63

Resulting times with staff intervention, the table shows how much the time will be extended

Event UHS	Fuel assemblies in both racks +21.17 m/ 4.8 MW Time [hrs]	Fuel assemblies in basic rack only +14.46 m/1.26 MW Time [hrs]
Level increase in SFP	0	5
SFP drainage and heating LP ECCS 300m ³	3	6
BCT / LP ECCS inventory 50% (600/300) evaporation	112	450
Filling by fire truck	unlimited	unlimited

5.2.3.1 External actions foreseen to prevent fuel degradation

External activities have to focus on ESCW make-up, demineralized water make-up and supply logistics. There are several alternative methods for compensation of ESCW circuit water losses either from internal or external sources. The basic time reserve till initiation of ESCW make-up resulting from water inventory in ESCW basins is 72 hours. Another internal water sources in the NPP (CW cooling tower basin and supply channels) contain water for more days depending on the event scenario (see chapter 5.1.3). This water can be pumped to ESCW basins by SCW pumps or by mobile pumps. SCW system is normal operational system without reinforcement against beyond-basis external events and without seismic classification. Water make-up by SCW pumps can be initiated within 1 hour; make-up flow rate is higher than needed for level maintaining. ESCW make-up from CW basins by mobile pumps was also trained during the stress tests using submersible pump supplied from electric power supply and floating pump with own petrol engine. It took 30 minutes to install the pump and start its operation from notification of the request.

In EBO3,4 ESCW can be also supplied from V1 NPP using normal operational systems without seismic classification. Water make-up of ESCW pools from V1 NPP can be initiated within 3 hours; make-up flow rate is higher than needed for level maintaining in ESCW pools. In the ultimate case, water to ESCW can be provided by mobile means (truck cisterns or helicopters) from water reservoirs in NPP vicinity. Water make-up from external

sources using mobile means was tested during emergency drills in 2011. Make-up of ESCW pools by these means can be initiated within 4 hours.

5.2.3.2 Time available to recover one of the lost heat sinks or to initiate external actions and to restore core and spent fuel pool cooling before fuel damage: consideration of various examples of time delay from reactor shutdown to loss of normal reactor core and spent fuel pool cooling condition (e.g. start of water loss from the primary circuit)

Times for individual states are given in the following table; description including analysis is in chapter 5.2.3 (data for EMO 1,2 are provided):

Time available to recover one of the ultimate heat sinks

	Initiating Event	ESCW loss - time	Time between ESCW loss and core melting	Total time
1.	Raw make-up water loss without internal and external intervention	72 hours / 3 days	341 hours /14.2 days	413 hours / 17.2 days
2.	Raw make-upwater loss with internal intervention – available CW	12 – 33 days	341 hours /14.2 days	26.2 to 47.2 days
3.	Raw make-upwater loss with internal and external intervention	unlimited	-	unlimited
4.	ESCW loss	X	341 hours /14.2 days	341 hours / 14.2 days
5.	ESCW loss + unavailability of demineralized water	X	5,5h SG+16h FWT + 3h HA +3h core	27 hours
6.	ESCW loss + unavailability of demineralized water and FWT (very low probability – combination of three failures)	X	5,5h SG +2.7h HA + 2.9h core	11.1 hours

5.2.4 Conclusion on the adequacy of protection against loss of ultimate heat sink

The resistance of SFP in loss of UHS conditions (loss of make-up raw water) is adequate.

1. The nominal water volume of ESCW ensures at least 72 hrs of ESCW availability after loss of raw make-up water.
2. Additional water inventory available on the site in CW pools provide for additional 10-30 days of ESCW availability.
3. After loss of all ESCW trains the basic design provides minimum margin of 200 hrs to fuel damage in reactor (for regime 6 approx. 140 hrs)
4. After loss of all ESCW trains the basic design provides minimum margin of 30 hrs to fuel damage in SFP (conservative estimate without operator intervention).

5.2.5 Measures which can be envisaged to increase robustness of the plants in case of loss of ultimate heat sink

Evaluation of safety margins of V213 design in the case of UHS loss proved the plant design ability to ensure protection of safety barriers for given type of events during considerably long time, thus providing sufficient time margin for accident management interventions to recover UHS. Despite the robustness of power plant design, its safety can be improved by the following modifications:

- To provide for additional mobile high-pressure source of SG feedwater supply for each unit, and to ensure the mobile source supply logistics.
- To provide for mobile pumps for ESCW make-up from CW
- To provide analysis of RCP seals' behaviour at long-term failure of cooling (more than 24 hours)
- To establish the logistic system for provision of emergency feedwater to suction of mobile emergency pumps from external water sources.
- To modify connection of emergency mobile source to EFWS suction and discharge to be accessible from level 0 m, beyond the anti-freezing barrier (in EMO) in order to ensure emergency mobile supply in cases of internal and external floods and fires
- To construct a fixed line for maintaining the coolant inventory in SFP from a mobile source (fire pumps)
- To prepare measures for steam removal from the SFP in case of coolant boiling.

5.3 Loss of the primary ultimate heat sink, combined with station black out (see stress tests specifications)

5.3.1 Time of autonomy of the site before loss of normal cooling condition of the reactor core and spent fuel pool (e.g. start of water loss from the primary circuit)

Since in V213 design ESCW pumps are supplied from the emergency power supply which is unavailable after SBO, SBO always results with certain time delay in the loss of UHS. It means that consequences of this combination of events are the same as of SBO alone. See Chapters 5.1 and 5.2.

5.3.2 External actions foreseen to prevent fuel degradation

Since in V213 design ESCW pumps are supplied from the emergency power supply which is unavailable after SBO, SBO always results with certain time delay in the loss of UHS. It means that consequences of this combination of events are the same as of SBO alone. See Chapters 5.1 and 5.2.

5.3.3 Measures, which can be envisaged to increase robustness of the plants in case of loss of primary ultimate heat sink, combined with station black out

The measures proposed in Chapters 5.1.5 and 5.2.5 deal also with combination of UHS with SBO.

6 Severe accident management

Severe accident management is arranged for all operating units in a similar way, both from viewpoints of relevant technical means as well as organizational measures, with few exceptions related to different features of the respective site. For MO3,4 currently under construction it is also planned to implement the similar arrangement. The text below is therefore valid for all units, with comments on differences between the units where appropriate.

6.1 Organization and arrangements of the licensee to manage accidents

Emergency planning and preparedness (EPP) belongs to the main responsibilities of NPPs. EPP process is completely provided and managed by professional departments of the specific plant based on the process documentation included in the integrated management system IMS. IMS clearly defines requirements and responsibilities for individual parts of EPP.

EPP is implemented in line with international requirements and IAEA methodologies. The system complies with all Slovak legislative requirements, in particular with the Act No.541/2004 on the Peaceful Use of Nuclear Energy (Atomic Act) and on amendment and alterations of several acts and Decree No. 55/2006 on details concerning emergency planning in case of nuclear incident or accident. The objective of EPP is to assure technical, personnel and documentation preparedness of plant staff and involved external organisations to efficiently manage extraordinary events. This strategic objective is in compliance with SE, a.s. policies at level of individual plants transformed to specific long-term and short-term objectives and tasks. EPP of nuclear units is integrated into the national emergency response organization of the Slovak Republic (see the Figure 20) with the Slovak government being responsible for emergency preparedness at the national level.

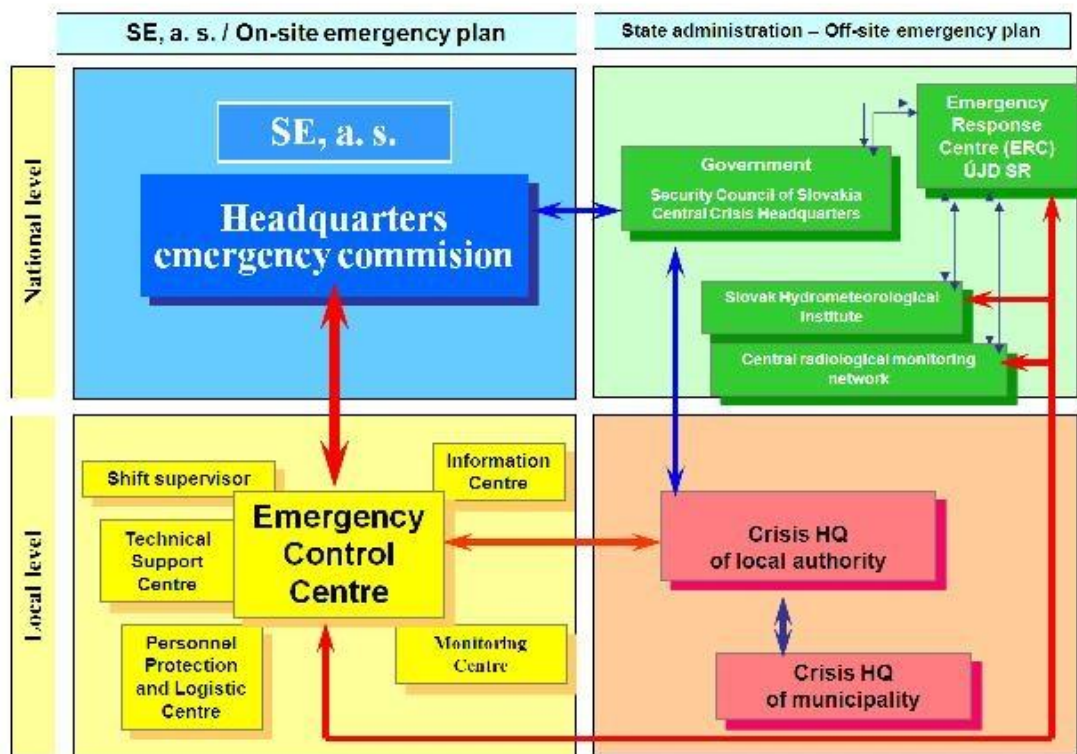

Figure 20: National emergency response organization of the Slovak Republic

The proposed emergency preparedness strategy is based on development of any event with potential external impact, with set of actions depending on its significance. The emergency response is organized in two basic phases. In the first phase of event, measures are adopted to manage the accident from the main control room (MCR) of the affected unit with actions performed by standard shift staff. In the second phase, management of the event is taken over by the Emergency Commission (EC) which should convene in the Emergency Control Centre (ECC) on site within 60 minutes during off-hours and within 20 - 30 minutes during working hours after the activation signal. Under specified conditions the EC convenes in the Back-up Emergency Centre in Trnava and Levice respectively.

EPP of each of the NPPs reflects relevant features of the specific site, including distribution of the population around the site. Bohunice site is located in vicinity of the village Jaslovske Bohunice, approx. 12 km from the city Trnava and approx. 14 km from the city Piestany. About 285,000 people live in the zone with Emergency Planning Zone with 21 km radius. Similarly, Mochovce site is situated close to village Mochovce (village inhabitants moved out before construction started), approx. 12 km from the city Levice and approx. 14 km from Zlate Moravce and 11 km from Vrable. About 159,000 people live in within the Emergency Planning Zone with 20 km radius.

In the Emergency Planning Zones of EBO and EMO with 21 km and 20 km radius respectively the off-site emergency plans are established. Radiological criteria (intervention levels) for introduction of emergency protective actions are defined in the SR Government Decree No. 345/2006 Coll. Off-site emergency plans are consistent with the On-site emergency plans of the NPP.

The Emergency Planning Zone is subdivided into 16 sectors. For the emergency response needs in the case of a specific accident the plant surrounding is split into the following areas:

- Exclusion zone
- Precautionary Action Zone
- Urgent Protective Action Planning Zone

Adequate measures in line with ERO procedures and documentation are taken in these zones based on the accident predictions. Emergency zones with evacuation routes are shown for both sites in the Figure 21 and Figure 22.

.



Figure 21: Map of Bohunice site showing the zones and evacuation routes

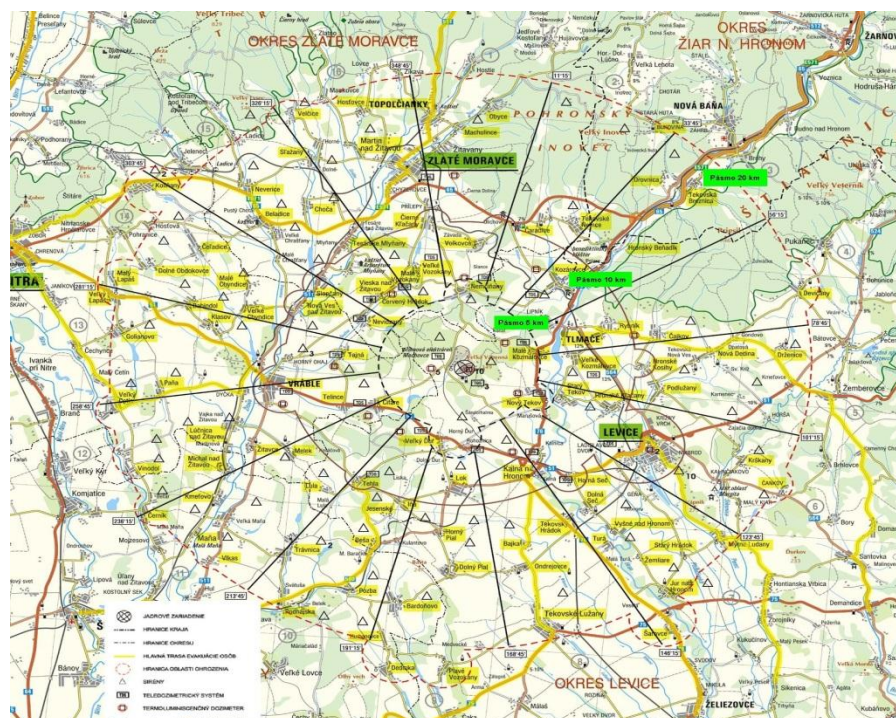

Figure 22: Map of Mochovce site showing the zones and evacuation routes

6.1.1 Organization of the licensee to manage the accident

6.1.1.1 Staffing and shift management in normal operation

Shift operation management

Operation of both units for each of the plants is provided by the plant employees in shift operation. Minimal number of shift personnel and its professional composition is approved by UJD SR. The shift supervisor (SS) has full authority and responsibility for the safe operation. He directly manages reactor unit supervisors (RUS), shift foremen of RCS, SC, electric part, technical workers in water management system, I&C, radiation monitoring and chemistry technician.

The main control room (MCR) is the most important working place in the NPP. There is a temporary working place in the MCR for the SS for his activities during extraordinary operational events.

Emergency control room (ECR) is a back-up working place in case of inhabitability of the MCR or if the reactor and emergency systems cannot be controlled from the MCR.

The shift staffing includes also other departments:

- Physical protection staff – provides for physical protection and operation of the physical protection control centre (PP CC), availability of escape routes from endangered objects and areas, tracking of individuals on the site.
- Plant fire brigade (PFB) which is in charge of readiness of fire fighting equipment, operation of the fire announcing centre and announces fire alarm. Shift PFB has staff in the following positions: Shift commander PFB (1), fire squad commander (2), fireman rescuer (13 in EBO 3,4, and 9 in EMO 1,2), fireman – operator of the fire announcing centre (1).

6.1.1.2 Measures taken to enable optimal intervention by personnel

There are instructions and procedures in place for the staff for management of emergency situations.

The basic ERO principles and procedures are covered by the on-site emergency plan (on-site EP), emergency operating procedures (EOP), emergency instructions for implementation of on-site EP, severe accident management guidelines (SAMG) and related plant technical documentation. These procedures define responsibilities and competencies of the plant staff and ERO members. EOP and SAMG are described more in detail in section 6.1.1.5.

Non-technological intervention groups – PFB, PP, police corps are promptly available on the site and are used for rescue, localization and recovery activities immediately after the event. Protection of intervening personnel with regard to irradiation and contamination during emergencies is one of the most important parts of emergency response. After event announcement, measures for protection of plant employees and other persons on the site are implemented based on the event significance and pursuant to ERO documentation.

Short-term civil protection (CP) assembly points

CP assembly points situated in plant premises serve for assembly of plant staff. These facilities provide for conditions for short-term stay if using personal protective equipment. All CP assembly points are equipped with basic personal protective equipment in quantity corresponding to the capacity so that enabling evacuation from the assembly points to evacuation transportation means. CP assembly points are also equipped with communication means, portable dosimeters for measurement of surface contamination and dose rate, sanitary

material and potable water. Total capacity of assembly points is about 500 people in EBO 3,4 and 800 people in EMO 1,2.

Permanent CP shelters

Permanent shelters are used for sheltering employees and rescue staff. They also serve for distribution of individual protection means and special equipment for rescue teams. Permanent CP shelters meet conditions for long-term stay of rescue staff, in compliance with Regulation of MV SR No. 532/2006 on details for assurance of building and technical requirements and technical conditions of CP facilities. Capacity of shelters is 600 people in EBO 3,4 and 1,200 persons in Mochovce.

CP shelters are equipped with filtering and venting equipment. They are also equipped with water system with separate storage tanks for service / potable water, with emergency illumination system, decontamination part, communication means and manual dosimeters for surface contamination and dose rate measurement. Sanitary material, bottled water and PPE are prepared in the shelters.

Protection of intervening personnel within ERO

ERO centres

For ERO activities the site is equipped with facilities for emergency response with tools for detection and evaluation of emergency events and for logistics.

Unit control rooms

Main and emergency control rooms situated in the reactor building at +9.6 m level are the primary centres for emergency response management. They have sufficient illumination, they are vented and air-tight; they assure stay for the time required for control of plant during accidents without overexposure of personnel. Emergency control rooms are available in case of evacuation from MCR with capability to provide for fundamental safety functions. The MCR and ECR are located in separate fire sections and they are over pressurized to prevent penetration of hazardous substances. MCR and ECR are equipped with filtering and venting devices with filters intended for capture of radioactive substances. The control rooms are equipped with communication means (telephone, fax, radio station, public address system), water reserves and PPE.

Emergency Control Centre (ECC)

There are emergency control centres with necessary supporting facilities established on each site. The centres are located in resistant and hermetic shelters and meet criteria set by the Notification of MV SR No. 532/2006 on details for provision of civil-technical requirements and technical conditions for CP facilities. They are seismically resistant and protected against penetration of radioactive substances in case of severe accident or other dangerous substances.

Neither MCR, nor ECR enable long-term stay of personnel in case of a severe accident. Therefore EBO3,4 ECC building that was constructed as part of the SAM implementation project, is equipped with workplace of operational staff of both units MCR3, MCR4 providing conditions for long-term stay. Similar workplace will be established in the premises of TSC of EMO1,2 within the SAM project.

ECC has means for communication with other involved working places involved in emergency response. It is equipped with technological information system providing operational data from the both reactor units, TDS, on-line transfer of technological and radiation data to UJD SR, ESTE software for determination of the source term, event classification, prognosis and evaluation of accident consequences. Telecommunication technology

consists of telephone lines with an access to public telephone network, emitters for use of mobile phones, fax machines, radio and radio-communication network. Members of the Emergency Commission have at their disposition operational documentation for management of emergencies, emergency operating procedures, emergency instructions and related operational plant documentation.

ECC contains also a workplace for MCR operation staff and SS in duty which can be used in case of a severe accident. This workplace will be eventually completed within the SAM project.

ECC provides conditions for long-term work of the EC for at least 5 days. The ECC is usable also in case of extreme natural conditions with access either by external roads (provided that they are open to traffic) or by alternative transport out of road means (armoured personnel carrier).

Back-up ECC

It serves as the back-up ECC workplace instead of ECC in case of unfavourable radiation or weather situation on the site. It is situated in off-site radiation monitoring LRKO centre in Trnava and Levice, respectively and enables short-term stay of EC members. Back-up ECC has available on-line information from the Technological Information System of both units and from the teledosimetry system, ESTE software for determination of the source term, event classification, prognosis and evaluation of accident consequences.

It also provides the connection means (phone, fax, radio stations) and technical documentation. The building has autonomous electric power supply. Radiation situation monitoring uses portable dosimeters for dose rate and surface contamination measurement. Considering the distance from the site, the facility is not protected against penetration of radioactive and dangerous substances and it is not seismically reinforced.

Monitoring centre – external evaluation centre

The centres are situated in the off-site radiation monitoring centre in Trnava and Levice, respectively. They serve for monitoring, assessment and forecasting of radiation situation in the respective site and in its vicinity. The centres are equipped with TDS, ESTE software for specification of the source term, forecast and assessment of accident consequences, and GIMSOR and back-up RMMS application for monitoring the movement of monitoring vehicles. LRKO is equipped with communication means (telephone, fax, radio stations) and documentation for management of emergencies, for rescue staff, potable water and PPE. In case of power supply loss, the building is equipped with independent emergency power supply – diesel generator isolated from the external grid. The off-site radiation monitoring centre building fulfils only basic functions for short-term stay of persons. The building is without filtering and venting equipment, i.e. it is not protected against penetration of radioactive and hazardous substances, it is not seismically reinforced and is without water inventory for decontamination of rescue personnel. The building does not meet conditions for long-term stay in case of an accident or under extreme weather conditions.

Personal Protective Equipment

Personal protective equipment (PPE) include means for protection of breathing ways, eyes and body surface to assure adequate protection against radiation effects. These means are available for all people on the site.

Continuous operation workplaces – plant operation, PP CC, PFB, SE Protection & Security and Fire Protection, shelters and civil protection assembly points are equipped with protective masks with filters for hazardous and radioactive substances, with personal protective packs, iodine pills and personal dosimeters. Shift staff and ERO rescue squad members participating in management of the event in contaminated area have special means, including special protection suit and breathing apparatus. If necessary, staff intervening in the controlled area is

equipped with breathing apparatus. Use of special PPE enables the staff and persons in duty to stay in contaminated environment and to perform required technological and rescue works.

Water Needed for Operation of the Access to Controlled Area

Water reserves needed for the operation of the controlled area access compartment and for decontamination are available. In EBO 3,4 water reserves are stored in tanks of the water system with the total volume of 30,000 litres. In EMO1,2 water is stored in tanks with 3,200 litre volume. The tanks are permanently filled with water and prepared for immediate use. Water quality is regularly inspected.

For decontamination, there is a storage service water tank with volume of 11,000 litres installed in the EBO3,4 ECC. The tank is permanently filled with water and water quality is regularly checked. Water reserve for decontamination 2,000 l/day complies with legislation and it is sufficient and independent from the service water distribution system in EBO. As service water reserves, PFB means (4 PFB cisterns, with the total volume of 22,900 litres), cooling water, ESCW and clear water inventories may be used.

In EMO1,2 another option to ensure water needed for decontamination is to use firewater inventory usable through PFB means with the volume of 36,000 litres. The operational building ground floor is provided with couplings for connection of fire hoses from discharge of truck cistern pump. Considering needs of service water for decontamination (2.5 litre – hands, 40 litres – shower), and utilisation of water pumped from the truck cisterns, the inventory serves for about 922 persons/day.

Another option is to use potable water sources filled in vessels in shelters.

Potable water and food for intervening staff

EBO3,4 has instantly available water inventory in shelters and CP assembly points, operational areas, LRKO and gatehouses with volume approx. 645 litres. Additional water is available from the plant buffets and canteens – approx. 900 litres. EBO3,4 ECC is provided with potable water in bottles – 90 litres. After completion of the potable water system in EBO3,4 ECC and considering potable water needs in compliance with the legislation, 3 l per day and person, the potable water reserve will be sufficient for 3 days. Frozen meals for shift operation are ensured in the EBO3,4 canteen. The existing frozen meals stock is about 500 pieces. The next stock of meals, about 50 pieces, is in EBO3,4 ECC structure; it is intended in particular for EBO3,4 EC members and MCR operation staff.

In EMO 1,2 instantly available water inventory in shelters and CP assembly points, operational areas, LRKO and gatehouses is 552 litres. Water available from the plant buffets and canteens is ~ 1,500 litres. EMO1,2 ECC is provided with potable water in bottles 165 litres. Another potable water inventories are in vessels in shelters with the volume of 41,950 litres. The vessels are normally empty. When shelter team members are called to the shelter and a classified event is raised, the team will fill in the vessels by opening main valves. Considering recommended potable water needs in compliance with the legislation (3 litres person/day), the aforementioned inventory is sufficient to assure drinking regime of 1,000 persons for about 14 days. If only bottled water is at disposal, the water reserves will guarantee the drinking regime for 739 persons for one day. Frozen meals for shift operation are ensured in the EMO1,2 canteen. The existing frozen meals stock is about 3,000 pieces. If needed, packed meals in buffets may be used as well.

On-site radiation situation monitoring and radiation protection of workers

Information of radiation situation in operational and other selected areas is obtained by the radiation monitoring system and TDS detectors. The site territory is equipped with detectors for dose input measuring on operational buildings (5 or 6 places). Measuring in other areas is performed by portable instruments.

Dose rate is measured continuously on CP assembly points, in CP shelters, back-up ECC, MCR, RMCR, SS, PP CC and the gatehouse. Workers coming to the plant for intervention or shift change receive their PPE in the main gatehouse. External units of fire brigade, medical service, police corps, evacuation vehicle drivers and others are equipped in the same way. PFB has its own independent dosimetry equipment for monitoring of received doses.

In case of a radiation accident, there is a risk of overexposure for employees performing rescue and localisation works (intervention teams). Exposure limits for such situations are determined in line with relevant Slovak legislation.

6.1.1.3 Use of off-site technical support for accident management

The method and extent of cooperation with external state authorities involved in emergency planning is determined by the valid legislation (organizations involved are UJD SR, Ministry of Interior of the SR, Ministry of Health of the SR - Public Health Authority of the SR, Civil Protection department and regional directorate at the county office in the emergency planning zone).

To ensure professional technical and personnel assistance in case of accidents, co-operation agreements have been concluded with qualified external organizations, in particular with VUJE, a. s., and AB Merit. In Bohunice, the company SE, a. s., assures specialized services for area monitoring by emergency monitoring groups, guarding services and decontamination services for accidents.

Co-operation agreements were concluded with external organizations in the area of complementary radiological monitoring of NPP vicinity, medical services, fire services etc. An agreement on mutual cooperation was also signed with the County Directorates of the Fire and Rescue Corps (Trnava and Levice) for fighting fires, elimination of consequences of accidents, natural disasters and other extraordinary events.

Bodies and organizations involved in technical support have their own equipment and employees trained for this purpose.

Headquarter of SE,a.s. has established contractual relations with hospitals selected by the Ministry of Health of the SR for their preparedness to provide specialized medical services in case of extraordinary events in NPP or during radioactive material transport. Similarly SE, a.s. has an agreement with the Ministry of Interior of the SR (Agreement on mutual cooperation on provision of the civil protection information system and on provision of organizational units of the Fire and Rescue Corps) for provision of aid by the Corps to SE, a.s. plants at execution of activities needed for control and removal of consequences of fires and nuclear accidents, at recovery of affected area, including on- site support of these plants.

6.1.1.4 Dependence on the functions of other reactors on the same site

Both NPPs EBO3,4 and EMO1,2 are designed and operated as twin units. On the level of the design basis and beyond design basis all required safety functions are provided by unit specific equipment without the need for the supporting functions from the neighbour unit. The only relevant safety related interconnection is within the Essential Service Water System and Emergency Feedwater System where part of systems (parts needed for raw make-up water, tanks and part of the pipelines are common for both units). In general, partially shared or common systems are exclusively dedicated for normal operation (cleaning of media, drainage systems tanks,

auxiliary operational systems). There is a possibility to share resources (media, coolant) between units through supporting systems pipelines but this feature is considered only as a contingency for very low probability beyond design basis situations.

Design modifications for severe accidents are designed for each particular unit with the exception of tanks of SAM external water source and emergency power supply (SAM DG) which are common for both units. The adequacy of such solution was approved by the SAM project principles where the severe accident was anticipated in only one unit. Appropriateness of such solution may be reconsidered in the future.

6.1.1.5 Procedures, training and exercises

Symptom oriented EOP and comprehensive SAMG consistent with adequate hardware provisions for execution of the required actions represent essential components for procedural support of accident management and for decisions taken by MCR and ERO groups.

Implementation of symptom oriented EOP

Development of the severe accident and beyond-design basis accident management tools is a controlled process implemented in stages since 1995. Symptom-oriented EOP covering design basis and beyond-design basis conditions (up to the core melt) were fully implemented in both in EBO3,4 and EMO1,2 in 1999 (for events initiated during power operation) and in 2006 (for events initiated at shut-down reactor or in the SFP). This was the first necessary step allowing development of the severe accident management programme.

Development and implementation of symptom oriented SAMG – SAM project

After completion of EOP the next objective was to extend AM to mitigation of severe accidents. The effort started by the complex analytical project PHARE 4.2.7 a Beyond Design Basis Accident Analysis and Accident Management, implemented in 1996-1998. Main objectives of this project were analyses of VVER 440/213 type NPP response, identification of containment failure mechanisms under severe accident conditions and review of applicability for V213 containments the basic strategies identified for Western containment types. This project was followed by two other projects – PHARE 2.06 Analysis of the Need and of Alternatives for Filtered Venting of Containments and PHARE 2.07 Hydrogen Control during Severe Accidents, which were finished in 1999. These three projects jointly performed by Westinghouse and research institutes from Slovakia, Czech Republic and Hungary represent a comprehensive study of vulnerability of V213 units in severe accident conditions and a preparatory phase for implementation of AM in severe accidents initiated by internal events.

Based on analyses from the aforementioned projects, the probabilistic PSA Level 2 study for EBO3,4 was prepared in 2000 as one of basic inputs for development of plant specific severe accident management guidelines (SAMG).

SAMG were prepared in co-operation with Westinghouse in the common EBO3,4 and EMO1,2 project during the period from 2002 to 2004. Unlike similar projects in Western NPPs it was decided to mitigate or eliminate all identified containment vulnerability mechanisms by suitable modifications or extensions of V213 basic design. Proposals of such key modifications have been prepared in several stages and several analytical projects were implemented for verification of feasibility and of efficiency of developed strategies.

The project for implementation of modifications needed for severe accident management was proposed in compliance with updated requirements of Slovak legislation in 2006 - 2008. The modifications were reflected in the Integral Corrective Action Plan from periodic safety assessment of EBO3,4 and EMO1,2 (completed in 2008 and 2009, resp.) approved by UJD SR decision permitting the operation for next 10 years following the Periodic

Safety Review. The SAM implementation project was initiated in 2009 as the common EBO3,4 and EMO1,2 project with deadline in 2013 in EBO3,4 and 2015 in EMO12.

In the initial stage of the SAM implementation project a safety concept was prepared defining overall safety objectives, the project scope and design principles, design basis for newly installed and modified equipment. The safety concept was approved by UJD SR.

Modifications and changes within the project are being implemented during unit outages under strict quality management rules. Installations and project related activities are assigned to the following groups:

- Modifications related to controlled primary circuit depressurization ability
- Modifications needed for reactor cavity flooding and external reactor vessel cooling
- Modifications related to hydrogen management in the containment
- Installation and improvement of I&C needed for severe accident management
- Modifications enabling prevention of excessive under-pressure in the containment
- Modifications enabling coolant make-up from external source to the reactor and spent fuel pool and reliable, time limited containment spraying from the external source
- Modifications enabling coolant make-up to the reactor cavity, spent fuel pool and external source tanks using mobile source connected to the external connection point on walls of the reactor building and auxiliary building.
- Installation of independent dedicated 6kV DG and relevant electric devices enabling supplying SAM consumers and selected critical unit consumers under SA conditions in case of complete loss of power supply.

The project also includes preparation of documentation related to the licensing basis (complete deterministic and probabilistic justification), SAMG update according to real project situation after installation of modifications and of new equipment, MCR staff training and training of specialized ERO teams, and SAMG validation.

Long-term heat removal from the containment after severe accident is solved by recovery of operability of design unit equipment (containment spray system). A study was prepared for use of alternative systems and feasibility study for heat removal recovery from the containment.

Considering the SAM implementation the project focuses on reinforcement of the in-depth protection level 4. Requirements for design principles were defined during the project preparation that must be consistently applied to specific hardware solutions. These principles comply with currently nationally and internationally valid safety requirements. In line with valid approaches to severe accident management at the time of SAM project initiation, the project is based on assumption of severe accident occurring on one of two units only. SAM modifications include active components assigned to a specific unit; passive components (tanks, pipes, etc.) and consumables (coolant, fuel, etc.) can be used for both units.

Long-term aspects of severe accidents can be managed by the existing systems. Any survived equipment for normal operation, safety systems assigned for management of design-basis accidents or severe beyond design-basis accidents is used. It is possible to use equipment common for two units or interconnection between them.

Organizational provisions for use of the procedures and the guidelines

Procedures and guidelines, emergency instructions and other documentation are available in working places of intervening shift. The staff is trained for use of procedures in regular intervals. Relevant documents clearly define responsibilities and rules of use. The main documents dealing with extraordinary events include:

- Abnormal operating procedures
- Emergency operating procedures
- Severe accident management guidelines
- Fire procedures
- Emergency instructions.

Abnormal and emergency operating procedures are used by operators in MCR in case of failures of NPP components and systems including accidents and external threats. The procedures are specific for the given unit and aim at prevention of the core damage. MCR operational staff strictly follows EOP.

When the EC is called and TSC is activated their members evaluate and monitor accident progression, fulfilment of critical safety functions and provide advice for actions. For these activities the TSC is equipped also with a special document (the TSC manual).

In case of transition from a design basis accident to a severe accident, actions of EOPs are not applicable and further decisions are made using SAMGs. Decision on transition from EOP to SAMG is based on specified criteria. Overall SAMG goal is to maintain integrity of the containment and to prevent or mitigate releases of radioactive substances to the environment.

NPP have developed the staff training plan ensuring that all involved plant and SE, a.s. employees are adequately prepared for execution of required measures. Special preparation, exercise and training are provided for the emergency response organization members.

The training regarding the emergency plan forms part of the induction training of all newly hired employees. In the subsequent period, employees are included in the periodical training programme for detailed familiarization with ERO organization. The training also covers the principles of radiation protection.

Training of ERO members

Staff training is the introductory stage of emergency preparedness. General theoretical preparation in form of induction, introduction and periodical training is obligatory for all persons working on the site. Moreover, staff assigned to ERO is trained for specific activities corresponding to their assignment. Theoretical preparation is followed by practical exercises.

In order to maintain necessary skills and to follow software and hardware modifications in the emergency and support centres, the training includes two exercises of ERO emergency shifts in ECC, TSC, SLOP, MS, IS per year. The training can be combined with emergency drills or testing of technical means. Connection and communication, fire suppressing, radiation situation monitoring, evacuation from endangered areas are examples of such exercises. Shift intervention team is trained in activities aimed at medical assistance, PFB assistance and preparation of CP shelter. Various intervention groups and police special units have preparation programmes associated with their specific activities. They are also trained as members of ERO. Firemen and operational staff exercise activities associated with e.g. emergency make-up of steam generators or supply of water at simulated raw water loss by mobile means.

MCR operators pass regular training and verification in line with operator's license. They are trained at full-scope simulator.

Exercises of members of ERO and EC (all shifts) are performed twice a year at least. Simulator training is performed together with MCR staff according to the annual time schedule.

Plant exercise including ERO departments and other persons working on the site is performed once a year to demonstrate emergency preparedness in line with the Emergency Plan.

Complex exercise including external organizations and authorities is performed once per three years.

Education, training and exercises of ERO staff are regularly supervised by UJD SR during inspections.

6.1.1.6 Plans for strengthening the site organization for accident management

Emergency response organization (ERO) considers wide spectrum of postulated events from those with negligible impact on the environment up to severe accidents. Classification of events into three severity levels is defined by the regulation of UJD SR No. 55/2006 Coll. on details concerning emergency planning in case of nuclear incidents or accidents:

1. Level 1 – ALERT - a situation where fulfilment of safety functions is endangered or violated, safety barriers are damaged or non-functional, there is a risk of radioactive substances release or they have already released, which can lead or leads to an unpermitted exposure of people in nuclear installation structures, and there is a risk of radioactive substances release out of the structures in case of an adverse development of the situation.
2. Level 2 – ON-SITE EMERGENCY – a situation which can lead or leads to radioactive substances release out of the nuclear installation structures and on the site.
3. Level 3 – OFF-SITE EMERGENCY– a situation which can lead or leads to serious radioactive substances release to the surroundings of the installation.

Besides technological and radiological events, also large natural catastrophes are considered (earthquake, high windstorms, storms, thunderbolts, flooding, extreme cold) together with other external impacts (external grid failure, lack of cooling water from external sources, aircraft crash on important objects).

In case of an emergency event classified at level 1, 2 or 3, its management is performed by the plant Emergency Response Organization (Figure 23). The director of the plant is a designated head or ERO delegating his rights to the shift supervisor in duty and to EC shift manager. Decisions taken by EC are binding for all plant and SE, a.s. employees and for all persons on the site. SS is permanently responsible for performance of all interventions in technological objects.

Emergency Response of NPP

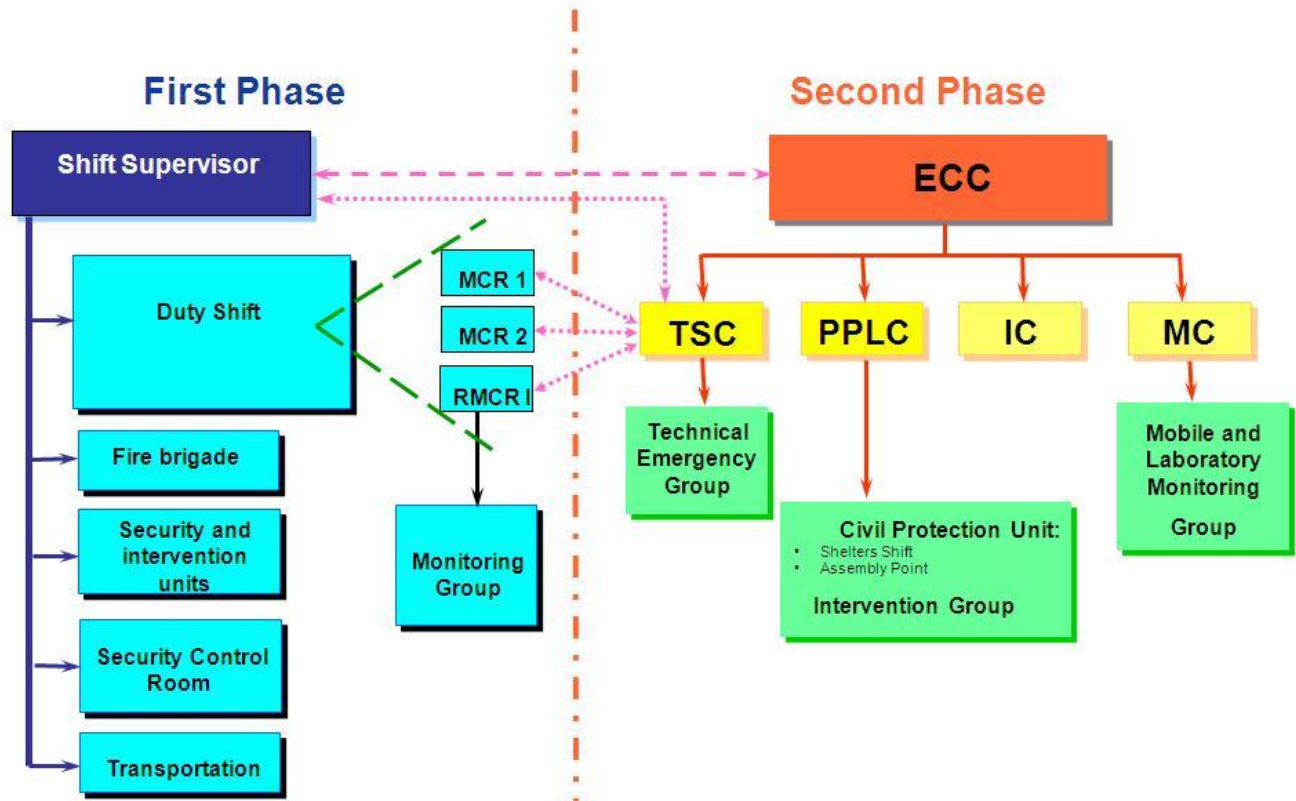

Figure 23: Two phases of the Emergency Response

The emergency response is performed in two phases according to the Figure 23.

Emergency response – phase 1

In case of an event, the shift supervisor takes over management of ERO. The first phase of ERO is provided by the shift personnel headed by the SS on duty. Activities in this phase focus on stabilization of situation on the unit and on the site, and on initiation of necessary protective measures on the plant territory and its vicinity.

At the beginning SS on duty makes an initial assessment and classification of the event, ensures announcement of event on the site or in vicinity, activates required ERO components, in particular the EC and informs the SE, a.s. emergency service. He also ensures implementation of immediate protective measures for employees and, if needed, also for population in the plant vicinity, in particular warning, notification of respective bodies and organizations (UJD SR, MV SR, UVZ SR and crisis staffs in regions in the plant emergency zone).

Emergency response – phase 2

Phase two is initiated at the moment when EC is gathered in the emergency control centre (ECC) and ERO support centres and coordinates activities of individual ER components from there. In phase 2, management of all on-site activities is taken over by the Emergency Commission.

Main tasks of the EC are:

- Management and coordination of all activities according to the IEP;
- Management and coordination of all ERO components;

- Announcement of protective measures for persons on the site;
- Approval of emergency doses for rescue team members;
- Delivery of the initial report and subsequent reports to regulatory and supervisory authorities including proposal of protective measures for the plant surroundings.

EC members are subdivided into the working groups located in different premisses as follows:

Emergency Control Centre (ECC) – a workplace for the team coordinating work of the ERO groups at performance of measures mitigating incident or accident consequences

Technical support centre (TSC) – workplace for support of affected unit is MCR personnel. It performs analysis of status of the affected unit and determines the event prognosis, and manages MCR activities at severe accident pursuant to SAMGs

Personnel protection and logistic centre (PPLC) – workplace for coordination of rescue, localization, removal and recovery works and for preparation and implementation of adopted protective measures

Monitoring centre (MC) – workplaces (both on-site and off-site) performing monitoring and prognosis of radiation situation, estimation of on- and off-site doses, preparation of input information for determination of protective measures both on- and off-site

Information centre (IC) – workplace for preparation of input information for informing public and media and SE, a.s. groups, UJD SR, civil protection and state administration bodies.

EC members keep standby duties in weekly intervals. In case of event, EC members are activated on SS's instruction via the independent paging radio network and via the announcement server (automatic voice message, sms, e-mail) with return confirmation of received information.

After event announcement attending EC shift gathers in the ECC or back-up ECC in Trnava or Levice. Time limit from signal receipt for gathering of EC members on dedicated workplace is 30 minutes during working hours and 60 minutes during off-hours.

6.1.2 Possibility to use existing equipment

6.1.2.1 Provisions to use mobile devices (availability of such devices, time to bring them on site and put them in operation)

Various mobile devices are available on the NPP sites:

- Submersible pumps (administered by the fire brigade and operation support group)
- Portable generators (administered by the fire brigade)
- Mobile DGs (for SBO) – currently in procurement process
- Mobile fire pumps (administered by the fire brigade), additional ones in procurement process
- Mobile (portable) transformer 6kV / 0.4kV (administered by electric department.)
- Portable rectifier (administered by electric department).

These devices are administered by individual departments. The final stage of the on-going SAM implementation project – validation of SAMG procedures – will identify the need for and possibility to use such mobile devices and a programme will be introduced for their testing and maintaining in conditions corresponding with procedure validation.

6.1.2.2 Provisions for and management of supplies (fuel for diesel generators, water, etc.)

Working media inventory for DGs as the emergency power supply sources

There are two reactor units on each site and each unit has three independent emergency power supply sources – diesel generators (DG). One DG unit operation is required for heat removal.

Each DG as an independent emergency power source is equipped with its own 6m³ fuel tank and two external fuel tanks 100m³ each. This fuel inventory is sufficient for 240 hours i.e. 9-10 days for operation at its full power.

Inventory of other materials for accident management

Granulated boric acid inventory out of the technological circuits is 1,000 kg in each plant.

Anti dot (KI) inventory at designated places in EBO3,4 is approx. 8,000 packages, in EMO12 approx. 6,500 packages.

6.1.2.3 Management of radioactive releases, provisions to limit them

The principal design means for management and limitation of radioactive releases is preservation of containment functions. All mechanisms endangering the containment functions during severe accidents are addressed in specific guidelines of SAMG package. Use of newly installed systems and modifications for fulfilment of the above goals is as follows:

Integrity of containment boundary	Vacuum breaker Spraying from dedicated external emergency source of coolant Passive Autocatalytic Recombiners In-vessel retention Primary circuit depressurization
HPME	Primary circuit depressurization Mobile pumps via EFWS
Activity decreasing in the containment	Spraying from dedicated external emergency source of coolant
Long-term pressure management in the containment	Spraying from dedicated external emergency source of coolant Passive Autocatalytic Recombiners
Isolation of routes through the containment wall	Original design solutions, improved monitoring of radiation situation parameters

As described in details in chapter 6.2, SAM implementation project also includes installation of a set of design modifications or addition of new systems increasing reliability of SAMG strategies. General description is given in relevant sections of this chapter.

Limitation of radiation releases from NPP is supported by implementation of ESTE system enabling not only the prediction of source term for emergency planning purposes and its update based on monitoring of real on-site and off-site radiation data, but also prediction of radiation situation and optimization of long-term interventions.

Radiation monitoring system is divided into:

- Environment radiation monitoring
- Measuring of gamma radiation dose input in operational areas, reactor building, auxiliary building and NPP site,

- Measuring of volumetric activity of gases by continuous air sampling system from individual rooms,
- Measuring of aerosols volumetric activity in operational areas by continuous measuring using BDBA sensors and portable instruments for continuous aerosols measuring,
- Technological radiation monitoring

Radiation monitoring technological system (RMTS) is an autonomous unit. It works continuously and independently from other NPP systems; it contains 400 measuring channels. Besides RMTS, radiation situation is monitored also by independent stable radiation monitoring instruments. Sensors are installed in operational areas and important technologies and perform additional measurement not covered by RMTS. Signal-measuring units of independent instruments are located at the measuring place, in the radiation monitoring control room (RMCR) or in MCR.

6.1.2.4 Communication and information systems (internal and external)

In case of non-functional mobile and stationary telephone networks, walkie-talkies will be used for communication. The radio stations are situated namely in the departments for operation, dosimetry, electro, I&C, maintenance, physical protection and PFB. For communication with rescue staff, there are radio stations in ERO facilities, i.e. in ECC, in back-up emergency control centre in Trnava and Levice and in civil protection shelters. Totally about 300 walkie-talkies (400 in Mochovce) are used for communication. PFB is connected by a radio station and phone line equipped with local accumulator with the Regional Fire and Rescue Corps operational centre.

Technical hardware of the notification system intended for notification of operational staff and persons assigned to ERO are pagers ensuring one-way receipt of information.

There are about 400 pagers used in EBO3,4. There are also 308 pagers distributed to mayors of cities and villages in the EBO3,4 emergency zone for one-way informing. These receivers are intended for informing municipality and state administration representatives within the 21 km EBO3,4 zone. Pagers are part of EBO3,4 notification system. The notification paging radio network is in case of off-site power supply loss supplied by fixed UPS, accumulators enabling uninterrupted operation for 10 hours. Paging system transmitters and repeaters are not seismically reinforced.

EMO1,2 has 300 pagers available; another 203 pagers are distributed to mayors of cities and villages in the EMO emergency zone for one-way informing. These receivers are intended for informing municipality and state administration representatives within the 20 km EMO1,2 emergency zone. Pagers are part of EMO notification system. Paging, together with transmitting infrastructure, is system independent on public communication networks.

The second notification system hardware is the EBO3,4 ZUZANA phone notification system or the EMO notification server ensuring notification of persons assigned to ERO and representatives of self-administration and state administration in case of emergency to their mobile phones and fixed phones via voice messages, sms and e-mails. EBO3,4 ZUZANA system and EMO notification server ensures feedback for the sender about delivery of respective information. In case of overloaded public phone networks, delivery of sent information is not guaranteed. The equipment is not seismically reinforced.

Plant staff is notified of an extraordinary event by plant broadcast integrated into the internal warning system. If needed, sirens (internal plant warning system) can be used for informing the plant staff about an imminent danger.

Staff informing of the situation in EBO uses manual megaphones stored in shelters and collection points, in SE Protection & Security, Fire Protection and PFB vehicles. There are total 8 hand megaphones and 15 megaphones installed in vehicles at disposal in EBO3,4. Warning of employees and citizens within EMO emergency zone of occurrence of an extraordinary event uses the EMO warning system, which has about 186 end components – electronic sirens, with back-up power supply for minimally 72 hours. Sirens can broadcast the warning signal and citizens can be informed of an imminent danger also by the local control module through microphones.

ERO information system installed on the site and in the LRKO building in Trnava and Levice consists of the following components:

- Plant network with internet, electronic mail and dedicated electronic mail for crisis communication
- TSC technological information computer network
- Radiation monitoring central computer system with TDS
- PP information system for recording movement of persons and ERO members
- Software prognostic and classification tool (ESTE).

The information system provides real time data about condition of technological systems and radiation situation in the unit, on the site and its vicinity, current information about weather conditions, condition of persons. Terminal information systems are located in ERO centres, on ERO workplaces, back-up ECC and in SE, a.s. headquarters and in UJD SR. ERO information system devices have back up power supply.

6.1.3 Evaluation of factors that may impede accident management and respective contingencies

6.1.3.1 Extensive destruction of infrastructure or flooding around the installation that hinders access to the site

ERO members perform their activities in the emergency control centre located on the plant territory. Its construction is robust and meets gas-tight shelter requirements on CP facility.

The shelter is protected against penetration of radioactive substances in case of severe accident on plant territory and hermetically protected against dangerous substances, it is equipped with water system with separate service / potable water tanks, emergency illumination, decontamination part, dosimetry probe for dose rate and iodine volume concentration measurement, medical material, food, bottled water and PPE. Autonomous diesel generator power supply is installed there. Equipment of ERO centres creates conditions for long-term activity of EC. The workplace is usable also in case of extreme natural conditions provided that external roads are open to traffic or it can be accessed using alternative transport out of roads.

EBO 3,4

Transport in EBO3,4 vicinity is organized so that the main roads (highway D1, main railway route Bratislava – Zilina with Trnava and Leopoldov nodes) pass approx. 6km from the site. The main roads and railway routes in the region are free of hard transit sections in case of extreme natural conditions, but there is risk of extraordinary events in case of accidents of means transporting dangerous harmful substances. These sections can be bypassed considering the dense traffic network around the plant.

Considering large geodetic differences in altitudes, geographic relations and position of the waterworks Slnava with regard to EBO3,4 position, minimally one road will enable transport of staff and material to the plant even

in case of local flooding. This also applies to local floods due to extreme rains and down rush from adjacent rural areas to the power plant.

In case of larger damage of road surface and their flooding, on-duty members of EBO3,4 EC and intervention staff can be transported out of the roads using the transport means of the Ministry of Interior of the SR – CP based on a cooperation agreement. To ensure rescue, liquidation, and salvage works, 2 cranes and 2 platform cars can be used; today they are available in the maintenance department.

To ensure work of 12 EBO3,4 ERO members and to transport them to their workplace in case of an event in the plant there have been 4 passenger emergency vehicles assigned to transport also other on-duty members of EBO3,4 ERO. Procedures for transporting staff in case of abnormal and extreme situations are described in EWP.

EMO 1,2

The plant is located in the territory of the village Kalna and Hronom, close to former village Mochovce, approx. 12 km from the city Levice and approx. 14 km from Zlate Moravce and 11 km from Vrable. Kozmalovce waterworks and the river Hron are the nearest sources of water.

Considering large geodetic difference in altitudes, geographical conditions and the Kozmalovce waterworks position in consideration of the Mochovce NPP site, flooding evoked by the river Hron and the Velke Kozmalovce waterworks is not possible. Similarly, flooding of Mochovce NPP site due to damage of tanks 2 x 6,000 m³ of the raw water reservoir may be excluded with regard to the relief and position of this object.

Considering altitude and layout arrangement of the NPP site, there is no risk of the site flooding due to inflow of rainfalls from adjacent power plant rural areas.

Access roads to the site can be endangered by the river Hron. Potentially endangered access roads to the site are from Levice and Tlmace directions. In case of larger damage of road surface and their flooding, on-duty members of EMO1,2 EC and intervention staff can be transported out of the roads using the transport means of the army units in Levice based on a cooperation agreement with the army. To ensure rescue, liquidation, and salvage works, 2 cranes and 2 platform cars can be used; today they are in the maintenance department.

To ensure work of 16 EMO1,2 ERO members and to transport them to their workplace in case of an accident, there have been 4 passenger emergency vehicles assigned to transport also other on-duty members of EMO1,2 ERO. Procedures for transporting staff in case of sub-standard and calamity situations are described in the procedure HO/8707 “Gathering of staff at abnormal and extreme situations”.

6.1.3.2 Loss of communication facilities / systems

Communication means in ERO – stationary network and radio network

Communication equipment of stationary plant network is powered from redundant sources and, in case of grid supply loss – backed up by accumulators for 10 hours. Independent communication equipment for direct stationary connection between the MCR and dedicated points in unit technology are backed up by accumulators for 10 hours in case of power supply loss from the grid. All shift staff, i.e. unit control rooms and intervention shift staff are equipped with walkie-talkies enabling communication for 10 hours without recharging.

In case of non-functional mobile and stationary telephone networks, walkie-talkies will be used for communication.

The walkie-talkies (radio stations) are available in EBO3,4 ERO facilities, i.e. EBO3,4 ECC, back-up ECC Trnava, in CP shelters and on CP assembly points and in PFB. It is necessary to ensure battery charging after elapsing the

mentioned time. Totally about 300 walkie-talkies are used for communication in EBO3,4. For communication with rescue staff, there are radio stations in EBO3,4 ECC, in Trnava back-up emergency control centre and in civil protection shelters. Totally about 300 walkie-talkies are used for communication in EBO3,4. EBO PFB is connected with the Regional Fire and Rescue Corps operational centre via a radio station with own power source and phone line with local accumulator. Besides EMO1,2, walkie-talkies are also in EMO12 ERO facilities, i.e. EMO1,2 ECC, back-up ECC Levice, in CP shelters and CP assembly points and in PFB. Totally about 400 walkie-talkies are used for communication in EMO1,2. EMO PFB is connected by a radio station with local accumulator with the Regional Fire and Rescue Corps operational centre.

Announcement and information system

Technical hardware of the notification system intended for notification of operation staff and persons belonging to the ERO are pagers ensuring one-way receipt of information; similar notification is used for villages and state administration representatives within 20km from the emergency zone. The notification paging radio network is supplied by fixed back-up power supply sources (accumulators) in case of grid supply loss enabling uninterrupted operation for 10 hours. Paging, together with transmitting infrastructure, is system independent on public communication networks.

6.1.3.3 Impairment of work performance due to high local dose rates, radioactive contamination and destruction of some facilities on site

SAMG consider unavailability of certain equipment or its failure due to the severe accident. Therefore, strategies are developed with alternative actions. Equipment installed or credited within the SAM project is designed so as to keep their operability under severe accident conditions with high confidence.

Extreme situations related to failure or damage of also newly installed systems are covered in the SAM project by installation of three pipelines with nozzles installed on the exterior surface of reactor building and auxiliary building providing for possibility of coolant make-up from external mobile sources: a) to the reactor cavity to keep heat removal from RPV and prevention of ex-vessel corium impact; b) to the SFP from the top, independently from the pool cooling system; and c) to make-up of coolant emergency source tanks (that can be also used for coolant make-up to the reactor and containment spray system for long-term heat removal from the containment).

Local radiation conditions in technological structures can affect performance of activities required for recovery of equipment needed for long-term SAM (e.g. heat removal from the containment). Currently, no adequate information is available for complete solution of this issue. The issue will be addressed in the final stage of the SAM implementation project.

6.1.3.4 Impact on the accessibility and habitability of the main and secondary control rooms, measures to be taken to avoid or manage this situation

Habitability of the main control room and emergency control room (in smaller scope) was reinforced in the project by installation of the following design modifications:

- Innovation of the MCR HVAC system and provision of its recirculation regime (formation of over-pressure in the control room for minimization of penetration of external radioactivity)
- Addition of iodine filters
- Sealing of the complete MCR area and walling of windows
- Sealing of cable areas under MCR and ECR against smoke leakages.

High radiation load could endanger habitability of MCR, namely during hypothetical severe accidents with an open reactor. Therefore, a possibility was arranged to control selected newly installed SAM equipment required in long-term horizon, as part of reconstruction of ERO emergency and support centres with radiation protection (shelter type). Required I&C system and power supply of these consumers form a part of the SAM implementation project.

6.1.3.5 Impact on the different premises used by the crisis teams or for which access would be necessary for management of the accident

Newly constructed spaces for the crisis team (ECC) is in an underground shelter resistant against all foreseeable severe accident impacts occurring at open reactor regimes; a relevant source term was used for the design shelter dimensioning. The shelter is equipped with technical air source for internal circuit and filters for CO₂ removal and oxygen supply, thus ensuring possibility of autonomous existence during critical phases of severe accident (at leaks of inert gases). Shelter dimensioning is sufficient for two ERO shifts and MCR staff from both nuclear units.

In case of large accident, ERO members gather in back-up ECC located at the boundary of the emergency zone.

6.1.3.6 Feasibility and effectiveness of accident management measures under the conditions of external hazards (earthquakes, floods)

Majority of activities needed for severe accident management are controlled from the MCR or ECC that are not directly threatened by effects of extreme external events. Equipment installed as part of the SAM project is located in buildings resistant against external effects (seismicity to SSE level); thus, their usability and availability will not be largely affected by the external event. This means that management of severe accidents caused by extreme external events is identical with the case of internal initiating events.

Internal floods caused by external flooding are solved by already adopted measures and it can be assumed that escalation of an event into a severe accident is prevented.

6.1.3.7 Unavailability of power supply

Unavailability of power supply sources during severe accident is one of assumptions of SAM implementation project and is solved preventively by increased redundancy of sources with robust design (also against extreme weather conditions). All consumers installed within the SAM project are – besides standard power supply from existing systems – also supplied from the dedicated SAM DG independent from existing safety systems, thus serving as redundant power source. Home consumption supplies including connection of new SAM DG and additional mobile power supply sources 0.4kV for SBO are described in chapter 1 of this report.

6.1.3.8 Potential failure of instrumentation

Assumption of potential unavailability of certain measuring devices is one of the SAM project bases. SAMG strategies are designed so that to enable their execution and monitor their efficiency based on diverse measurements to decrease their vulnerability in case of failure of some measurements.

I&C design principles and requirements for newly installed systems were defined at initiation of the SAM project. Even though qualification of instruments for severe accident conditions is not required, it is necessary to prove its survivability in such conditions. Analyses were prepared for determination of thermal-hydraulic and radiation parameters in areas where new I&C is to be installed serving as basis for definition of requirements on installed I&C equipment.

The potential for availability of the instrumentation needed for execution of SAMGs is significantly increased by implementation of a new SAM DG as the ultimate power supply for all I&C installed in the frame of the SAM project, specifically I&C related to major modifications.

6.1.3.9 Potential effects from the other neighbouring installations at site, including considerations of restricted availability of trained staff to deal with multi-unit extended accidents

SAM implementation project is based on the assumption of severe accident occurrence on only one of nuclear units, in line with the existing rules. Certain design solutions (e.g. SAM DG) are assumed to cover both units, so that it is not possible to exclude interferences between the units and resulting effects on SAM. Similar mutual interdependencies are also in the technological part and due to potential influence of a severe accident in one unit on other unit due to relatively close location of the MCR and ECR, common turbine hall and common reactor hall shared by both units. Such interrelations between the units should be considered in future stages of the SAM project.

6.1.4 Conclusion on the adequacy of organizational issues for accident management

The organizational aspects of accident management of DBA, BDBA and severe accidents as reflected by the respective procedural guidance complies with all applicable recommendations and requirements for accident management in NPPs, follows best practice in the industry and, therefore, the organization issues are considered as adequately covered. However, it should be noted that the structure and scope of the emergency response teams, especially SAMG team is currently defined from the perspective of a severe accident in one unit only, in line with the SAM project principles.

6.1.5 Measures which can be envisaged to enhance accident management capabilities

At present, implementation of comprehensive SAM is on-going in accordance with the programme established in 2009. No additional measures beyond this project are currently envisaged. It should be however taken into account that in accordance with the currently valid requirements the measures have been developed considering occurrence of a severe accident only on one of two units; this assumption should be reconsidered.

SAM project is being currently implemented in both EBO 3,4 and EMO1,2 based on originally defined scope with assumptions for severe accident management on one of two units. The project completion will be followed by evaluation of possible extension to management of a severe accident on both units. Further SAMG improvement and preparation of additional supporting documents for decision making by SAMG and MCR teams will be adopted based on SAMG validation results at project completion.

6.2 Accident management measures in place at the various stages of a scenario of loss of the core cooling function

6.2.1 Before occurrence of fuel damage in the reactor pressure vessel/a number of pressure tubes (including last resorts to prevent fuel damage)

The accident management measures belonging to the preventive phase of AM are systematically built into the plant specific symptom oriented EOPs which follow the Westinghouse approach. The EBO and EMO EOPs cover all operational regimes of the plants, i.e. full power or shut-down regimes. EOPs package of both EBO and EMO

NPPs has been adequately validated and there is a continuous cooperation with Westinghouse providing for maintenance and upgrading of EOPs in the frame of the world-wide cooperation between WOG NPPs.

6.2.2 After occurrence of fuel damage in the reactor pressure vessel/a number of pressure tubes

After identification of fuel damage based on measurable symptoms the AM enters the mitigative phase. The transition between the preventive and mitigative phases is described and justified in the SAMG documentation and a specific procedure/guideline SA CRG-1 has been developed to provide guidance for control room staff until the control of the severe accident is transferred to the SAMG team. The SAMG team is a part of experts convened to the ECC. The SAMG team should take over the responsibility within 1 hour of the severe accident course. All AM measures aimed at protecting the containment and preventing/ mitigating the consequences of severe accident on environment and public are built into the SAMG package. SAMG cover all operational regimes of the plant consistently with the respective EOP.

In addition to the generally adopted approach to build the response to severe accident mainly by usage of all available equipment, safety as well as non-safety, a set of dedicated hardware modifications and installation of new hardware extends the scope of potentially applicable measures and significantly increases the probability of the success of the strategies in SAGs and SCGs guidelines.

6.2.3 After failure of the reactor pressure vessel/a number of pressure tubes

The prevention of reactor pressure vessel failure by installation of in-vessel-retention hardware modification and development of respective guideline SAG-3 of SAMG package is considered adequately reliable. The failure of vessel can be therefore considered as negligible residual risk.

Should the reactor vessel fail the major relevant failure mode of the containment is the failure of entry door into the reactor cavity due to thermal attack and long term over pressurisation of the containment due to molten core concrete interaction. SAMG provide guidance to partially limit the consequences of long term over pressurisation by usage of containment spray system as well as usage of external injection system installed in the frame of SAM project.

SAM implementation project does not include any modifications directly dedicated to limitation of impact of reactor pressure vessel failure.

6.3 Maintaining the containment integrity after occurrence of significant fuel damage (up to core meltdown) in the reactor core

6.3.1 Elimination of fuel damage / meltdown in high pressure

6.3.1.1 Design provisions

Original design

Severe core damage can occur in several scenarios at escalation of BDBA. Among them there are scenarios caused by loss of heat removal from the primary to the secondary circuit, when the RCS integrity is maintained and the core degradation followed by corium relocation takes place at high pressure. In this case, the reactor pressure vessel is loaded with high pressure and high temperature, its own weight and weight of corium. The top priority is to decrease pressure in the primary circuit and prevent RPV melt through at high pressure

resulting in high pressure melt ejection (HPME), as it could result in damaging the reactor cavity door, transport of melted fragments to the containment, thermal endangering of its walls and fast containment heating. Another benefit of reduced pressure is lowered probability of SG tube failures and possibility to make-up coolant from low-pressure sources.

In the original design the RPV failure at high pressure could be prevented by two sets of the main safety valves and one relief valve of the PRZ. PRZ safety valve part power supply is provided from the vital power supply. All valves are controlled remotely manually from MCR. PRZ SV system equipment has seismic classification.

Installed modification

Considering the high priority of RCS de-pressurization, the SAM implementation project includes installation of redundant independent system qualified for severe accident conditions. Redundant de-pressurization line is to be used before the accident escalation to a severe accident, so that probability of failure to open due to previous thermal stressing or by other mechanism is minimal. Installed system forms part of RCS pressure equipment. Part non-separable from the RCS including the isolation valves is seismically resistant. The system is classified to safety class 1.

The system is supplied from SAM DG dedicated for power supply of equipment required for SAM. System operation during design basis accidents is not required. The depressurization system is qualified, highly reliable back-up with full capacity usable at failure of standard lines for RCS depressurization (PRZ RV, PRZ SV).

The depressurization of the primary system is the highest priority activity in the preventive as well as mitigative AM. The respective proceduralised actions are consequently built into the symptom based critical safety function restoration guidelines from the EOPs package (procedures FR-C.1 and FR-C.2), secondly the depressurization action (if needed) is one of the transfer steps between EOPs and SAMG. In addition the SAMG package itself contains a specific guideline SAG-1 dedicated to response to the primary system pressure exceeding 2.5 MPa.

6.3.1.2 Operational provisions

RCS depressurization procedures are included in EOP procedures FR-C.1 and FR-C.2 and the guidelines SA CRG-1 and SAG-1 of the SAMG package providing for high reliability of required functions. Installation of additional qualified depressurization line and strategies in SAMGs provide for high reliability of RPV failure prevention at high pressure.

6.3.2 Management of hydrogen risks inside the containment

6.3.2.1 Design provisions, including consideration of adequacy in view of hydrogen production rate and amount

Original design state

During a severe accident large amount of hydrogen produced due to exothermic reaction between zirconium and steel and water vapour. In case of further accident escalation with failure of the reactor pressure vessel, additional significant amount of flammable gases (hydrogen and CO) would be produced due to corium interaction with reactor cavity concrete. Total production of flammable gases during this ex-vessel phase exceeds several times their production during the in-vessel phase, even though its rate is lower than during the in-vessel phase.

Zirconium weight in the reactor is approx. 18,000 kg. According to the calculation the amount of hydrogen generated during the in-vessel phase ranges from approx. 300kg (LB LOCA) to 500kg (SBO) depending on the scenario. Heat production from the exothermic reaction is approx. 6,400kJ / kg of reacted zirconium, i.e. generated heat significantly contributes to the requirements for heat removal from the containment. Original V213 design does not provide means for reliable hydrogen removal at severe accidents. Theoretical possibility to ensure controlled early hydrogen ignition by discharges in installed electric consumers in the containment is unreliable and unavailable for certain scenarios (SBO).

The hydrogen production rate during severe accident depends on many factors. From the sensitivity studies in the past follows that the peak hydrogen production rate in the early phase of a severe accident can be more than 1 kg per second.

Hydrogen generated during severe accidents is the most critical and earliest risk for V213 containment integrity. With regard to ensuring containment integrity the most significant is rate and amount of hydrogen released from the primary circuit to the containment and resulting time course of hydrogen concentration in the containment, which in turn depends on steam concentration, and total amount of generated hydrogen.

Installed modifications

One of the presumptions of managing the hydrogen issues during severe accidents is reliable prevention of the transition to the ex-vessel phase. This issue is covered by installation of a group of modifications enabling retention of the molten corium inside the RPV and its reliable external cooling.

Technical solution of the hydrogen issues consists of installation of 28 passive auto-catalytic recombiners RF1-1500T and 4 passive auto-catalytic recombiners FR1-750T of the company AREVA. Installation of recombiners in the containment is a standard solution; recombiners have been installed in more than 100 NPPs in various countries. Recombining ability of the recombiners was proved also by experiments on experimental stand PHEBUS and at large-scale tests on THAI facility.

Threshold hydrogen concentration for recombination commencement is ~ 2% vol. at atmosphere temperature of 50°C. At reference parameters provided by the manufacturer, recombiners are capable to ensure total hydrogen recombination rate of approx. 160kg/hour. Selection of capacity and location of installed PAR is based on results of studies of hydrogen distribution performed by various organizations. Generally, the total capacity of recombiners provides for recombination of hydrogen in all analysed sequences below 4-5 % in less than 1 hour. For the scenarios with maximum rate of hydrogen release into the containment (e.g. LOCAs) the period when the steam inertization of containment is credited is less than 30 min.

PARs are designed so as to resist expected emergency temperatures and are seismically resistant. Possible failure (e.g. mechanical damage) of a single PAR has no effect on operability of other PARs in the system. Considering their installation in various containment areas, failure of several PARs is unlikely. The overall system capacity is designed with sufficient margin; thus, failure of several components does not cause failure of the system as a whole.

6.3.2.2 Operational provisions

SAMG considers hydrogen management in strategies defined in several SAG and SCG guidelines. Hydrogen management procedure in the first SAMG revision was based on controlled hydrogen combustion at sufficiently low concentration using electrically supplied igniters. Implementation of PAR based solution with significantly lower demands for staff actions requires updating of the hydrogen management strategy in SAMG.

6.3.3 Prevention of overpressure of the containment

6.3.3.1 Design provisions, including means to restrict radioactive releases if prevention of overpressure requires steam / gas relief from containment

Original design state

Radiation leaks are minimized by keeping the containment pressure boundary integrity dimensioned both to internal over- and under-pressure. Besides the civil part, containment pressure boundary also includes equipment providing for isolation under accident conditions or ensuring its hermetic status.

The containment is dimensioned for the design-basis accidents in the following ranges:

Maximum design pressure:	245 kPa
Minimum design pressure:	80 kPa
Maximum temperature:	129°C
Integral ionizing radiation dose:	10 ⁵ Gy in 10 years

Containment pressure boundary tightness for EBO3,4 (constantly being improved):

- Initial design leakage rate < 13% vol. / 24 hours at 150 kPa over-pressure
- Actual value is approx. 5% vol. / 24 hours.

Containment pressure boundary tightness for EMO1,2 (constantly being improved):

- Initial design leakage rate < 5% vol. / 24 hours at 150 kPa over-pressure
- Actual value is approx. 2% vol. / 24 hours.

The containment is integrated with the reactor building into a common structure. Internal hermetic compartments include SG room, bubbler condenser tower with four air traps, HVAC centre and refuelling pool. In order to maintain integrity and tightness of the pressure boundary, it is necessary to prevent excessive over- and under-pressure in the containment.

Prevention of excessive over-pressure in the containment

Management of pressure in the containment is ensured by two systems:

- **Passive pressure suppression system** – its aim is to limit over-pressure at relevant initiating events (e.g. LOCA, steam line rupture). This fully passive function is provided by bubbler condenser trays used for condensing of expanding coolant. Current V213 design does not include a system for controlled filtered venting as a mean for prevention against long-term over-pressurization following loss of the containment heat removal. At the same time the system also provide for capturing fission products in the water pools of the condenser.
- **Containment spray system** – its aim is to decrease pressure and to remove heat from the containment to ESCW via the spray system cooler in long-term recirculation operational regime. Operation of minimally one spray system train can assure permanent containment heat removal even after a severe accident. Based on existing analyses it can be extrapolated that the containment withstands complete loss of heat removal for 3-5 days until reaching the limiting pressure defined for SAM project (350 kPa abs).

Prevention of excessive under-pressure in the containment – installed modification

SAM project includes installation of a system enabling prevention of excessive under-pressure, by controlled return of part of non-condensable gases from the air traps back to the containment (to the space in front of condensing trays) and prevention of deep under-pressure. This is done by installation of four electric operated valves and two check valves with interconnecting and exhaust piping. The system is controlled manually by the operator. Advantage of the adopted solution is prevention of interruption of integrity of external part of the containment as only internal compartments are mutually interconnected.

6.3.3.2 Operational and organizational provisions

Prevention of containment damage due to excessive static over-pressure, dynamic over-pressure resulting from hydrogen combustion and impermissible under-pressure is ensured by strategies described in several guidelines of SAMG package. Strategies use original design containment equipment, but their feasibility is significantly supported by new systems installed as part of the SAM project.

6.3.4 Prevention of re-criticality

6.3.4.1 Design provisions

Prevention of criticality is ensured by injecting into the primary system or containment only coolant with boric acid concentration exceeding 12g/kg. SAMG explicitly prohibits make-up of unborated coolant during SAM, which is one of differences from generic WOG SAMGs. To increase the coolant source redundancies, an external coolant tank is installed as part of SAM implementation enabling coolant make-up to:

- The primary circuit / reactor
- Spray collector
- Spent fuel pool.

Besides provision of the safety function – criticality control, the external source also provides for the function of heat removal from the reactor and SFP and from the containment atmosphere by spraying. Containment spraying from external source increases reliability of pressure control in the containment and decreases releases of radioactive substances by reducing the pressure and in particular by washing-out fission products from the containment atmosphere.

External coolant source in EBO3,4 consists of three tanks containing boric acid solution 12g/kg, with total usable volume 1,250 m³ and two pumps with pressure heads 0.85 MPa (LP) and 2.5 MPa (HP). The system is located mostly in the auxiliary building. Location of tanks in EMO1,2 has not been fixed yet, but the design similar to EBO3,4 is preferred in order to provide for maximal use of experiences. Functioning of the system and applicable requirements will be identical.

6.3.4.2 Operational provisions

The injection into the primary system and prevention of further degradation of the reactor core during severe accident is the main goal of the guideline SAG-2. The guideline provides all necessary instructions on usage of existing plant systems and new installed external SAM source of water allowing injection of borated coolant directly into the primary system. The explicit prohibition of usage of unborated water is stated in the SAG-2. The operational provisions to prevent recriticality can be considered adequate.

6.3.5 Prevention of basemat melt through

6.3.5.1 Potential design arrangements for retention of the corium in the pressure vessel

Original design condition

According to the original V213 design, the long-term core cooling phase during LOCA is based on coolant recirculation from the SG box via the spray system heat exchanger after exhausting all coolant from the emergency system tanks (in about 30 minutes for some kinds of events). Coolant released from the broken reactor coolant system is collected on the floor of the SG box and is available for recirculation core cooling mode.

Rupture of the reactor pressure vessel is considered unrealistic due to strong conservatism of the vessel design and strict inspections, so that reactor cavity is not included in the recirculation loop – V213 design does not enable controlled coolant flow to the cavity or coolant return from the cavity to SG box. Thus, original V213 design did not enable external RPV cooling or controlled corium cooling on the cavity bottom during the ex-vessel phase in case of RPV failure.

Analyses within the project PHARE 4.2.7a showed that the reactor cavity is endangered shortly after transition to the ex-vessel phase of the accident. Limiting structure is the cavity access door assumed to fail either due to corium thermal attack or due to sudden pressure increase resulting from HPME. There is also risk of radioactive coolant leak via non-isolable drainage piping and via induced leaks through the sealed penetrations in the cavity wall.

Implementation of external RPV cooling requires the following in order to prevent the basemat failure: a) early reactor depressurization; b) early flooding of the reactor cavity; c) ensuring contact between RPV wall and coolant before corium relocation to the reactor bottom; and d) sufficient venting of steam generated in the reactor cavity back to SG box. Design solution is identical for existing as well as for new units.

Modifications required for flooding of the reactor cavity and provision of external RPV cooling:

- Modification of the drainage system of bubbler condenser trays - SAM project provides for the reliable power supply of the bubbler condenser system valves from SAM DG, thus providing coolant availability from the bubbler condenser trays also under severe accident conditions initiated by SBO.
- Filtrating sieve structures – coolant inlet line to the reactor cavity and towards the external RPV surface is equipped with two-stage filtration of impurities as prevention of clogging of the narrowest sections of the cooling pathway around the reactor vessel.
- Installation of passive opening mechanism in RPV thermal insulation – installation of circular intake opening with removable cover controlled by special float opening device installed on the bottom of the RPV thermal shield in the reactor cavity.
- Installation of a door in the reactor thermal insulation at the level of reactor nozzles in order to reduce hydraulic resistance for steam outflow from the cavity.
- Coolant make-up line to the reactor cavity from the external mobile source – installation of a line (dry channel) mouthed on external reactor building wall enabling coolant supply to the reactor cavity from a mobile external source. The line allows for the use of the back-up coolant source for external RPV cooling without necessity of coolant on SG box floor.

Modifications required for isolation of the reactor cavity and prevention of non-returnable coolant leak:

- Isolation “siphon” on two horizontal air ducts with flooding structures– modification of both HVAC ducts of the reactor cavity cooling system. Flooding structures will be installed on the siphon down coming pipe

enabling the cavity flooding at severe accidents (see the Figure 24). They are installed on both sides in interconnecting corridor between SG box and bubbler condenser tower and protected against undesirable accident consequences (flying objects, hitting by coolant flow, insulation fragments). Flooding valves are controlled actively from MCR. They are assumed to be opened by the operator at transition between the EOP and SAMG.

- Improving of hermetic door sealing – provision of sufficient resistance of reactor cavity hermetic door seal to long-term load caused by increased radiation, heat and pressure for longer time (including contribution from hydrostatic pressure in flooded reactor cavity).
- Isolation of special sewage inlet from the reactor cavity floor - installation of closing plug on the special sewage collector in the reactor cavity.

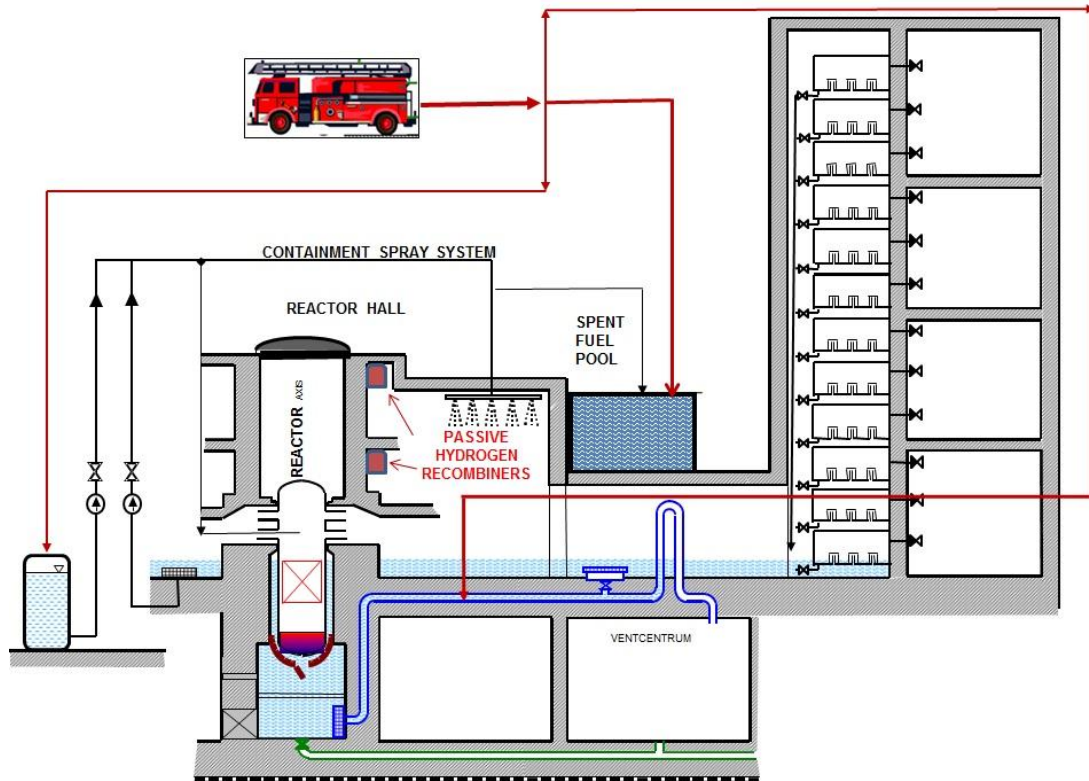

Figure 24: Overall arrangement for reactor cavity flooding and containment spraying

6.3.5.2 Potential arrangements to cool the corium inside the containment after reactor pressure vessel rupture

Considering limited strength of the reactor cavity in case of RPV failure, regardless of coolant presence in the cavity, it is unlikely to prevent failure of doors. The failed door enable leak of radioactive medium, and possibly also corium, to the areas out of the containment and serious worsening of the accident progression.

Therefore, no special additional measures were assumed for hypothetical corium cooling on the cavity bottom. Existing measures included in the external RPV cooling strategy implementation, namely the coolant feeding from SG room to the reactor cavity by gravity and steam removal from the cavity back to SG room present the maximal achievable protection of the cavity bottom following RPV failure. Stabilization of the melt composition, termination of concrete degradation and long-term preservation of the cavity integrity cannot be guaranteed by the above mentioned heat removal method. This significantly increases the importance of RPV failure prevention. On the other hand it can be stated that the implemented modification provides for stabilization of molten corium with adequately high confidence.

6.3.5.3 Cliff edge effects related to time delay between reactor shutdown and core meltdown

Operator's failure to perform actions in line with the developed strategies, failure of equipment or unexpected development of the accident differently from considerations in the strategies (or equipment design) could hypothetically result in the failure of the containment integrity during the severe accident. To eliminate possibility of such scenarios the following principles and rules are observed in the SAM project and in SAMG:

- Preference is given to dedicated passive equipment or equipment not used prior the severe accident phase of the event, and mostly supplied from the dedicated electric power source;
- All actions important for maintaining containment integrity are in addition to the provisions of the original VVER 440 design supported by additional new design features (highly reliable modifications).

Majority of early (short term) personnel actions included in SAM are included in the procedure SA CRG-1 that is the only one performed by staff from MCR before ECC activation. Actions in SA CRG-1 are prepared as algorithm in form of clear instructions and are included in the basic MCR staff training. Therefore the required actions should be performed very reliably.

Staff actions and effective use of available systems enable RPV integrity control as well as pressure and temperature control in the containment for several days. During this period, regular spraying of containment helps to maintain minimum internal over-pressure, together with fission products washing out the main means for mitigation radiological consequences. Considering the passive design solution adopted for hydrogen management only monitoring of its successfulness is needed.

In case of unavailability of the containment spray system, recovery of minimally one containment spray system train for long-term containment heat removal has to be provided within approx. 5 days, during which the residual power and heat from chemical reactions can be accumulated in the containment structures and walls. In addition a study has been developed on possible containment heat removal by operation of the containment ventilation systems.

6.3.6 Need for and supply of electrical AC and DC power and compressed air to equipment used for protecting containment integrity

6.3.6.1 Design provisions

Original design state

Current power supply sources are designed for reliable control of design-basis accidents; back-up is mostly optimized for managing SBO events caused by failures of electric equipment. Home consumption power supply has been described in chapter 1.3.

Installed modification

In order to increase reliability of SAM, the SAM project contains a partial project "Emergency power supply source" focusing specifically on power supply during severe accidents. Installed SAM DG is independent from the existing normal operation systems, abnormal operation systems and safety systems for management of DBA. The emergency source is planned as common for two units.

In EBO 3,4 SAM DG has container design; the container contains one diesel generator with electric power up to 1,200 kW and accessories (transformer, catching basin under DG, fuel tank with 3,000 l volume, air intake opening, exhaust). SAM DG home consumption will be supplied from independent external substation 0.4kV for power supply of DG electric heaters, fuel pump and outlet for cooling water supply in case of severe accident.

The layout arrangement of SAM DG and relevant 6kV substation OBG was selected with regard to the need for SAM DG connection to close cable channels connecting also the 3rd grid source – Madunice hydro power plant. SAM DG electric power is supplied to new external 6kV substation OBG. The substation OBG is equipped with transformer 6 / 0.4kV (1,000kVA) for supplying consumers in case of severe accident, and also with outlet for emergency ECC object supply during severe accident.

SAM DG boundary consists of the SAM panels installed in unit MCR and identical panels on the back-up workplace in ECC object. Use of SAM DG at power loss supply depends on decision of SAMG specialists from TSC. SAM DG can be used in appropriate scope (i.e. without endangering its full operability for management of potentially severe accident) already for prevention of the core damage, e.g. under SBO conditions. From this point, it represents another power supply redundancy for managing SBO events.

In EMO1,2 the emergency power supply is in the design preparatory phase. The solution will take into consideration plant specific electric connection to the grid and concept home supply of four EMO1,2,3,4 units. Therefore, the detailed solution will differ from the solution developed for EBO3,4. Nevertheless, the solution will be functionally similar to EBO3,4 design; SAM panels will be installed in EMO1,2 unit MCR and identical panels will be installed on the back-up workplace installed in the ECC building.

6.3.6.2 Operational provisions

Recovery of failed essential power supply, extension of life of existing DC resources (batteries) and initiation and control of SAM DG is included in the normal operating procedures, EOPs and SAMGs and TSC documentation. The feasibility of required local interventions is a part of SAMG verification and validation.

6.3.7 Measuring and control instrumentation needed for protecting containment integrity

Original design

Consumers and measurements installed as part of the SAM project were not included in the basic design.

Modification in progress:

SAM project contains also a partial project “SAM information system and control SAM elements and components” containing implementation of reliable I&C system for newly installed systems and information system in the scope needed for implementation of strategies foreseen in SAMG.

The information system for SAM support relates with PAMS - Post-accident monitoring systems in line with recommendations of US NRC RG 1.97.

From technical point of view it includes implementation of a set of measuring sensors, relevant cabling and evaluation devices installed mostly inside existing objects in the RB, auxiliary building and ECC.

Proposal of the design considered requirements on scope of information needed for implementation and monitoring of successfulness of strategies in SAMG. Systematic evaluation covered all SAMG strategies, diagnostic diagrams, set points in strategies from view point of availability of reliable data and redundancy of their provision in the information system accessible to teams deciding of SAMG use, SAMG team in the emergency commission and MCR team.

EBO3,4 design also included analytical determination of qualification requirements on newly installed I&C and measuring equipment. Environmental qualification requirements were set based on existing severe accident

analyses and new prepared radiation situation analyses in selected RB areas. Analogical requirements will be applied to project implemented in EMO1,2.

6.3.8 Capability for severe accident management in case of simultaneous core melt/fuel damage accidents at different units on the same site

The accident management concept is currently based on assumption of severe accident evolving only in one unit, in line with existing legislation and recommendations. The capability to respond to severe accident in two units simultaneously is, however, affected only in few areas and only in quantitative aspects. Detailed analysis of increased need for additional personnel and increased needs for make-up depleted external water sources are analysed in the plant specific stress tests technical reports. Installed modifications (pumps, pipelines, valves) provide sufficiently for capacities to manage the situation.

6.3.9 Conclusion on the adequacy of severe accident management systems for protection of containment integrity

The SAM project involves installation of several groups of major plant modifications which as a whole provide for better prevention of escalation of severe accidents, enhance the capability of NPP personnel to mitigate the consequences of severe accident and increase the probability of maintaining the integrity of the containment. The scope of the on-going project has been defined based on detailed vulnerability study of V213 behaviour and identification of challenges during severe accidents. The approved scope of the SAM project is considered as adequate.

6.3.10 Measures which can be envisaged to enhance capability to maintain containment integrity after occurrence of severe fuel damage

Other possible measures extending the current scope of the SAM project will be analysed after the project completion, based on results of SAMG validation and analytical justification of strategies for management of representative severe accident scenarios.

6.4 Accident management measures to restrict the radioactive releases

6.4.1 Radioactive releases after loss of containment integrity

6.4.1.1 Design provisions

An airtight zone is arranged in compartments around the containment inside the reactor building with ventilation systems equipped with filters capturing the fission products escaping through possible containment leakages. This zone performs the function of the secondary containment. Implementation of SAM project also includes connection of the fans of the vent system to dedicated power source to ensure their operation also during severe accidents caused by the loss of power supply. This measure significantly contributes to mitigation of radiological consequences in the plant vicinity.

Part of the primary containment pressure boundary is not provided with the secondary containment and pertinent leakages from this part would result in direct activity release to the environment.

As the leak size is roughly proportional to internal containment pressure, all modifications installed within SAM project aimed in improvement of containment spray system reliability and containment heat removal from the

containment or keeping the lowest possible over-pressure in the containment contribute to lowering radiation leaks to the environment. These are:

- Improvement of the spraying system reliability, removal one of two FCVs at the containment inlet, reinforcement of the spray pump against radiation and measures aimed at system recovery in the case of failure;
- Installation of emergency external water source with tank volume 1,250m³, pump supplied from SAM DG enabling containment spraying. Tanks will be continuously filled by a route (dry channel) from mobile water source. In order to ensure reliable access to the route during emergency conditions, it is mouthed on the outer sheathing of the auxiliary building.

Operability of the containment sprays will reduce radioactive releases even in the case of loss of containment integrity.

6.4.1.2 Operational provisions

The mitigation of the loss of containment integrity and consequent releases of radioactive releases is described in SAMG severe challenge guideline SCG-1. All relevant operational provisions are included in the guideline in sufficient detail.

The minimisation of impact of radioactive releases on plant personnel and public is the main concern of emergency planning and response. Detailed procedures are available for all activities of emergency response organisation and their adequacy and compliance with legislation has been verified during the Periodic Safety Review in 2008 and 2009.

6.4.2 Accident management after uncovering of the top of fuel in the fuel pool

6.4.2.1 Hydrogen management

Assessment of possible hydrogen concentration in the reactor hall formed due to fuel degradation in the spent fuel pool was performed as part of the hydrogen management. It was concluded that there is no need to install PARs in the reactor hall, since the resulting hydrogen concentration, considering the reactor hall volume of 160,000 m³, is below the PARs operational limit. However, this assessment did not consider possible imbalance in hydrogen distribution and possibility of higher concentration above the pool. Such detailed analyses are not available yet.

Currently, safety of the spent fuel pool is solved by reliable prevention of severe accident occurrence that could cause dangerous hydrogen concentration in the reactor hall. The SAM project includes installation of two mutually independent routes enabling make-up of borated coolant into the pool. The first one is a route from the external emergency coolant source supplied to the spent fuel cooling piping. The other route is the connection to the external reactor building wall and leads to the storage pool from the top, i.e. without relation to the pool cooling piping. Both newly installed routes (in addition to previously existing ones) are dimensioned so as to provide for fast recovery of level in the pool in case when its integrity is preserved.

6.4.2.2 Providing adequate shielding against radiation

V213 original design considered isolation and covering of the spent fuel pool by providing sufficient protective coolant layer above the fuel. Thus, the protection against radiation is provided by sufficient capacities of systems recovering the coolant inventory in the pool. This is addressed in SAM projects by installation of two independent pipelines for water injection.

6.4.2.3 Restricting releases after severe damage of spent fuel in the fuel storage pools

Ventilation system exhausting the air from above the storage pool is not equipped with iodine filters and so it cannot be used for the radiation situation management above the pool. Therefore, also limitation of radioactive leaks after fuel degradation (severe accident in SFP) can only consist of recovery of sufficient level above the fuel to provide for efficient washing of fission products from steam leaking to the reactor hall.

6.4.2.4 Instrumentation needed to monitor the spent fuel state and to manage the accident

The storage pool is equipped only with instrumentation needed for supporting normal operation: level measurement and coolant temperature measurement. Two new dosimetry measurements will be installed in the reactor hall as part of the SAM project (1 measurement / unit) supplying signals to PAMS that could be indirectly used for monitoring of the spent fuel pool conditions.

6.4.2.5 Availability and habitability of the control room

No input data are yet available for assessment of MCR accessibility and habitability in case of severe accident in the spent fuel pool. Such assessment will be subject to further investigation.

6.4.2.6 Conclusion on the adequacy of measures to restrict the radioactive releases

Considering the spent fuel pool structure and its connection with the reactor hall, no possibilities have yet been evaluated to increase the pool reinforcement against severe accident and its isolation from NPP ambient with another barrier.

7 General conclusion

7.1 Key provisions enhancing robustness (already implemented)

Since the beginning of operation the nuclear units in Slovakia have been subject of systematic safety assessment and upgrading in accordance with new Slovak national legislation and international standards. Since EU adhesion, Slovakia also follows Euratom Treaty and derived EU legislation. In general the current legislation reasonably covers the issues relevant for the European stress tests. Currently, all plants in Slovakia are subject to Periodic Safety Reviews (PSRs) with 10 years periodicity. The latest PSR in EBO was completed in 2008, in EMO in 2009. The operational permits are associated with approval of safety upgrading programme of the plants aimed at closer compliance of the safety level with contemporary safety standards. The recently approved programmes include implementation of comprehensive severe accident mitigation measures. Relevant SARs and PSAs Level 1 and 2 updated as appropriate and accepted by the regulatory body are available for all plants. All operating units in Slovakia have been subject to a number of international missions performing independent review of their safety level.

The VVER 440/V213 reactors have a number of inherent safety features favourable for plant recovery from operating events. These features include low core power density, plant layout with six loops isolable by valves on each loop and two turbines reducing severity of many transients, use of horizontal steam generators facilitating transition to natural circulation in the primary circuit, large water inventory in the primary circuit and in steam generators smoothing down disturbances between heat production and heat removal and providing convenient time margins for plant operators. Large amount of coolant available in water trays of the bubbler condenser serves as an additional source of coolant.

In accordance with operator's commitments and instructions received from the regulatory body, the operating organization performed the additional safety assessment (stress tests) on all nuclear units in operation or under construction in Slovakia. Scope of the assessment was in full compliance with the ENSREG specifications.

For determination of safety margins a systematic approach called Configuration Matrix Method was developed. The approach is based on verification of performance of the fundamental safety functions for occurrence of events during operation at power as well as during shutdown modes, taking into account both fuel in the reactor as well as in the spent fuel pools. The method was subsequently adopted by the IAEA as one of the approaches for IAEA independent reviews.

Stress tests offered an opportunity to assess more deeply the safety level of nuclear power plants in Slovakia for potential hazards beyond the legislative requirements. The results confirmed that the plants are in compliance with the original licensing basis and actions have been taken to strengthen their level of protection in order to cope with newly defined threats. Plant design is robust in compliance with principles of defence in depth, including level 4 of defence devoted to prevention and management of severe accidents. There were no such deficiencies identified which would question further safe operation of existing units and continued construction of new units.

In the stress tests additional safety margins were confirmed and additional safety upgrading measures identified, which allow further enhancement of the existing safety level beyond the design basis. None of the measures correspond to an imminent risk requiring prompt actions. The safety margins and safety upgrading measures for different areas of assessment are summarized below.

Earthquakes

There are no tectonic structures located on the territory of the Slovakia and adjacent territories that could cause extremely strong earthquakes comparable to catastrophic earthquake in Japan. Nevertheless, the seismicity is an issue which was seriously considered in design, operation and safety upgrading of the plants and covered by the stress tests. The seismic monitoring system has been implemented and is currently in use around the nuclear sites for early identification of any seismic activity potentially affecting the NPPs.

The assessment of the seismic level of the sites was developed in accordance with IAEA recommendations. It is reflecting the current state of the art and was accepted by several international missions. In subsequent safety upgrading steps, capability of all nuclear units to maintain fundamental safety functions have been strongly increased since the original design. For EBO3,4 the initial design basis with the peak ground acceleration (PGA) $PGA = 0.025 \text{ g}$ has been increased through $PGA 0.25 \text{ g}$ (upgrading performed in 1995) up to the current value $PGA = 0.344 \text{ g}$, with corresponding upgrading completed in 2008. Similarly, in Mochovce the initial site value $PGA = 0.06 \text{ g}$ was increased (based on the IAEA recommendation) to 0.1 g , which was used for the plant construction. Recently using the state of the art method the site seismic level has been raised to 0.143 g . Subsequently the regulatory body has set up the value $PGA = 0.15 \text{ g}$ as a design basis for construction of MO3,4 and for safety upgrading of EMO1,2 units. Since the upgrading was largely based on conservative approach considering mainly elastic behaviour of the structures, there is a margin even above the increased PGA values. Taking into account properties of materials used for individual safety system components, with increasing loads first the occurrence of plastic deformation should take place and only after exceeding the structural limit values the component damage will occur. However, such assessment is beyond the current regulatory requirements and international standards, and the margin was not quantified yet. More refined analyses are in progress in order to define the extra margin embedded in the original conservative design assumptions. The preliminary estimates indicate that safety margins are well beyond the design values. These margins are expected to be quantified by further evaluations.

Flooding

Effects of surface water sources, failure of dams, underground water and extreme meteorological conditions as potential sources of flooding were thoroughly considered. Internal flooding due to rupture of pipelines following the earthquakes was considered in the assessment, too. Due to the inland location of the sites, their distance from the sources of water and the site topography and plant layout conditions, flooding of the site due to the sources of surface water from rivers or lakes can be screened out, similarly as from the ground water. Analysis of potential failures of dams on the rivers Vah and Hron has shown that the induced flooding wave can temporarily disable pumping stations which provide raw water to the plants. These events are conservatively addressed in the stress test report as long-term losses of the ultimate heat sink.

The only meaningful sources of the site flooding are extreme meteorological conditions (strong rain, snow, combination of rain and snow melting). Recently (2011) updated study of extreme meteorological conditions for the Mochovce site was used for the assessment. Flooding of the site due to extreme precipitation is very unlikely; only if extreme precipitation is conservatively combined with blockage of the sewer system and with neglecting any recovery staff actions, up to 10 cm site water level was conservatively estimated for the return period of 10000 years.

Electrical components/systems are the most vulnerable to flooding, depending on their location/elevation in the relevant civil structures. Proper sealing of the buildings and sufficient elevation of the entrance doors provide an adequate protection against flooding. Detailed verification has demonstrated that in both Mochovce

plants large margins (more than 2-times) are already available. In Bohunice, adequate temporary fixing has been implemented and the final permanent protection is in its pre-design stage. In addition, for the situations without any fixing time for flooding safety important components/systems was estimated demonstrating that the time margin to flooding of essential power supply is more than 72 hours. It is important to state that flooding due to precipitation does not occur suddenly and it is not associated with damaging hydrodynamic wave, therefore time margins exist and damaging impact is much less significant.

Extreme meteorological conditions (other than extreme precipitation)

Assessment performed within the stress tests included meteorological events and their combinations, such as extreme temperatures and humidity, extreme drought, ice and snow impact, extreme direct and rotating wind. Feasibility of logistics needed for the emergency preparedness was also evaluated.

Due to location of Slovakia in the mild meteorological region of Europe, extreme conditions were not considered as a major issue in the past, resulting in some cases in limited design information regarding resistance of plant systems, structures and components. Subsequently the evaluations of the effects of extreme meteorological conditions in the stress test report are mostly qualitative (in particular in EBO3,4), based on operating experience and on engineering judgment. Nevertheless, the performed assessment and operational experience has proved that the resistance of the plant against meteorological extremes is acceptable. Extreme drought does not represent serious safety issue since it is a slowly evolving process and the site water inventory is sufficient for more than 10 days of residual heat removal. In addition the upgrading measures implemented with the primary aim to increase seismic resistance contribute also to improved resistance against the wind. Since development of extreme meteorological conditions (except very strong wind) to severe loads on the plant requires certain time, the evaluations also show sufficient time margins for adoption of countermeasures in extreme conditions.

Loss of electric power and loss of ultimate heat sink

Regarding the risk of loss of power supply it may be taken into account that in both sites there are 8 different options (with different vulnerability to external hazards) for providing power supply to plant home consumers (in addition to their redundancies); 5 of these options are independent on the electricity distribution grid. These various options can be activated either automatically or by plant staff within few tens of seconds up to two hours. There are back-up power sources capable to provide power supply for unlimited period of time. The same possibility is offered by connecting the NPPs to the preselected hydro plants. Internal power sources in the plant not dependent on the external grid include 3x100 % redundancy emergency DG with fuel reserves for 9-10 days. A decision on installation of an additional diverse DG dedicated to management of severe accidents has been made as a result of the conducted PSRs already before the Fukushima accident and implementation is currently in progress. In addition mobile DGs for recharging the batteries in case of a long-term SBO and loss of all other AC power sources are being procured. Capacity of batteries was demonstrated to be sufficient for 8-11 hours and further margins exist in optimization of their use and possibility of their recharging from a DG currently being purchased.

Time margins to irreversible losses vary according the operating regimes and success of individual measures. Large number of combinations were analysed and addressed in the stress test report; only some of them are presented below. It was confirmed that there are inherent safety features of VVER 440/V213 contributing to significant time margins in case of loss of electric power and loss of ultimate heat sink, which include the large thermal inertia due to low power and comparably large amount of water both in primary and secondary system,

as well as large volume of water inside the containment stored in the pressure suppression system potentially available for cooling of fuel.

Time margins in case of SBO occurring at full power, using only coolant inventory available in primary and secondary circuit is about 32 hours, using a mobile emergency source would extend the margin to more than 10 days, without any off-site assistance. For shutdown regimes this time interval is extended at least to 2.7 days, and with use of demineralised water emergency tanks up to 13 days. For loss of heat removal from the spent fuel pool, time margins without any operator actions are more than 30 hours for the most conservative case with complete off-loading of the core into the pool, or more than 150 hours for more realistic situations (for partial core unload). These margins can be further extended by about 4-14 hours using coolant from the bubbler condenser trays. Staff interventions by means of the fire trucks would resolve the issue for the unlimited period of time. Containment integrity in case of a complete loss of heat removal will be maintained (without staff actions) for at least 3-5 days.

For NPPs in Slovakia the external atmosphere serves as the primary ultimate heat sink, steam dumping to the atmosphere is an alternate mode of heat removal. Although this UHS in principle cannot be lost, the transport of heat to the UHS can be disabled. Such situations were subject to assessment within the stress tests. If normal plant cooling through the secondary circuit and cooling towers is not available, remaining options include direct release of steam from steam generators to atmosphere through the steam by-pass stations, or by primary circuit feed and bleed, or by heat removal through the essential service water system, the last one being qualified also for emergency conditions. Since failure of all essential service water systems could have serious consequences regarding heat removal from the core, from the spent fuel pool and from the containment, this case was analysed in detail in the stress tests as the most conservative one. If the loss of essential service water is not caused by the station black-out discussed above, loss of raw water supply should be considered. However, large water inventory of cooling water in each unit is sufficient for heat removal for about 8 to 16 days and on-site inventory for about a month. The case of a combined station black-out and loss of ultimate heat sink in case of VVER 440/V213 design is in fact covered by the station black-out only, since the station black-out is always connected with the loss of ultimate heat sink.

Severe accident management

Development and implementation of the accident management programme including mitigation of severe accidents has been an on-going process in all nuclear units in Slovakia independently of the Fukushima accident. Symptom-based emergency operating procedures (EOPs) addressing design basis accidents and preventive part of severe accidents were fully implemented in EBO3,4 and EMO1,2 in 1999 (for events initiated during power operation) and in 2006 (for events initiated in the reactor under shutdown or in the spent fuel pool). Plant specific severe accident management guidelines (SAMG) were prepared for EBO3,4 and EMO1,2 during the period from 2002 to 2004. In 2004-2005, an overall study defining technical specification of modifications and extensions of the VVER 213 basic design needed for implementation of SAMG was prepared. The project of implementation of modifications to support the severe accident management on the basis of SAMG was proposed in compliance with all the requirements and recommendations in Slovak legislation in 2006 - 2007. The SAM implementation project was initiated in 2009 as the common EBO3,4 and EMO1,2 project with deadline in 2013 in EBO and the follow-up implementation in EMO1,2 (implementation accelerated after the Fukushima, with the new deadline 2015).

The measures being implemented include dedicated means for the primary circuit depressurization, hydrogen management using passive autocatalytic recombiners, containment underpressure protection, in-vessel corium retention by strengthening of the reactor cavity and providing for its flooding, dedicated large external tanks

with the boric acid solution with dedicated power source and pump aimed at possible spent fuel flooding, and serving as a supplementary source of coolant for the reactor cavity flooding and for washing out the fission products from the containment atmosphere, modifications enabling coolant make-up to the reactor cavity, spent fuel pool and external source tanks using mobile source connected to the external connection point on walls of the reactor building and auxiliary building, and associated I&C needed for severe accident management. The measures are being implemented for possible use of large amount of coolant from the water trays of the bubbler condenser as an additional source of coolant. Implementation of reliable in vessel molten corium retention prevents complicated ex-vessel phenomena associated with core-concrete interaction, direct containment heating, production of non-condensable gases leading to containment over pressurization, etc.; all these phenomena are associated with large uncertainties.

Large part of the required plant modifications has been already implemented (e.g. installation of autocatalytic recombiners, measures for flooding of the reactor cavity). The long term heat removal from the containment is in the current scope of the SAM project ensured by recovery of service ability of the design basis equipment – the containment spray system.

7.2 Safety issues

The cliff-edge effect is understood as a situation when a small change in a parameter leads to a disproportional sudden increase in consequences. Determination and in particular quantification of the cliff-edges is complicated and sometimes even impossible due to the fact that for the situations beyond the design basis the relevant information was previously not required and therefore is often insufficient. Shortfalls and cliff-edges are discussed below separately for the individual areas of assessment.

Earthquakes

There is a potential for a cliff-edge which can result from the damage of the key structures and equipment needed for the safe shutdown and cooldown of the plant (including availability of the electrical power supply and the ultimate heat sink), or from damage of the access/transport routes to the sites and to the plant structures for the plant staff or external equipment. Not only the plant technological equipment, but also means needed for mitigation of induced effects, such as availability of control rooms for operator actions, fire fighting equipment or means for recovery from internal flooding should be considered.

Based on the assessment the accessibility of the site and the plant is not considered as a major issue due to variety of access roads, convenient time margins and heavy equipment potentially available for debris removal. These provisions also facilitate to address loss of power supply and loss of ultimate heat sink by eventually mobilizing external plant support, as discussed separately in this report.

The key issue is therefore vulnerability of the equipment needed for plant shutdown and cooldown. Such equipment is convincingly available for the earthquakes up to the safe shutdown (design basis) earthquake, as currently specified for individual sites. For the earthquakes beyond the design basis the refined analysis of vulnerability of the key equipment is not available and therefore particular cliff-edges cannot be quantified at this time.

Flooding

No mechanism has been identified in the assessment which would lead to sudden flooding resulting in irreversible loss of safety functions. Certain site flooding is only possible due to unlikely extreme precipitation

combined with complete blockage of the sewer system and neglecting staff actions for release of the blockage. This process would be gradually developing in time thus offering opportunities for recovery.

In Mochovce the existing margins are already so large that all potential cliff-edges can be convincingly screened out. In Bohunice, in the case of combination of flooding and loss of all sources of external power supply and no countermeasure taken, the availability of DGs is vital. The underground situated DGs power outlet could be disabled within 1-2 hours of constant flooding. In case of additional loss of normal source of electrical power this would result in the station blackout scenario. The vulnerability of DG station to flooding can be assumed above about 20 cm of constant level of water around the DG building, which could be identified as a cliff-edge. However, due to temporary measures already taken and in the future after implementation of the fixed protection against flooding this cliff-edge can be screened out too. In additions, operating procedures aimed at operability of the sewage system further supports the robustness of the protection.

Extreme meteorological conditions (other than extreme precipitation)

Loads due to extreme meteorological conditions such as extreme temperatures and humidity, extreme droughts, ice and snow impact would be gradually developing in time, thus providing time margins for taking countermeasures. Strong direct or rotational wind could cause sudden damage. Although for Mochovce NPP sufficient margins were shown, more detailed confirmation is needed regarding the detailed meteorological study and assessment of the impacts using state of the art methods. Precise quantitative specification of the cliff-edges is therefore not available at present.

Loss of electric power and loss of ultimate heat sink

Inherent safety features of V213 design are supported by a number of provisions aimed at prevention of the core damage, which are both providing for convenient time margins for recovery actions. Failures of these hardware provisions or failure of the plant staff to initiate operation of the provisions or rearranging the adequate configurations represent the potential cliff-edges which could result in irreversible core damage. All available options either for loss of power supply or loss of ultimate heat sink, or both are sufficiently described in chapters 1 and 5 of this report; therefore they are not repeated here. Only examples of the failures potentially leading to irreversible core damage are given below:

Failure to provide AC power for home consumption in case of loss of off-site power by all the sources:

- Failure to connect back-up external power supply
- Failure of transition to home consumption operation
- Failure to start all three emergency diesel generators
- In case of successful start of at least one DG, running out internal diesel fuel and failure to refill the fuel tank (in $3 \times 10 \cong 30$ days in sequential use of DGs)
- Failure to connect home consumption to a dedicated hydro plant (Madunice or Gabčíkovo)
- Failure to connect to any of 3 DGs of neighbouring V-1 NPP (for EBO3,4) or to diesel generator station (16x2MWe) in Levice (for Mochovce)
- Failure to connect a diverse DG dedicated for mitigation of severe accidents or running out available fuel in case of successful start-up.

Failure of AC power will take place only if all previous failures occur. Even in this case this is not a cliff-edge, since no sudden loss of safety functions will happen.

Failure to provide DC power from batteries associated with loss of instrumentation:

- Loss of all AC power sources, applicable for recharging the batteries
- Loss of all AC sources followed by exhaustion of capacity of batteries (in ~ 8-11 hours)
- Failure to transport and/or to connect the mobile diesel generator for recharging the batteries
- In case of successful activation of the mobile DG, running out the diesel fuel (inventory to be specified)

All of the above listed options should take place to lead to loss of DC power. Complete loss of DC power would mean a serious situation, because monitoring of plant status would be lost (unless special mobile monitoring equipment would be provided) and control of the plant would be limited to manual control.

Failure to control core reactivity in operating regimes with closed RCS (under condition of loss of AC power):

- Failure to scram the reactor
- Failure to reduce primary pressure in order to inject coolant from the hydroaccumulators
- Failure to connect a small mobile diesel generator for operation of boron pumps

Failure to remove heat from the core in operating regimes with closed RCS (under condition of loss of AC power):

- Failure to operate all steam by-pass stations to atmosphere (to remove heat by secondary coolant boiling – for ~5 hours)
- Failure to activate the fire department to prepare and connect a mobile emergency high pressure feedwater pump (possible for more than 10 days without off-site assistance)
- Loss of feedwater tank or connecting lines, or failure to inject from the feedwater tank to steam generators by gravity (for ~20 hours)
- Failure to open pressurizer relief valve with the objective to reduce primary pressure and allow for coolant injection from hydroaccumulators (for at least 5 hours)
- Failure to replenish on-site stock of cooling water in ~10 days
- Non-availability of a mobile emergency high pressure feedwater pump on both units in case of occurrence of severe accidents at the same time

From the above given broad list, the following human failures during accident management can be considered as the most significant:

- Failure to reconnect DC power to dedicated severe accident power source (available time about 8 hours)
- Failure to connect a small mobile diesel generator for recharging the batteries and operation of boron pumps (available time about 8 hours)
- Failure to activate fire department and connect a mobile emergency high pressure feedwater system before replenishment of coolant in the primary and secondary circuit and to assure adequate water supply (available time about 24 hours)

Severe accident management

It is possible to state that the Emergency Operating Procedures and Severe Accident Management Guidelines provide strategies for mitigation of the accident for all possible scenarios. Operator's failure to perform actions in line with the developed strategies, failure of equipment or unexpected development of the accident differently from considerations in preparation of the strategies (or equipment design) could hypothetically

result in the failure of the containment integrity during the severe accident and become a cliff-edge. Such failures can result not only from the random failures, but also from the severe external hazards beyond the design basis, in particular a major earthquake. Due to variety of the scenarios, it is not possible to describe sequences of actions and time margins available. The following principles and rules are observed in the SAM project and in SAMG with the objective to eliminate possibility of such scenarios:

- Preference is given to dedicated passive equipment or equipment not used prior the severe accident phase of the event, and mostly supplied from the dedicated electric power source;
- All actions important for maintaining containment integrity are in addition to the provisions of the original VVER 440 design supported by additional new design features (highly reliable modifications).

Majority of early (short term) personnel actions included in SAM are included in the procedure CRG-1 that is the only one performed by staff from MCR before ECC activation. Actions in CRG-1 are prepared as algorithm in form of clear instructions and are included in the basic MCR staff training. Therefore the required actions should be performed very reliably.

It should be however taken into account that in accordance with the currently valid requirements the measures have been developed considering occurrence of a severe accident only on one of two units. This limitation should be reconsidered.

7.3 Potential safety improvements and further work forecasted

Based on the results of the safety assessment, the operating organization in spite of the satisfactory level of the plants' safety has identified a number measures for further safety upgrading and enhancing robustness of the plants in the areas covered by the stress tests. Some of the measures are in advanced stage of implementation, some will require longer time. They are summarized below separately for different areas of assessment.

Earthquakes

Robustness of the plant against earthquakes has been significantly increased recently and it is considered to be adequate in accordance with the current requirements. Nevertheless, the following measures for quantification of margins and further improvements are envisaged:

- Quantification of margins of key SSCs for earthquakes beyond the design basis earthquake
- Development of seismic PSA
- Updating plans for logistic arrangement of transport to the NPP following an extreme earthquake.

Flooding

In spite of the extremely low probability of site flooding and measures already available, further provisions are considered to further increase safety level of the plants as follows:

- To finalize a new meteorological study for Bohunice site including recommended extreme values of meteorological parameters to be used for safety assessments and methodology for determination of maximum possible site flooding due to extreme precipitation
- To update the Preoperational Safety Analysis Reports for both EBO3,4 and EMO1,2 for internal and external hazards taking into account updated meteorological data, plant improvements and state of the art methodology
- To update procedures for maintaining operability of rainwater, industrial and sanitary sewer system

- To update procedures for recovery of serviceability of affected plant systems and components following an internal flooding, including activities of operating staff and firemen
- To purchase manual portable submersible pumps with possibility of fire hoses connection
- To purchase powerful portable gasoline / diesel pump
- To install permanent provisions against penetration of water into safety important buildings in the case of flooding in Bohunice site.

Extreme meteorological conditions (other than extreme precipitation)

Major design and construction measures and administrative arrangements, which can be envisaged to increase robustness of the Bohunice and Mochovce plants against extreme weather conditions (i.e. extreme wind, temperatures and humidity, snow amount, freeze and icing, and their combinations), include the following actions:

- To finalize the report of Slovak Hydro-meteorological Institute for Bohunice site to consider recent knowledge on meteorological conditions;
- To update the safety report for Bohunice nuclear power plant and its referenced supportive documents dealing with external threats to be in line with international requirements and recent knowledge of meteorological conditions;
- To perform the detailed assessment of impact of extreme meteorological conditions (temperature and combination of wind/ icing) to the vulnerability of high voltage line at the Bohunice and Mochovce sites.
- To increase the frequency for plant walk-down of diesel generator stations at time of low temperatures, snowing and icing;
- To design and implement preventive measures at ambient temperatures below the design basis to maintain the functionality of equipment relevant to safety and fire extinguishing equipment.

Loss of electric power and loss of ultimate heat sink

As described above, the evaluation of safety margins at station black-out proved the ability to ensure protection of safety barriers during considerably long time, thus providing sufficient time for accident management actions for recovery of the plant power supply. Despite the robustness of the current plant design, the following improvements are still being considered:

- To increase resistance and reliability of AC emergency power supply for beyond design basis accidents by installation of new 6 kV emergency DG for severe accidents,
- To provide 0.4 kV DG for each unit for charging batteries and supplying selected unit consumers during SBO including modifications of the pumps of borated coolant system enabling their use during SBO,
- To provide technical solution and cable pre-preparation in order to facilitate mechanical interconnection of batteries between systems,
- To provide lowering the need for emergency illumination in order to extend life time of batteries (subdivision into sections with the possibility for switching off unnecessary consumers, use of energy saving bulbs),
- To provide monitoring system of capacity of batteries (for EBO 3,4),
- To provide mobile measuring instruments able to use stable measuring sensors without power supply,
- To provide vital power supply for containment drainage valves and hydroaccumulator isolation valves (for EMO),

- To consider possibility to control selected valves without vital power supply by means of small portable motor 3-phase generator 0.4 kV,
- To develop operating procedure for possible use of diesel generators installed in Levice switchyard for SBO event (for EMO),
- To assure long-term serviceability of communication means for MCR operators and shift service staff,

For enhanced resistance of the plant in the case of loss of UHS the following modifications are planned:

- To provide additional mobile high-pressure source of SG feedwater for each site, and to ensure logistics of supplies for the mobile source, with possible use for both EBO and EMO (the same nozzles),
- To establish the logistic system for provision of emergency feedwater to suction of mobile emergency pumps from external pure (potable water) water sources after exhaustion of demineralized water inventory,
- To modify connection of emergency mobile source of coolant to the emergency feedwater system suction and discharge with accessibility from the ground level (in EMO) in order to ensure availability of the source in cases of internal and external floods and fires,
- To construct a fixed line for maintaining the coolant inventory in SFP from a mobile source (fire pumps),
- To consider modifications providing for removal of steam from the SFP to the reactor hall and to the atmosphere in case of coolant boiling,
- To document behaviour of the reactor coolant pump seals at long-term failure of cooling (more than 24 hours) in the UHS loss regime.

Severe accident management

SAM project is being currently implemented in both EBO 3,4 and EMO1,2 based on originally defined scope with assumptions for severe accident management on one of two units. The project completion will be followed by evaluation of possible extension to management of a severe accident on both units. Further SAMG improvement and preparation of additional supporting documents for decision making by SAMG and MCR teams will be adopted based on SAMG validation results at project completion.

Regulatory approach

The available legislation provides for sufficient power and flexibility for the regulatory body to address situations like occurred following the Fukushima accident. In particular, the Atomic Act among other requires to reassess the safety level of nuclear facilities and to take adequate countermeasures after obtaining new significant information about the associated risks. The obligation to perform the relevant assessment and implement the countermeasures is put on the licence holder.

As already explained the regulatory body gradually updates the relevant Slovak nuclear safety legislation in accordance with the progress harmonized under the WENRA framework and IAEA Safety Requirements. The plants are being upgraded towards closer compliance with the new requirements within the Periodic Safety Review processes.

After Fukushima, several meetings have been held between the operator and the regulatory body in order to provide for common understanding of the issues. The regulatory body supports commitments of the operating organization to comprehensive assessment of plant vulnerabilities and margins against external natural hazards as well as implementation of additional measures for further safety enhancement of the plants.

The regulatory body is convinced that the process should not be finished by implementation of several individual actions and requires that new challenges as well as required upgrading will be comprehensively evaluated and reflected in the updated Safety Analysis Reports. This requirement applies in particular to the need of updating the Safety Analysis Reports in the area of site characteristics relevant for external and internal hazards as well as plant vulnerabilities and resistance against such hazards. It is specifically required that the comprehensive assessment of the extreme meteorological conditions will be performed and corresponding parts of the SARs will be updated in order to take into account new meteorological data, on-going plant upgrading measures and state of the art methodology.

In addition to existing studies taking into account limited time frameworks the regulatory body will ask for further systematic and comprehensive assessment of plant resistance to the station blackout and loss of ultimate heat sink taking into account the measures for increasing robustness of the plants. Similarly, adequacy of already available analyses for the progression of severe accidents should be assessed. All the assessment should be followed by the evaluation of adequacy of hardware, procedural and organizational provisions for addressing such situations and corrections implemented, as necessary. In particular, occurrence of severe accidents in parallel at several reactors (up to all of them) in the given site under conditions of severely damaged area infrastructure should be considered. It is recommended to harmonize the approaches with the operators of similar reactor types, taking into account all relevant lessons learned from the stress tests. Completion of such works is preliminary expected in about 3 years. The final scope and schedule should benefit and preferably be harmonized within Europe with the use of the peer review of the stress tests.

Appendix 1

Overview of Slovak legislation relevant for the stress tests

All of the aspects addressed within the scope of stress tests are also covered by the Slovak legislation. The most important Act in the area of peaceful use of nuclear power in the Slovak Republic is Act no. 541/2004 Coll. on Peaceful use of nuclear energy (Atomic Act) and on amendment and alterations of several acts. Further details are stated in regulations issued by the UJD. The following provisions are laid down in the Regulation No. 430/2011 on Nuclear safety requirements.

Earthquake

Section 4 of the regulation defines nuclear safety requirements for nuclear facility siting as following:

- (1) During the siting of a nuclear facility, a geological and seismic loading assessment for the selected site must be conducted, containing
 - a) a probabilistic seismic hazard analysis for the site,
 - b) an assessment of seismic and geological conditions in the area, and the geo-engineering and geotechnical aspects of the proposed site,
 - c) designation of earthquake-related hazard through a seismotectonic assessment of the area using the greatest possible scope of collected information,
 - d) an assessment of the risk due to movement caused by earthquakes, taking into account the seismotectonic nature of the area and site-specific conditions,
 - e) an uncertainty analysis as part of the seismic hazard analysis,
 - f) an assessment of the impact of potential surface shift at a fault on the site,
 - g) a review of the geological, geophysical and seismic characteristics of the region, regardless of state borders and the site's geotechnical characteristics, in accordance with international practice, performed in such a manner that the resultant set of data is homogenous for the entire area or at least permits sufficient determination of the nature of seismotectonic structures relevant for the site and the size of the region that was reviewed, the type of information analysed and the scope and details of the analysis that were specified according to the nature and complexity of seismotectonic conditions.
 - h) proof of the adequacy of the scope and detail of information analysed and research performed to determine danger resulting from seismic movement and shift at a fault.
- (2) Regardless of results of analyses performed pursuant to (1), the minimum level of seismic loading determined at the nuclear facility site must be represented by a standard free-fixed horizontal response spectrum corresponding to peak acceleration equal to 0.1 g.

Nuclear safety requirements for a nuclear facility in the siting phase also involve area characteristics that bar the siting of a nuclear facility in this area, and are listed in Annex No. 2 of the regulation (so called „site exclusion“ criteria). Relevant in this context are the following (paragraph c):

It is excluded to site a nuclear facility at the area that experiences geodynamic and karstic phenomena endangering the stability of rock masses in the area such as landslides, kinetically and seismically active faults,

liquefaction of soils, tectonic activity or other phenomena that can change the area's surface grade past specified technical requirements.

Among the general design requirements for nuclear facilities the following provision related to seismicity is given in A (9):

The design must contain a proposed measure to ensure sufficient safety protection from seismic events, including sufficient justification of input data for earthquake resistance level specification.

External events

For other external events the site exclusion criteria are defined in paragraph a) 3. and i):

It is excluded to site a nuclear facility at the area where during normal or abnormal operation or in the event of an operating incident, except for an accident, it cannot be ensured that in this area protection can be provided from the harmful effects of floods and extreme meteorological effects on nuclear facilities and in the case of a storage facility, if there is a high or hard to predict risk stemming from external events and events caused by human activity, or if the evolution of these activities cannot be reliable predicted for the duration of its designed useful life.

Among the general design requirements for nuclear facilities the following provisions related to external events are given:

H. Preventing the occurrence and progression of equipment failure

The design must ensure suitable preventive and mitigating measures for potential flooding, fire, explosion, fragmentation, pipe swing, influence of media flow or leakage of liquids from damaged systems, assemblies and components or other facilities in a nuclear facility.

The design must take into account the effect of external postulated initiating events that can initiate internal fires or flooding, and can lead to the creation of fragments. These concurrent effects of external and internal events must be included in the design.

J. Protection from external events

- (1) Classified components must be designed so that during natural disasters that can be realistically expected, such as earthquakes, windstorms, flooding, deluge, extreme outdoor temperatures, extreme cooling water temperatures, rain of all forms, moisture, frost, the effects of flora, fauna and so on, or during events caused by human activity outside the nuclear facility or during combinations thereof, it is possible to
 - a) safely shut down the nuclear facility and maintain it in a subcritical state,
 - b) remove residual heat from spent nuclear fuel or radioactive waste,
 - c) maintain leaks of radioactive substances below specified levels.
- (2) Aside from requirements for the physical protection of nuclear facilities and nuclear materials enacted by special legislation, the design must also take into account
 - a) the most serious natural phenomena historically recorded in the area around the site of the nuclear facility and extrapolated taking into account limited accuracy as far as size and time of occurrence are concerned;

- b) a combination of effects of phenomena caused by natural conditions and human activity;
 - c) maximum expected acceleration given for the site's location, based on an assessment of the location's seismic loading performed during the siting of the nuclear facility, specified as seismic level 1 and seismic level 2;
 - d) requirements for earthquake-resistant nuclear facility systems, components and structures or parts thereof that must correspond to their safety function and presumed effects of an earthquake according to specified seismic level 1 and seismic level 2;
 - e) airplane crash.
- (3) The design must include a nuclear facility exclusion zone for protecting the nuclear facility from external phenomena that can be caused by natural conditions or human activity.

Relevant provisions for the loss of electrical power and loss of ultimate heat sink

M. Electrical power systems

- (1) Electrical power systems must be designed so that external and internal electrical distribution failures affect operation as little as possible.
- (2) Systems with an impact on nuclear safety that require continuous uninterrupted power must be powered by batteries.
- (3) Batteries must have sufficient capacity to maintain functionality for at least two hours under all circumstances. Like the systems they power, these sources must be separate and independent.
- (4) Technological systems that are redundant in order to ensure nuclear safety must be powered by at least two independent electrical systems and power supplies. If the number of power supplies is lower than the number of independent technological systems, it must be proven that reliability will not be reduced.
- (5) If a single failure in power systems does not interfere with their functionality, a single failure of an electrical system or power supply is allowed.
- (6) If the availability of some system is necessary to ensure nuclear safety, its electrical system must deliver sufficient power even during a single failure.
- (7) Power supplies and systems must be prepared to deliver needed power in a shorter time than which is needed to start up the equipment they power.
- (8) The design of power supply circuitry for systems important for nuclear safety must allow power supply from emergency sources independent of whether operating power supplies are active, and must ensure that functional testing of emergency power supplies can also be performed during normal operation.

N. Heat transfer

- (1) Facilities that participate in transferring heat released through fission and residual heat must be designed so that they reliably ensure cooling under all conditions.
- (2) Heat transfer systems must be redundant, physically separated, insulated and may be capable of interconnection so that they fulfil their function during normal operation even with a single failure, following shutdown even with a single failure, during design basis accidents and selected beyond design basis accidents, and during loss of power from the external grid.

There are certain requirements laid down for nuclear facilities with nuclear reactors (i.e. for NPPs) only:

C. Nuclear reactor core cooling system

- (2) The system of residual heat removal must be designed so that limiting parameters of fuel elements in a nuclear facility that has been shut down are not exceeded.
- (3) The design must include backup of safety systems for residual heat removal, monitoring coolant leaks and the ability to capture them so that the residual heat removal system works reliable even in the case of a single failure and the loss of external power.
- (5) The design must include a solution for the reliable ultimate heat removal from classified equipment during normal operation, abnormal operation and design basis accidents, and which during selected severe accidents must contribute to the removal of heat. Ultimate heat removal is defined as the transfer of residual heat to the atmosphere or to water, or a combination thereof.
- (6) The reliability of systems contributing to the ultimate heat removal through its transfer, providing power or supplying media to ultimate heat removal systems must be achieved for example through the selection of tested equipment and systems, their backup, variety, physical separation, interconnections and insulation.
- (7) Postulated initiating events caused by natural conditions or human activity must be taken into account during the design of the ultimate heat removal system through the suitable selection of various means of heat transfer and supply systems that deliver media for heat transfer.

J. Electrical power supply system

- (1) The design must have the following sources of power available for systems that are important to nuclear safety:
 - a) operating power from the main generator,
 - b) two various sources of grid power from different high voltage switchyards,
 - c) emergency power from an autonomous source located on the nuclear facility site.
- (2) A design with several units on one site must also ensure that
 - a) each unit will have its own source of emergency power,
 - b) each unit will have its own connection to the electrical grid for outward transmission of power that is functionally separated from the others, with all mutual connections being eliminated,
 - c) if a common backup power connection is used, its output must be sufficient for the parallel start-up of all units.

Accident management

D. Containment building system

- (1) A nuclear facility must be equipped with a containment building system that, when postulated initiating

events related to the leak of radioactive substances and ionizing radiation into the environment occur, limit these leaks so that they are lower than established limit leak values, if this function is not provided for by other means.

- (2) The containment building must be designed so that its required degree of tightness is maintained even during design basis accidents. Aside from this, the ability to reduce the consequences of selected severe accidents and to limit the escape of radioactive substances into the environment must be taken into account.
- (3) Pressurized parts of the containment system must be designed with sufficient margins for the highest pressures, under pressures and the highest temperatures that can occur during design basis accidents.
- (4) The containment system must consist of a full-pressure enclosure or an enclosure equipped with a pressure and temperature reduction system, of sealing facilities and ventilation and filtration systems that are dimensioned for all postulated initiating events and that must ensure that permitted parameters are not exceeded even during design basis accidents.
- (5) Facilities inside the containment building must be designed so that they fulfil their function and so that their effect on other systems, assemblies and components is limited.
- (6) Insulation materials, sheathing and coatings of systems, assemblies and components inside the containment building must be designed so that their fulfilment of their safety functions is ensured and so that they resist the effects of their environment even during design basis accidents.
- (7) The containment building and systems, assemblies and components important for it to maintain its tightness must be designed so that it is possible to
 - a) perform leak tests at design pressure after
 1. the installation of all bushings and penetrations,
 2. realized repairs;
 - b) prior to commissioning, prove its integrity through a pressure test using a test pressure higher than design pressure;
 - c) during normal operation of the nuclear facility,
 1. perform regular inspections of individual assemblies and components of the containment building;
 2. perform functional tests of individual containment building systems, assemblies and components;
 3. perform regular leak tests of the containment building at design pressure or at lower pressures that permit extrapolation;
 4. prevent a reduction of its containment ability by flying fragments or pipe whipping.
- (8) Bushings passing through the walls of the containment building must be designed so that
 - a) leak tests can be performed,
 - b) regular tests of their seals can be performed at design pressure independent of leak tests of the hermetic sheath,
 - c) they are protected from the effects of dynamic forces,
 - d) their number is as low as possible,

- e) they all meet the same design requirements as the containment building itself.
- (9) Primary circuit pipes that pass through the walls of the containment building, or pipes that are directly connected to the containment building's atmosphere must be equipped with reliable automatic isolation mechanisms, each of which having at least two isolating elements in series that are located outside and inside the containment building and are controlled independently and reliably. The outside isolating elements must be located as close as possible to the containment building.
- (10) Other pipes passing through the walls of the containment building must have at least one outside isolating element located as close as possible to the containment building.
- (11) Isolating elements must be designed so that they
- a) can be regularly tested for leaks,
 - b) perform their function even during a single failure, aside from their mechanical part.
- (12) Service openings in the walls of the containment building must be equipped with double doors operated separately so that tightness is always ensured. The tightness of service openings must correspond to the tightness of the containment building system.
- (13) Flow paths between parts of the space inside the containment building must be designed so that pressure differences occurring during operating events do not damage the containment building or other containment building system facilities.
- (14) If a heat removal system is used to transfer heat out of the containment building, it must be designed to ensure its reliability and functional redundancy during a single failure.
- (15) The containment building must be equipped with systems for the detection of hydrogen and radioactive substances that could leak into it during and following postulated initiating events. Along with other systems, these systems must
- a) reduce activity concentration and modify fission product composition,
 - b) monitor and maintain hydrogen concentrations at permitted levels in order to ensure containment building integrity.
- (16) A containment building equipped with a pressure and temperature reduction system must have important support systems, assemblies and components backed up to ensure their functionality even during a single failure.
- (17) It must be possible to isolate the containment building during beyond design accidents. If the incident leads to a bypass of the containment building, its consequences must be mitigated.
- (18) The tightness of the containment building must not be reduced significantly for a reasonable time following a severe accident.
- (19) The pressure and temperature inside the containment building must be controlled during a severe accident.
- (20) The concentration of flammable gases must be controlled during a severe accident.
- (21) The containment building must be protected from internal overpressure during a severe accident.
- (22) Reactor core meltdown scenario at high pressures must be prevented.
- (23) Damage to the containment building by molten fuel must be prevented to a reasonably achievable extent.

E. Safety analyses and severe accidents

- (1) The design must include analyses of the responses of the nuclear facility at least to the following postulated initiating events:
- a) small, medium and large leaks of primary circuit coolant (LOCA) in the main circulation piping,
 - b) a break of the main steam piping and feed water piping,
 - c) reduced coolant flow through the reactor,
 - d) increased or reduced feed water flow,
 - e) increased or reduced steam flow,
 - f) unexpected opening of pressure release valves of the pressurizer,
 - g) unexpected start-up of the emergency core cooling system,
 - h) unexpected opening of steam generator safety valves,
 - i) unexpected closing of main isolation valves on main steam piping,
 - j) steam generator tubes rupture,
 - k) uncontrolled movement of control rods,
 - l) ejection of control rods,
 - m) loss of external power supply,
 - n) an accident during fuel handling,
 - o) a failure of normal primary circuit makeup system,
 - p) coolant leaks from the primary circuit to intermediate circuits outside the hermetic zones,
 - q) a heat removal failure during natural circulation cooling mode,
 - r) a spent fuel storage pool cooling failure,
 - s) the fall of a load due to failure of lifting equipment,
 - t) fires, explosions and flooding.
- (2) The design must include response analyses for the proposed facility for at least the following postulated external initiating events:
- a) unfavourable natural conditions, including
 1. extreme wind load,
 2. extreme outdoor temperatures,
 3. extreme rain and local flooding,
 4. extreme cooling water temperatures and icing,
 5. earthquakes.
 - b) aircraft crash,

c) the effect of human activity and industrial activity near the nuclear facility.

(3) The design must include analyses of the following beyond design basis accident scenarios:

- a) occurrence of abnormal operation with failure of automatic reactor scram,
- b) complete loss of power for own consumption (station black-out),
- c) complete loss of feed water,
- d) a primary coolant leak with failure of emergency core cooling system,
- e) loss of coolant in the reactor in natural circulation cooling mode,
- f) complete loss of essential service water,
- g) loss of heat removal from the core for a reactor that has been shut down,
- h) uncontrolled dilution of boric acid in the reactor,
- i) rupture of several steam generator heat exchanger tubes,
- j) rupture of main steam pipe along with the simultaneous rupture of a steam generator heat exchanger tube,
- k) loss of safety systems needed during the long-term phase following a postulated initiating event,
- l) loss of spent fuel storage pool cooling.

(4) Analyses performed pursuant to the previous subsection may be performed by a realistic approach while using modified acceptance criteria.

(5) Based on operating experience, relevant safety analyses and the results of research, the design must also focus on selected severe accidents, while taking into account

- a) the possibility of multiple failures of safety systems with a subsequent threat to the integrity of physical barriers preventing the escape of radioactive substances; preventive or mitigating measures need not include the application of a conservative approach to ensuring nuclear safety;
- b) a set of selected events that are identified from among postulated initiating events using a combination of probabilistic methods, deterministic methods and technical evaluation, and that have been subsequently reviewed using a set of criteria in order to determine which severe accidents the design will address;
- c) assessment and implementation of any design changes, changes to documentation or operating procedures that could reduce the likelihood of the occurrence of events selected pursuant to (b) or mitigate their consequences, if their implementation is reasonably possible;
- d) the ability to utilize some safety systems as well as systems not directly related to nuclear safety, or additional temporary systems for the accomplishment of functions other than those originally planned, and under operating conditions other than originally expected, for putting the nuclear facility into a controlled state or to mitigate the consequences of selected events pursuant to (b);
- e) content of operating procedures for the management of accidents during their occurrence;
- f) for multi-unit nuclear facilities with a nuclear reactor, the use of available support measures from other units, as long as these units' safe operation is not threatened.

- (6) Analyses of design basis accidents must take into account the uncertainty of parameters used to ensure that analysis results are conservative.
- (7) To preserve a conservative approach, design basis accident analyses may consider only activity of safety systems. The activity of systems that are not classified as safety systems can only be taken into account if they have a negative effect on an initiating event.
- (8) In design basis accident analyses a stuck control rod shall be considered as an additional aggravating failure in the analysis of design basis events for all postulated initiating events.
- (9) The design must include analyses that verify the behaviour of nuclear facilities during specific beyond design basis accidents, including severe accidents, so that in cases of events with a very low probability of occurrence leakage of radioactive substances harmful to the population and the environment is minimized as far as reasonably achievable.

Appendix 2.

Compliance of containment of VVER 440/V213 units in Slovakia with relevant international requirements

1. Compliance of upgraded VVER 440/V213 containment with the relevant IAEA safety requirements (reference document: "Safety of Nuclear Power Plants: Design", NS-R-1, 2000)		
IAEA req.	Description of the requirement	Relevant design measures implemented
Design of the containment system	<p>A containment system shall be provided in order to ensure that any release of radioactive materials to the environment in case of a design-basis accident (i.e. an accident against which the plant is designed) would be below prescribed limits.</p> <p>In addition, consideration shall be given to the provision of features for the mitigation of the consequences of severe accidents (i.e. very unlikely accidents involving significant core degradation), in order to limit the release of radioactive material to the environment.</p>	<p>MO3,4 containment is a leak-tight building made of robust concrete walls. The containment is equipped with a passive pressure suppression system (bubbler condenser), which allows to quickly reach sub-atmospheric containment pressure (with subsequent termination of releases) in case of design-basis accidents with loss of coolant.</p> <p>The great relevance given by IAEA to the mitigative capabilities of the NPP in case of a severe accident is evident in all the requirements that follow. This shows that the preservation of containment integrity even in the case of a severe accident is a primary concern for nuclear safety. For this reason, following the IAEA guidance, the Mochovce 3-4 containment design has been recently improved by adding dedicated measures for coping with such scenarios.</p> <p>For all the accidents considered in the design, it has been demonstrated that the radiological consequences to the environment are below internationally recognized limits.</p>

1. Compliance of upgraded VVER 440/V213 containment with the relevant IAEA safety requirements (reference document: "Safety of Nuclear Power Plants: Design", NS-R-1, 2000)		
IAEA req.	Description of the requirement	Relevant design measures implemented
Strength of the containment structure	<p>The strength of the containment structure shall be calculated with adequate margins.</p> <p>In calculating the necessary strength of the containment structure, natural phenomena and human induced events shall be taken into consideration.</p> <p>Provisions for maintaining containment integrity in case of a severe accident shall be considered. In particular, the effects of any predicted combustion of flammable gases (typically, hydrogen) shall be taken into account.</p>	<p>With the safety improvements considered during the revision of the Basic Design, the Mochovce 3-4 containment design shows adequate design margins for both design-basis accidents (DBA) and severe accidents (SA). In particular, the resistance against severe accidents has been achieved through the safety improvements identified during the revision of the Basic Design. All the relevant design-basis accidents, including full rupture of the largest pipes of the reactor coolant system, have been taken into account in the containment design.</p> <p>External events (natural or man-made) have been identified on the basis of deterministic requirements and also on the basis of a probabilistic analyses, in accordance with international standards (IAEA, WENRA) and the national legislation valid in the Slovak Republic. All the external events for the containment design have been taken into account and translated into containment design conditions according to IAEA Safety Standards.</p> <p>The containment integrity during and after a severe accident is ensured by a set of dedicated design features which includes depressurization of reactor coolant system, coolability of degraded core inside the reactor vessel, management of flammable gases (above all hydrogen) by means of passive recombiners and igniters, containment pressure control and fission products removal by means of a dedicated spray system.</p>

1. Compliance of upgraded VVER 440/V213 containment with the relevant IAEA safety requirements (reference document: "Safety of Nuclear Power Plants: Design", NS-R-1, 2000)		
IAEA req.	Description of the requirement	Relevant design measures implemented
Capability for containment pressure tests	It shall be possible to perform pressure tests to demonstrate the containment structural integrity before operation of the plant and over the plant's lifetime.	Pressure tests of the containment for the demonstration of its structural integrity have been established. These include tests of containment boundary components as well as full design pressure test of the containment, to be carried out during the commissioning (i.e. before operation of the plant) and after each plant outage.
Containment leakage	<p>The containment system shall be designed so that the prescribed maximum leakage rate is not exceeded during an accident.</p> <p>The primary containment may be partially or totally surrounded by a secondary containment for the collection and controlled release of materials that may leak from the primary containment during an accident (including a severe accident).</p> <p>Determination of the leakage rate of the containment system at periodic intervals over the service lifetime of the reactor shall be possible.</p> <p>The capability to control any leakage of radioactive materials from the containment during a severe accident shall be adequately considered.</p>	<p>The maximum leakage rate of the containment is strictly specified by the design and regularly tested before and during the plant operational life. Because of specific design features (e.g. fast transition to containment underpressure after an accident) and of the design improvements recently implemented, the Mochovce containment complies with the current radiological limits internationally adopted (also taking into account severe accidents scenarios).</p> <p>For this reason, the distinction between the concept of "full containment" (i.e. a containment fully able to carry out all its intended safety functions) and of "double containment" – consisting of a primary containment and a secondary containment – has to be remarked. The IAEA safety requirements introduce a secondary containment as an option for the collection of potential leakages from the primary containment, but do not strictly require its implementation. For this reason, the "secondary containment" has not to be regarded as a "second containment", i.e. as a replica of the first containment with the same functions.</p> <p>The secondary containment is not required by IAEA as nothing prevents a single containment from providing all the necessary protection from internal as well as from external events.</p> <p>The periodic pressure tests mentioned above are also aimed at determining the leakage rate of the containment.</p> <p>Several design measures recently defined for Mochovce 3-4 have been conceived with the primary goal of preserving the containment integrity in case of a severe accident, to strongly limit the radioactive releases from containment also in such an unlikely scenario.</p>

1. Compliance of upgraded VVER 440/V213 containment with the relevant IAEA safety requirements (reference document: "Safety of Nuclear Power Plants: Design", NS-R-1, 2000)		
IAEA req.	Description of the requirement	Relevant design measures implemented
Containment penetrations	In order to ensure a higher containment tightness in normal, accident and severe accident conditions, the number of penetrations through the containment shall be kept to a practical minimum and shall meet the same design requirements as the containment structure itself.	The number of containment penetrations is determined by the technological needs (i.e. number and layout of pipelines and cables penetrating the containment wall). The design requirements for the penetrations are the same as for the containment structure itself and they have been prescribed considering severe accident conditions. The tightness of the penetrations is verified during containment tightness tests.
Containment isolation	In order to increase the containment resistance against the release of radioactive material in case of an accident, proper equipment shall be installed so that, in emergency conditions, the containment can be automatically and reliably isolated.	The containment is provided with an automatic isolation system. During normal operation, the containment is kept at sub-atmospheric pressure and no unfiltered releases are sent to the environment. Whenever the pressure in the containment increases, due to an accident, by more than 10 kPa, all the lines that penetrate the containment are automatically and reliably closed, to isolate the containment from the environment.
Containment air locks	Access by personnel to the containment shall be through properly equipped doors, in order to ensure that at least one door is closed during reactor operations and during an accident.	The containment is equipped with a double door for personnel access (personnel air lock). The doors are reliably sealed and interlocked to ensure tightness of containment during reactor operation and accident.
Internal structures of containment	In order to ensure the full capability of the containment to withstand an accident (including a severe accident), adequate consideration shall also be given to the capability of the internal structures of the containment to withstand the effects of such accident.	The capability of the internal structures of the containment to withstand with sufficient margins the effects of an accident has been demonstrated in the design and safety documentation of the plant. In addition, the strength of the most important internal structures of the containment (i.e. the pressure suppression system) has been verified experimentally in an international project (PHARE 2.13/95).
Removal of heat from the containment	It shall be possible to remove heat from the reactor containment (in order to limit the containment internal pressure and hence reduce the containment structural loads) in normal and emergency conditions, including severe accidents.	The containment thermal capacity, due to its robust concrete wall, is very high and allows for large heat absorption. The limitation of the internal pressure is provided passively by the pressure suppression system. Long-term heat removal is ensured by redundant trains of the fast acting active spray systems. In addition, there is a dedicated pump and an extra water source to preserve the integrity of the containment during a severe accident.

1. Compliance of upgraded VVER 440/V213 containment with the relevant IAEA safety requirements (reference document: "Safety of Nuclear Power Plants: Design", NS-R-1, 2000)		
IAEA req.	Description of the requirement	Relevant design measures implemented
Control and cleanup of the containment atmosphere	As a further measure for containment protection, it shall be possible to control the radioactive and/or flammable gases (above all, hydrogen) which may be released into the containment during an accident (including a severe accident). This is required in order to: reduce the amount of releases to the environment during an accident; prevent the deflagration or detonation of gases such as hydrogen, which could jeopardize the integrity of the containment.	Prevention of hydrogen deflagration or detonation is ensured by means of passive autocatalytic hydrogen igniters and recombiners, with capability to cope also with severe accidents. The removal of fission products from the containment atmosphere is provided by the wash-out effect of the active containment spray system. In addition, there is a dedicated pump and an extra source of water which further enhance the cleanup of containment atmosphere during a severe accident.
Coverings and coatings	The coverings and coatings for components and structures within the containment (e.g. thermal insulation of piping) shall be carefully selected to minimize the impact on safety of their possible deterioration.	The containment walls are covered by stainless steel resistant against deterioration. The potential impact on safety of the insulation of the piping inside the containment has been experimentally investigated in an international project (PHARE 2.05/95), and proper design countermeasures have been implemented in the Mochovce design.
<p>Conclusion: <u>All the IAEA requirements</u> on containment are met at the upgraded VVER 440/V213 containment performance during DBA</p>		

2. Compliance of upgraded VVER 440/V213 containment with the relevant WENRA safety requirements (reference document: "WENRA Reactor Safety Reference Levels", January 2008)

WENRA req.	Description of the requirement	Relevant design measures implemented
Containment functions	<p>A containment system shall be provided in order to ensure that any release of radioactive material to the environment in a design basis accident would be below prescribed limits. This system shall include:</p> <ul style="list-style-type: none"> – leak-tight structures covering all essential parts of the primary system; – associated systems for control of pressures and temperatures; – features for isolation. 	<p>Containment is a leak-tight building made of robust concrete walls. It is provided with all the features required for the effective control of pressures and temperatures in all the plant design basis conditions (including severe accidents), and for its reliable and automatic isolation in case of an accident.</p>
	<p>Each line that penetrates the containment as part of the reactor coolant pressure boundary or that is connected directly to the containment atmosphere shall be automatically and reliably sealable in the event of a design basis accident. These lines shall be fitted with at least two containment isolation valves arranged in series. Isolation valves shall be located as close to the containment as is practicable.</p>	<p>The containment is provided with an automatic isolation system. During normal operation, the containment is kept at sub-atmospheric pressure and no unfiltered releases are sent to the environment. Whenever the pressure in the containment increases, due to an accident, by more than 10 kPa, all the lines that penetrate the containment are sealed following the WENRA design requirements under discussion here, in order to isolate the containment from the environment.</p>
	<p>Each line that penetrates the containment and is neither part of the reactor coolant pressure boundary nor connected directly to the containment atmosphere shall have at least one containment isolation valve. This valve shall be outside the containment and located as close to the containment as practicable.</p>	<p>See comment above.</p>

2. Compliance of upgraded VVER 440/V213 containment with the relevant WENRA safety requirements (reference document: "WENRA Reactor Safety Reference Levels", January 2008)

Protection of the containment against selected beyond design basis accidents	Isolation of the containment shall be possible in a beyond design basis accident.	In addition to the measures conceived for design-basis accidents (which are discussed in the following), additional measures have been defined specifically for the proper management of beyond-design-basis scenarios, i.e.: <ul style="list-style-type: none"> – improvement of the tightness of the penetrations leading into the reactor cavity; – improvement of the tightness of the access door to the reactor cavity; – improvement of the drain line from the reactor cavity.
	The leaktightness of the containment shall not degrade significantly for a reasonable time after a severe accident. However, if an event leads to bypass of the containment, consequences shall be mitigated.	Main relevant measures: <ul style="list-style-type: none"> – installation of a dedicated system aimed at avoiding an excessive underpressure inside the containment, which could cause a loss of integrity and hence of leaktightness; – inclusion in the design of an additional, independent, dedicated system for the delivery of coolant from an additional, stand-by source into the containment in a severe-accident scenario (to avoid excessive containment overpressures which could cause a loss of containment integrity); – inclusion in the design of a system for the controlled depressurization of the reactor coolant system, thus avoiding damages to containment induced by a high-pressure severe accident scenario (see also the next WENRA requirement).
	High pressure core melt scenarios shall be prevented.	Relevant safety measure: inclusion in the design of a system for the controlled depressurization of the reactor coolant system, thus avoiding damages to containment induced by a high-pressure severe accident scenario.
	Combustible gases shall be managed in a severe accident.	Relevant measure: Installation of recombiners and igniters qualified for severe accident conditions, in order to avoid in-containment uncontrolled burning of burnable gases.

2. Compliance of upgraded VVER 440/V213 containment with the relevant WENRA safety requirements (reference document: "WENRA Reactor Safety Reference Levels", January 2008)

Protection of the containment against selected beyond design basis accidents	Containment degradation by molten fuel shall be prevented or mitigated as far as reasonably practicable.	<p>The relevant measures include all the provisions required for successful implementation of the in-vessel core retention strategy, i.e.:</p> <ul style="list-style-type: none"> – modification of the penetrations leading to the reactor cavity; – modification of the access cavity door; – modification of the drain line from the reactor cavity; – provision of sufficient coolant inventory for cavity flooding (draining system of the bubbler tower trays); – modification of thermal shielding of the bottom of the reactor pressure vessel to allow its external flooding; – creation of a circulation channel for coolant along the reactor pressure vessel wall; – installation of a dedicated diesel generator for severe-accident scenarios; – addition of external, independent sources of coolant for severe-accident scenarios.
	Pressure and temperature in the containment shall be managed in a severe accident.	<p>Relevant measures:</p> <ul style="list-style-type: none"> – installation of a system aimed at avoiding an excessive underpressure inside the containment; – combined use of the existing containment spray system and of a dedicated spray system relying on an additional source of coolant, to avoid containment overpressure; – installation of recombiners and igniters qualified for severe accident conditions, in order to avoid in-containment uncontrolled burning of burnable gases; – installation of an additional diesel-generator dedicated for severe accident scenarios.
	The containment shall be protected from overpressure in a severe accident.	See point above.

Conclusion:

The upgraded VVER 440/V213 containment is in full compliance with the WENRA Reference Levels.